

OVERVIEW

The SM8706B is a clock generator IC that generates 3 clocks with 6 outputs from a 36.8640MHz master clock for application in DVD players. The SM8706B has 2 built-in PLL circuits that together with a crystal oscillator can generate the 384fs and 768fs audio system clocks, 27MHz and 54MHz video system clocks, and 16.9344MHz and 33.8688MHz signal processor system clocks required for a DVD player. The SM8706B also supports the 44.1kHz and 48kHz sampling frequencies, and the sampling frequency can be switched while the device is operating.

FEATURES

- 36.8640MHz master clock (internal PLL reference clock)
- Generated clocks
 - Video system output: 27MHz, 54MHz
 - Audio system output: 384fs, 768fs
 - Signal processor system output: 16.9344MHz, 33.8688MHz
- Supported sampling frequency fs: 44.1/48kHz
- Low jitter output: 40ps typ. (1-sigma, 25pF load)
- Supply voltage: 3.3V ± 0.3V
- 16-pin VSOP package

APPLICATIONS

- DVD players
- DVD car navigation system

ORDERING INFORMATION

Device	Package
SM8706BV	16-pin VSOP

PINOUT

(Top view)

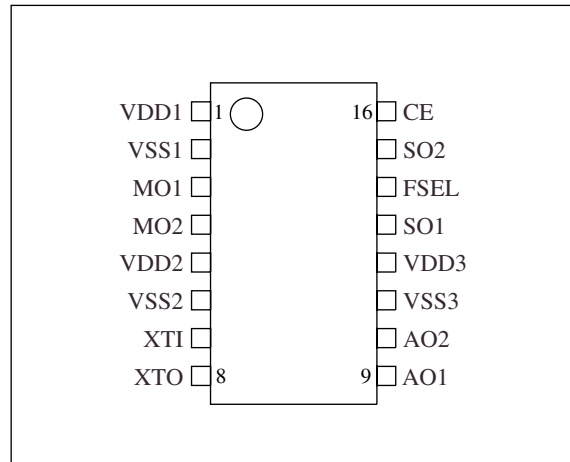

PACKAGE DIMENSIONS

(Unit: mm)
Weight: 0.07g

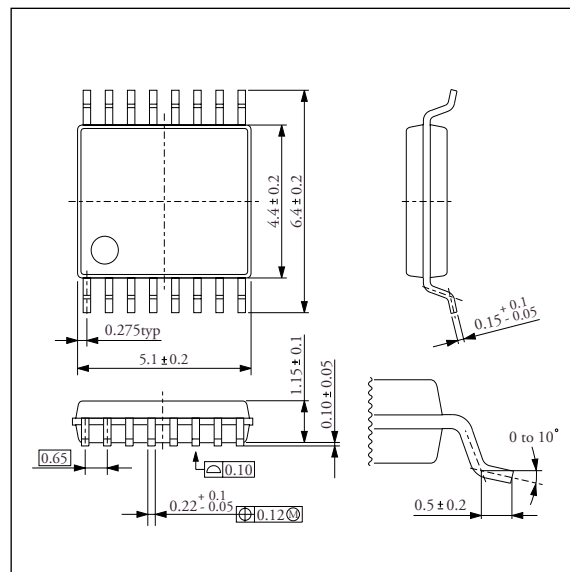

BLOCK DIAGRAM

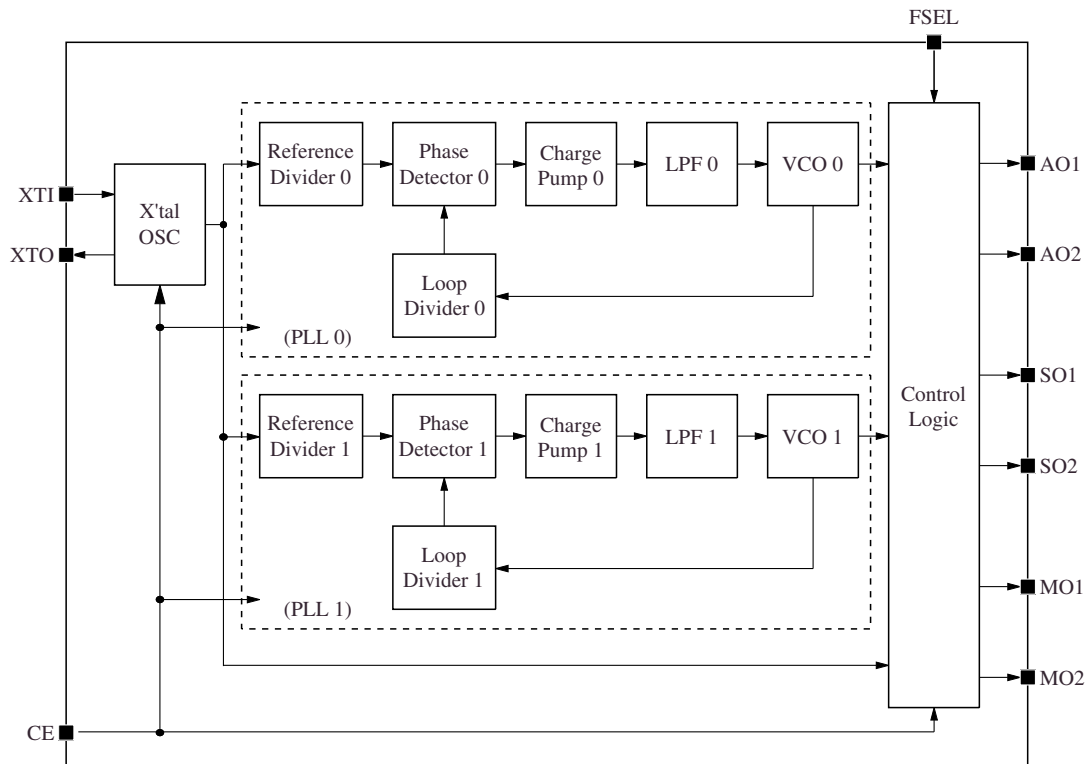

PIN DESCRIPTION

Number	Name	I/O	Description
1	VDD1	-	Supply 1 for digital block
2	VSS1	-	Ground 1 for digital block
3	MO1	O	Video system output 1 (27MHz fixed)
4	MO2	O	Video system output 2 (54MHz fixed)
5	VDD2	-	Supply 2 for analog block
6	VSS2	-	Ground 2 for analog block
7	XTI	I	Crystal oscillator connection or external clock input
8	XTO	O	Crystal oscillator connection
9	AO1	O	Audio system output 1 (384fs output)
10	AO2	O	Audio system output 2 (768fs output)
11	VSS3	-	Ground 3 for digital block
12	VDD3	-	Supply 3 for digital block
13	SO1	O	Signal processor system output 1 (16.9344MHz fixed)
14	FSEL	I	Sampling frequency select FSEL = HIGH: fs = 48kHz FSEL = LOW: fs = 44.1kHz (with internal pull-up resistor, Schmitt-trigger input)
15	SO2	O	Signal processor system output 2 (33.8688MHz fixed)
16	CE	I	Chip enable (HIGH = Enable, LOW = Disable)

SM8706B

Note: Unless otherwise noted, VDD applies to VDD1, VDD2, and VDD3. Similarly, VSS applies to VSS1, VSS2, and VSS3.

SPECIFICATIONS

Absolute Maximum Ratings

Parameter	Symbol	Condition	Rating	Unit
Supply voltage range	$V_{DD1}, V_{DD2}, V_{DD3}$		- 0.3 to + 6.5	V
Supply voltage deviation	$V_{DD1} - V_{DD2},$ $V_{DD1} - V_{DD3},$ $V_{DD2} - V_{DD3}$		± 0.1	V
Input voltage range	V_{IN}		- 0.3 to $V_{DD} + 0.3$	V
Output voltage range	V_{OUT}		- 0.3 to $V_{DD} + 0.3$	V
Power dissipation	P_D		165	mW
Storage temperature range	T_{stg}		- 55 to + 125	°C

Recommended Operating Conditions

$V_{SS} = V_{SS1} = V_{SS2} = V_{SS3} = 0V$ unless otherwise noted.

Parameter	Symbol	Condition	Rating			Unit
			min	typ	max	
Supply voltage ranges ^{1, 2, 3}	$V_{DD1}, V_{DD2}, V_{DD3}$		+ 3.0	-	+ 3.6	V
Output load capacitance 1	C_{L1}	MO1, SO1, SO2 outputs	-	-	25	pF
Output load capacitance 2	C_{L2}	All outputs excluding MO1, SO1, SO2, XTO	-	-	15	pF
Master clock frequency	f_{XTAL}	When using crystal oscillator	-	36.8640	-	MHz
Operating temperature range	T_{opr}		- 40	-	+ 85	°C

- The supply voltage is defined relative to $V_{SS} = 0V$
- The supply voltages applied on VDD1, VDD2, and VDD3 should be derived from a common supply source.
- If the supply voltages on VDD1, VDD2, and VDD3 are from different sources, they should be applied simultaneously. The SM8706B may be damaged if the supply voltage timing is different.

DC Electrical Characteristics

$f_{XTAL} = 36.8640MHz$, $V_{DD} = 3.3V \pm 0.3V$, $V_{SS} = 0V$, $T_a = - 40$ to $+ 85$ °C unless otherwise noted.

Parameter	Symbol	Condition	Rating			Unit
			min	typ	max	
Current consumption	I_{DD}	$V_{DD} = 3.3V$, $T_a = 25^\circ C$, $f_s = 48kHz$, Crystal oscillator, no load on all outputs	-	35	45	mA
HIGH-level input voltage	V_{IH}	FSEL, CE, XT1, $V_{DD} = 3.3V$	$0.8 V_{DD}$	-	-	V
LOW-level input voltage	V_{IL}		-	-	$0.2 V_{DD}$	V
HIGH-level input current ¹	I_{IH1}	FSEL, CE, $V_{IN} = V_{DD}$	-	-	1	μA
LOW-level input current ¹	I_{IL1}	FSEL, CE, $V_{IN} = 0V$	- 100	-	-	μA
HIGH-level input current	I_{IH2}	XT1, $V_{IN} = V_{DD}$	-	-	40	μA
LOW-level input current	I_{IL2}	XT1, $V_{IN} = 0V$	- 40	-	-	μA
HIGH-level output voltage	V_{OH}	All outputs excluding XTO, $I_{OH} = - 2mA$	$V_{DD} - 0.4$	-	-	V
LOW-level output voltage	V_{OL}	All outputs excluding XTO, $I_{OL} = 2mA$	-	-	0.4	V

- FSEL and CE pins have Schmitt-trigger input and built-in pull-up resistor.

AC Electrical Characteristics

$f_{XTAL} = 36.8640\text{MHz}$, $V_{DD} = 3.3\text{V} \pm 0.3\text{V}$, $V_{SS} = 0\text{V}$, $T_a = -40$ to $+85\text{ }^\circ\text{C}$ unless otherwise noted.

Parameter	Symbol	Condition	Rating			Unit
			min	typ	max	
External input clock frequency ¹	f_{XTI}	XTI, applies to external clock input use only	–	36.8640	–	MHz
Output clock rise time ²	t_r	MO1, SO1, SO2, $C_L = 25\text{ pF}$, transition between $V_{OL} = 0.2V_{DD}$ and $V_{OH} = 0.8V_{DD}$	–	2.0	–	ns
		Outputs excluding MO1, SO1, SO2, and XTO, $C_L = 15\text{ pF}$, transition between $V_{OL} = 0.2V_{DD}$ and $V_{OH} = 0.8V_{DD}$	–	2.0	–	
Output clock fall time ²	t_f	MO1, SO1, SO2, $C_L = 25\text{ pF}$, transition between $V_{OH} = 0.8V_{DD}$ and $V_{OL} = 0.2V_{DD}$	–	2.0	–	ns
		Outputs excluding MO1, SO1, SO2, and XTO, $C_L = 15\text{ pF}$, transition between $V_{OH} = 0.8V_{DD}$ and $V_{OL} = 0.2V_{DD}$	–	2.0	–	
Output clock jitter ³	t_{jitter} (1-sigma)	MO1, SO1, SO2, $T_a = 25^\circ\text{C}$, $C_L = 25\text{ pF}$, $V_O = 0.5V_{DD}$	–	40	–	ps
		Outputs excluding MO1, SO1, SO2, and XTO, $T_a = 25^\circ\text{C}$, $C_L = 15\text{ pF}$, $V_O = 0.5V_{DD}$	–	40	–	
Output clock duty cycle ²	Dt	MO1, SO1, SO2, $T_a = 25^\circ\text{C}$, $C_L = 25\text{ pF}$, $V_O = 0.5V_{DD}$	45	50	55	%
		Outputs excluding MO1, SO1, SO2, and XTO, $T_a = 25^\circ\text{C}$, $C_L = 15\text{ pF}$, $V_O = 0.5V_{DD}$	45	50	55	
Settling time ²	t_s	All outputs excluding XTO	–	–	1	μs
Power-up time ^{2,4}	t_p	All outputs excluding XTO	–	1	5	ms

1. When using an external clock input, the XTI duty should be 50% with 3.3V clock signal amplitude level. The input signal voltage should not exceed the absolute maximum rating, otherwise damage may occur.
2. The numeric values are measured values using the circuit in Figure 1 and the NPC standard evaluation board.
3. The numeric values are measured values obtained using the circuit in Figure 2 and the NPC standard evaluation board.
4. This is the time, after the supply is turned ON from the OFF state, until the output clock reaches $\pm 0.1\%$ of the specified frequency.

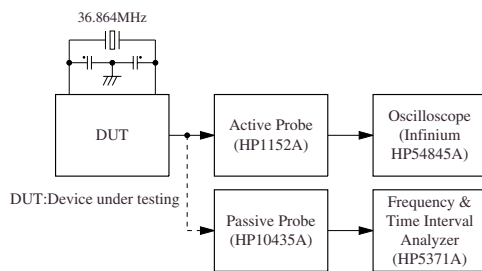

Figure 1. Measurement circuit 1

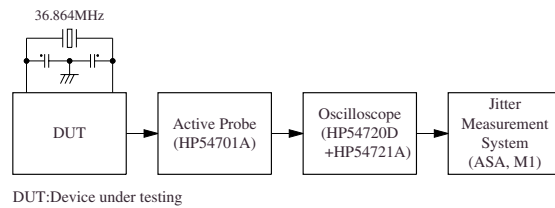

Figure 2. Measurement circuit 2

FUNCTIONAL DESCRIPTION

36.8640MHz Master Clock

The SM8706B 36.8640MHz master clock circuit is configured, as shown in Figure 3, with the crystal oscillator element connected between XTI (pin 7) and XTO (pin 8).

Alternatively, the 36.8640MHz master clock can be supplied from an external master clock input on XTI, as shown in Figure 4.

If an external input clock on XTI is used, it is recommended that the frequency be 36.8640MHz, with 50% duty, and 3.3V voltage amplitude level.

Furthermore, when using an external clock input, the input signal voltage should not exceed the absolute maximum rating, otherwise damage may occur.

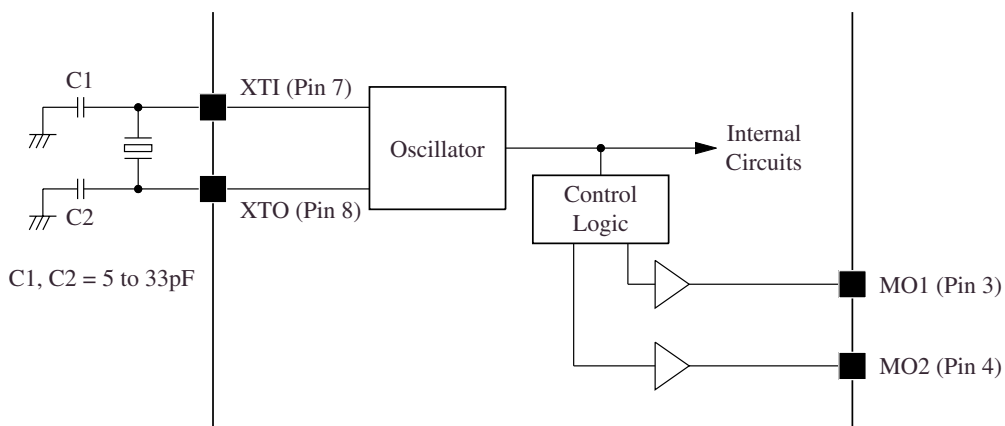

Figure 3. Crystal oscillator connection

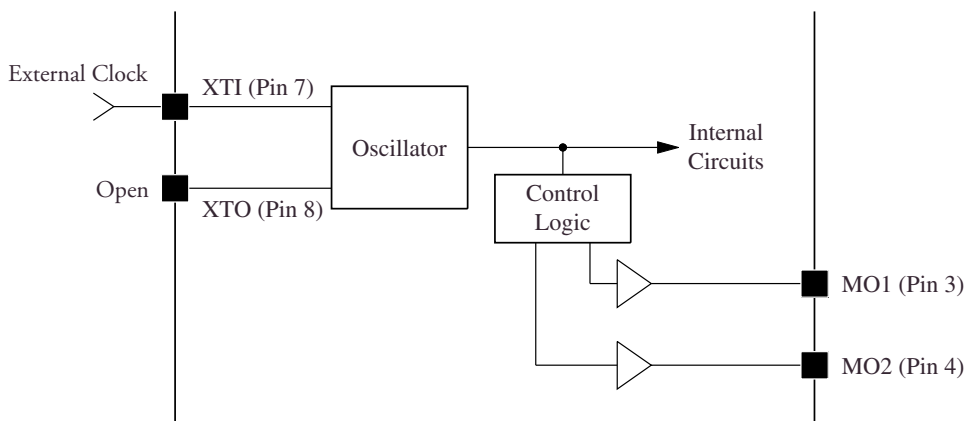

Figure 4. External clock input

Sampling Frequency and Output Clock Frequency

The SM8706B sampling frequency f_s can be switched between 44.1kHz when FSEL (pin 14) is LOW, and 48kHz when FSEL is HIGH. The audio outputs (AO1 and AO2) are a $384f_s$ and $768f_s$ frequency clock, respectively, where f_s is determined by the setting on FSEL. In addition, the signal processor outputs (SO1 and SO2) are a 16.9344MHz and 33.8688MHz frequency clock, respectively, derived from the master clock. The video outputs (MO1 and MO2) are a 27MHz and 54MHz frequency clock, respectively, derived from the master clock.

When CE (Pin16) is HIGH, the chip is enabled. When LOW, the chip is disabled. When disabled, all output go LOW and all internal circuits stop operating. When CE goes LOW to HIGH, the chip moves from disabled to enabled, the time taken until the output frequency clocks stabilize is a maximum of 5ms.

The SM8706B output clock frequencies that can be selected is shown in Table 1. The output clock response timing relative to the CE setting is shown in Figure 5.

Table 1. Sampling frequency and output clock frequency (36.8640MHz master clock frequency)

FSEL (Pin 14)	Sampling frequency f_s [kHz]	CE (Pin 16)	Output clock frequency [MHz]					
			AO1 (Pin 9)	AO2 (Pin 10)	SO1 (Pin 13)	SO2 (Pin 15)	MO1 (Pin 3)	MO2 (Pin 4)
LOW	44.1	H	16.9344	33.8688	16.9344	33.8688	27.0000	54.0000
HIGH	48		18.4320	36.8640	16.9344	33.8688	27.0000	54.0000
LOW	44.1	L	L	L	L	L	L	L
HIGH	48		L	L	L	L	L	L

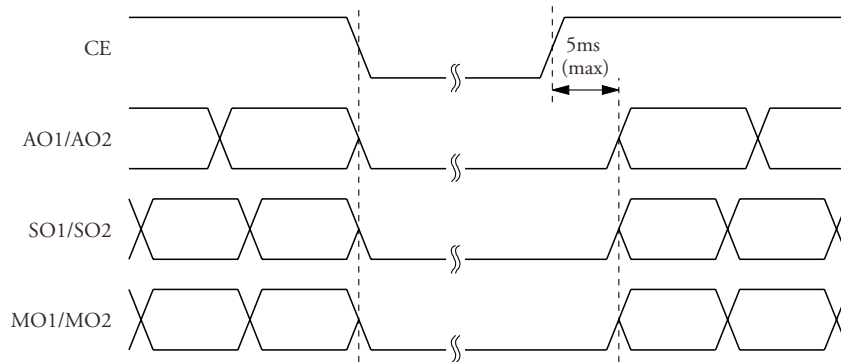

Figure 5. CE switching response

Spike Noise Prevention Function

The SM8706B has a spike noise prevention circuit that operates to prevent the generation of spike noise on the audio output clocks when the sampling frequency is switched using FSEL.

The AO1 and AO2 output clock state before and after FSEL changes state is shown in Figure 6.

When FSEL is switched LOW to HIGH or switched HIGH to LOW, the spike noise circuit stops the AO1 and AO2 outputs for a maximum of 1μs to prevent output spike noise, and then the outputs change to reflect the FSEL setting.

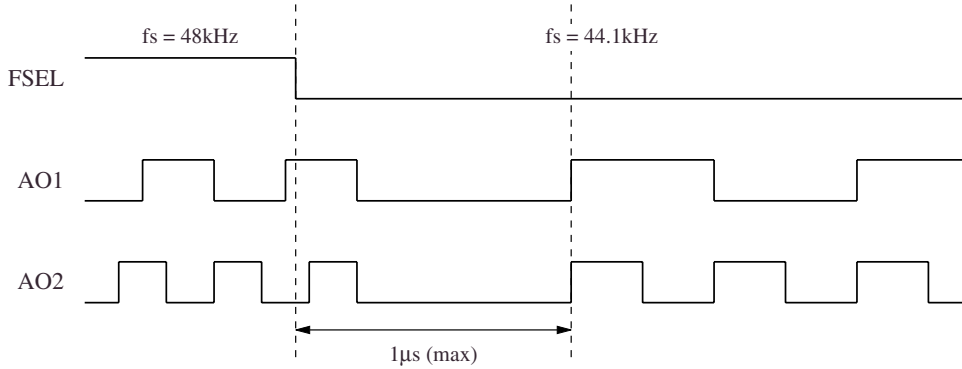

Figure 6. Spike noise prevention circuit timing
(sampling frequency $f_s = 48\text{kHz} \rightarrow f_s = 44.1\text{kHz}$ switching example)

Sampling Frequency Switching Settling Time

The clock output response timing when the sampling frequency f_s is switched using FSEL is shown in Figure 7. The SM8706B has a built-in spike noise prevention circuit. As a result, the AO1 and AO2 outputs stop for a fixed interval after FSEL changes state, as described above, and hence the settling time t_s for the audio output clock when switching the sampling frequency is 1μs maximum.

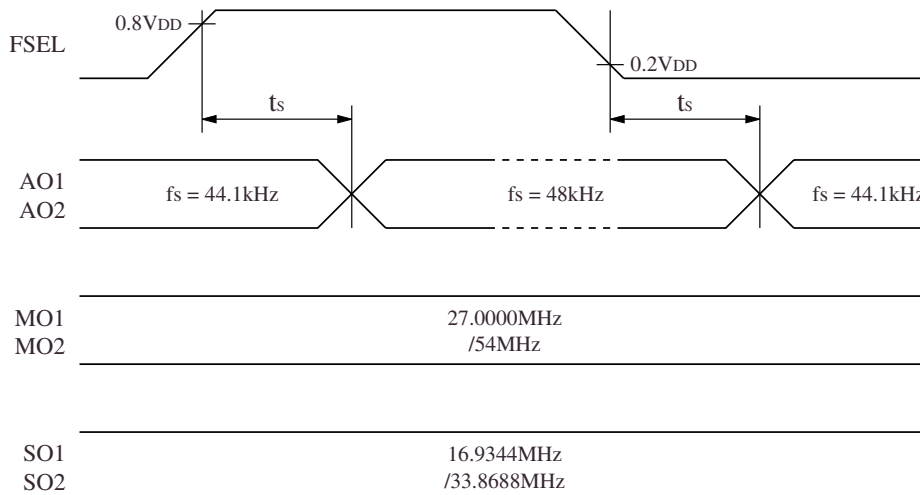
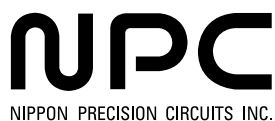

Figure 7. Output signal switching timing

NIPPON PRECISION CIRCUITS INC. reserves the right to make changes to the products described in this data sheet in order to improve the design or performance and to supply the best possible products. Nippon Precision Circuits Inc. assumes no responsibility for the use of any circuits shown in this data sheet, conveys no license under any patent or other rights, and makes no claim that the circuits are free from patent infringement. Applications for any devices shown in this data sheet are for illustration only and Nippon Precision Circuits Inc. makes no claim or warranty that such applications will be suitable for the use specified without further testing or modification. The products described in this data sheet are not intended to use for the apparatus which influence human lives due to the failure or malfunction of the products. Customers are requested to comply with applicable laws and regulations in effect now and hereinafter, including compliance with export controls on the distribution or dissemination of the products. Customers shall not export, directly or indirectly, any products without first obtaining required licenses and approvals from appropriate government agencies.



NIPPON PRECISION CIRCUITS INC.

4-3, Fukuzumi 2-chome, Koto-ku,
Tokyo 135-8430, Japan
Telephone: +81-3-3642-6661
Facsimile: +81-3-3642-6698
<http://www.npc.co.jp/>
Email: sales@npc.co.jp

NC0106AE 2001.06