

OVERVIEW

The SM8145 has independent inductor drive oscillator circuit (OCL1 to OCL3) and EL drive oscillator circuit (OCE) built-in. Accordingly, the frequency of oscillation can be individually changed to control the brightness, current consumption, and frequency over a wide range.

The SM8145 has an EL ON/OFF control pins, ENA1 and ENA2.

DESCRIPTION

The SM8145 comprises an oscillator, booster, and high voltage switching circuit functional blocks.

Block Diagram

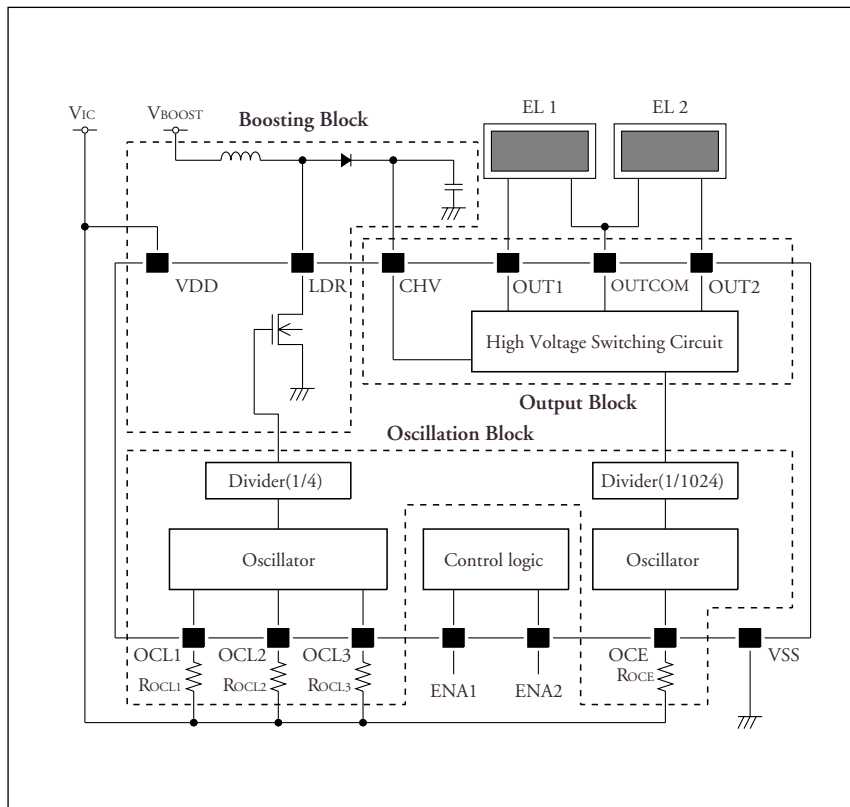

Figure 1. SM8145 Block Diagram

Oscillator

The built-in oscillator circuits require only the connection of an external resistor to form RC oscillator circuits. Changing the value of the external resistor causes the frequency of the oscillator to change. When the resistance is increased, the frequency of oscillation decreases and, conversely, when the resistance is decreased, the frequency of oscillation increases.

The frequency of the oscillator is divided to form two frequency signals, f_{LDR} and f_{OUT} . The f_{LDR} frequency is derived from a 1/4 divider, and f_{OUT} is derived from a 1/1024 divider. The relationship between resistance values and f_{LDR} and f_{OUT} is shown in figures 2 to 5. Note that the measurements shown in the characteristics diagrams were measured using an NPC standard PCB, and that capacitance due to different wiring patterns may have a small effect on these values.

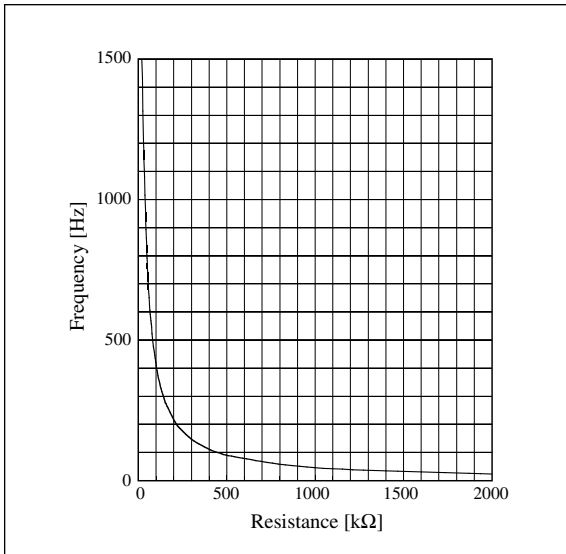

Figure 2. $R_{OCE} - f_{OUT}$

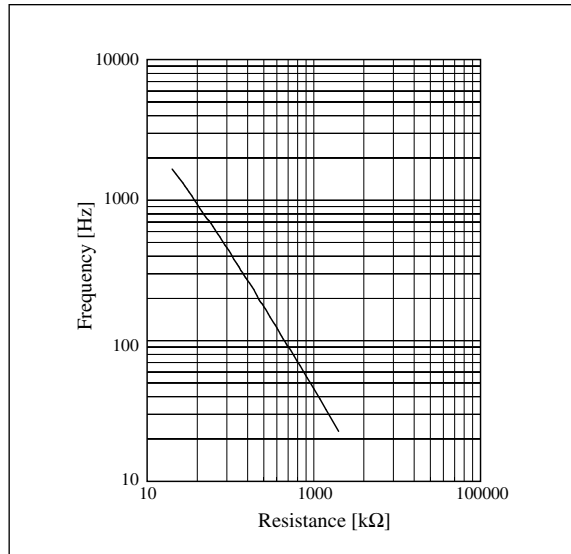

Figure 3. $R_{OCE} - f_{OUT} (LOG)$

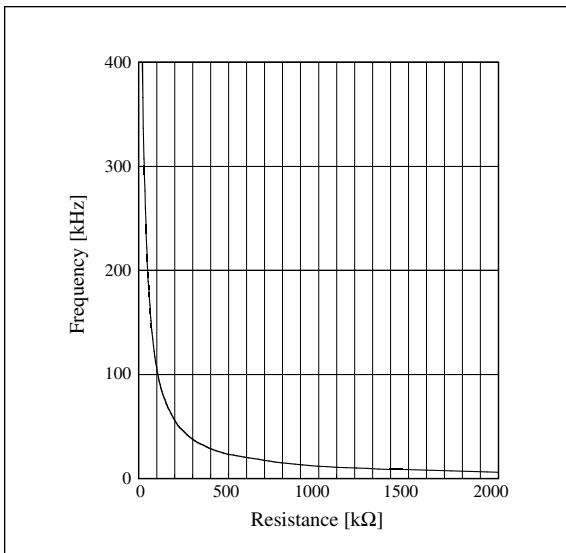

Figure 4. $R_{OCL} - f_{LDR}$

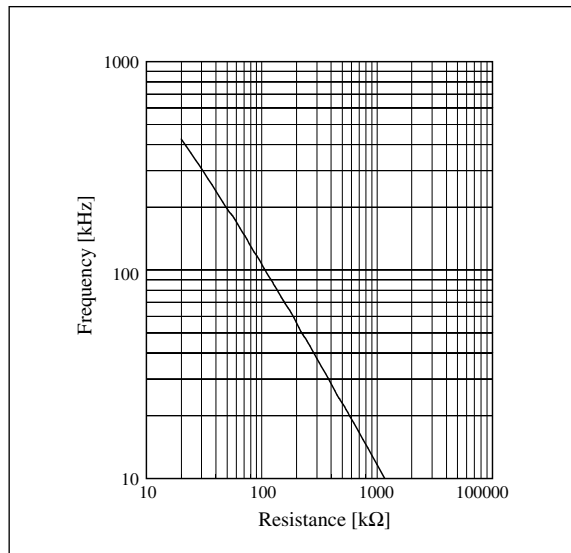

Figure 5. $R_{OCL} - f_{LDR} (LOG)$

Booster

The oscillator frequency is divided by 4 to form the inductor drive clock (f_{LDR}), which is used to switch the inductor drive transistor to boost the voltage from battery-level voltages up to a maximum of 100V DC. The switching duty ratio is fixed with a cycle of 75% ON and 25% OFF. When the inductor drive transistor is ON, the inductor current flows through the inductor drive transistor, as shown in the following figure.

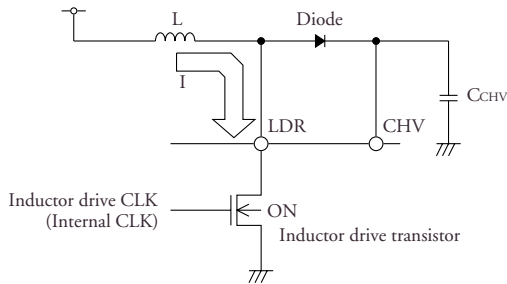

Figure 6. Boost circuit (transistor ON)

The current I [A] is a function of the coil inductance L [H], the voltage across the inductor V [V], and the inductor drive transistor ON time t_{ON} [sec], given by:

$$I = \left(\frac{V}{L}\right) \times t_{ON} \text{ [A]}$$

and the inductor stores this energy as magnetic energy. When the inductor drive transistor is OFF, the current in the inductor drive transistor necessarily reduces to zero. However, the inductor current naturally continues to flow and is redirected through the diode and capacitor, which stores the energy as electric energy. At this point, a counter emf appears on pin LDR.

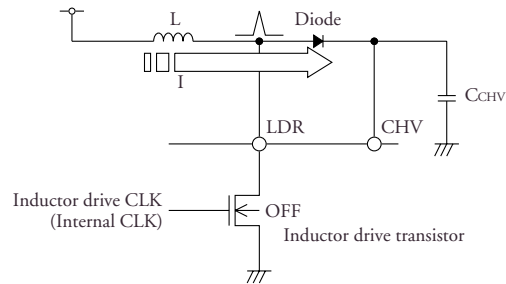

Figure 7. Boost circuit (transistor OFF)

This operation repeats as the transistor is switched ON and OFF, thereby boosting the voltage on pin CHV to stabilize the power consumption in the EL output stage. Note that the rating for the voltage on CHV is 100V maximum, so care should be taken not to exceed this value.

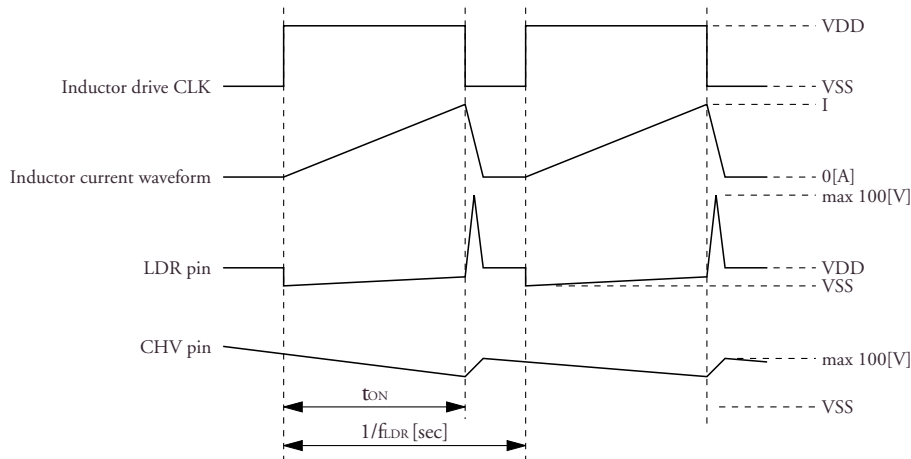

Figure 8. Boost circuit timing

The inductor drive clock duty ratio is 75%, and therefore the voltage is applied to the inductor for time t_{ON} , given by:

$$t_{ON} = 0.75 \times \frac{1}{f_{LDR}} \text{ [sec]}$$

and the energy stored in the inductor (E) is given by:

$$E = \frac{1}{2} \times f_{LDR} \times L \times I^2 \approx 0.28 \times \frac{V^2}{f_{LDR} \times L}$$

Output Stage

The high voltage created in the booster stage is passed to the output stage and three signals OUT1, OUT2, and OUTCOM from a bridge circuit are out-

For example, if the frequency is halved, then the ON time for which current flows through the inductor is doubled, the current through the inductor is also doubled, and the energy stored in the inductance coil is also doubled. Also, if the coil inductance is halved, then the current and energy are doubled. If the voltage is doubled, then the current is doubled and the energy is quadrupled.

The booster energy can be adjusted by controlling the coil inductance drive frequency, the inductance of the coil, and the voltage across the inductor to meet the desired application.

put at a frequency f_{OUT} generated by the oscillator. The output frequency can be adjusted using the external resistance values of R_{OCE} .

Output Waveform

Ideally, the SM8145 output waveform for efficient EL illumination is a rectangular-like drive waveform as shown in figure 10. If the EL element oscillates in a particular application, then the output waveform can be slightly smoothed by adjusting an output

resistor R_{OUT} shown in figure 9. The output waveform is smoother for higher values of resistance for R_{OUT} , which will help control noise but at the expense of higher loss.

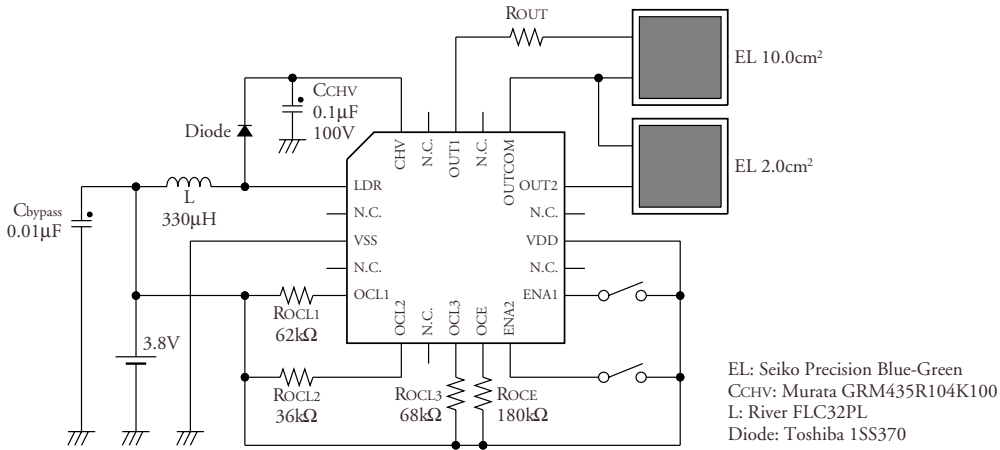

Figure 9. Output waveform adjustment circuit

The effect of R_{OUT} for values of 0, 5.1kΩ, 10kΩ, and 20kΩ are shown in the following table and figures.

R_{OUT} [kΩ]	R_{OCL} [kΩ]	R_{OCE} [kΩ]	Current consumption [mA]	f_{OUT} [Hz]	V_{OUT} [Vp-p]	Brightness [cd/m ²]	Waveform
0.0	62	180	17.7	198	232	29.1	Figure 10
5.1	62	180	17.5	198	232	28.9	Figure 11
10.0	62	180	17.5	197	232	27.6	Figure 12
20.0	62	180	17.6	194	232	26.2	Figure 13

Note. R_{OUT} is only connected to OUT1 in the Output waveform adjustment circuit (Fig.9), however, please connect it to OUT1 or/and OUT2 according to the condition.

Note. Connect a 1kΩ resistor between output pins (OUT1, OUT2) and EL terminal when the EL is over 20cm² per channel.

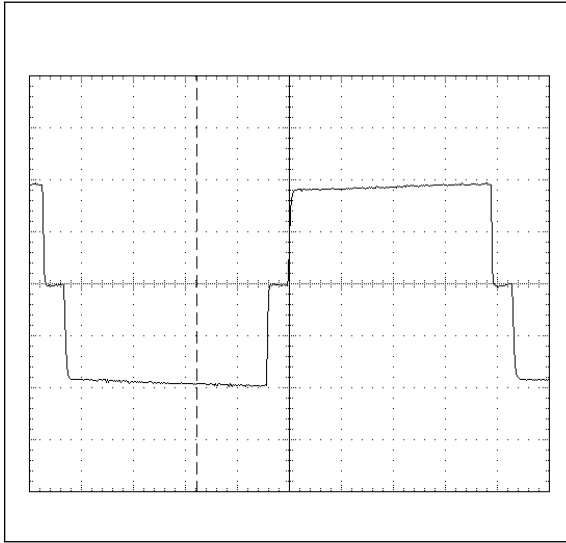

Figure 10. $R_{OUT} = 0$

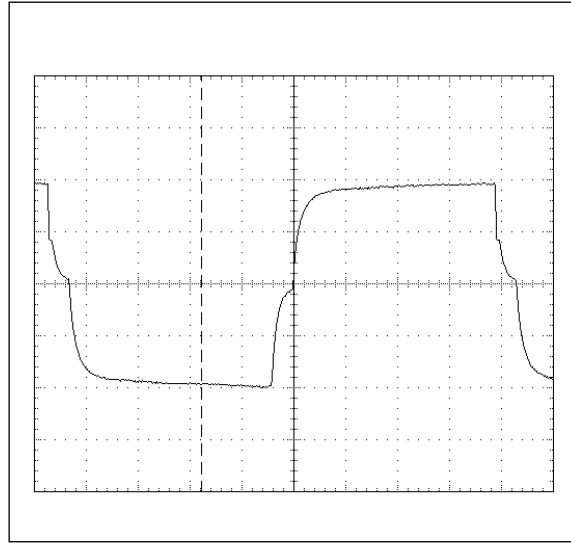

Figure 12. $R_{OUT} = 10k\Omega$

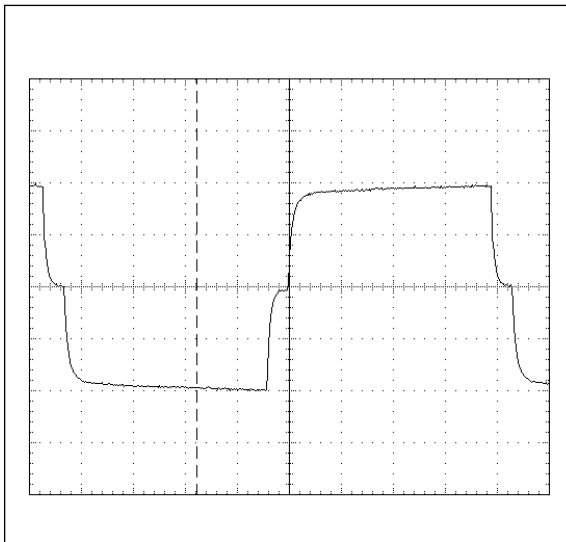

Figure 11. $R_{OUT} = 5.1k\Omega$

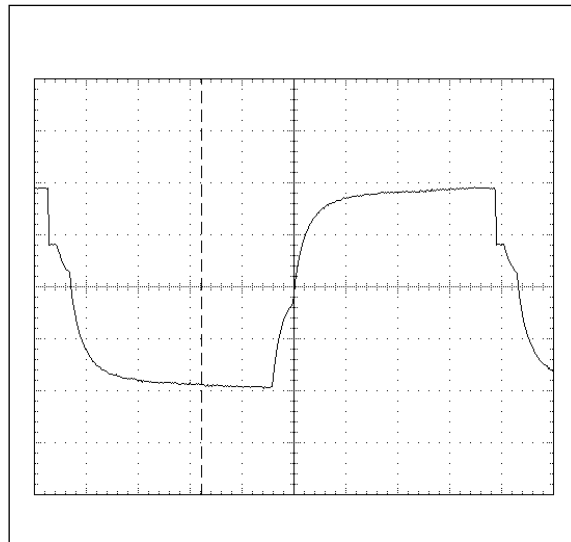

Figure 13. $R_{OUT} = 20k\Omega$

TYPICAL APPLICATION CIRCUIT

The inductance, R_{OCL1} to R_{OCL3} , and R_{OCE} can all be adjusted to control the brightness and current consumption required in a particular application.

R_{OCE} is the resistor connected to pin OCE. Changing the resistance changes the output frequency. Values should be within the range 24 k Ω to 1000 k Ω . A high resistance reduces the output frequency. Care should be taken not to exceed the maximum rating as the output voltage will be high level if the output frequency is set to low, even if the brightness or the current through the inductor is fixed.

R_{OCL1} to R_{OCL3} is the resistor connected to pin OCL1 to OCL3. Changing the resistance changes the inductor switching frequency, which also changes

the inductor current and EL brightness. Values should be within the range 24 k Ω to 1000 k Ω . A high resistance reduces the inductor switching frequency and increases the current. Care should be taken not to exceed the rated maximum inductor current for high values of R_{OCL} resistance.

R_{OCL1} to R_{OCL3} is each output mode adjustment resistance: R_{OCL1} is EL1 (OUT1) drive, R_{OCL2} is EL2 (OUT2) drive, and R_{OCL3} is EL1 + EL2 (OUT1 + OUT2) drive.

From the next page, the examples of the application values and circuits in the typical combination of supply voltage and two EL are mentioned.

	V_{DD} [V]	EL1 [cm ²]	EL2 [cm ²]	Output frequency
1	5.0	30.0	30.0	$R_{OCE} = 180k\Omega$: approximately 250Hz $R_{OCE} = 110k\Omega$: approximately 400Hz
2	3.0	30.0	10.0	
3	3.8	30.0	10.0	
4	3.0	20.0	10.0	
5	3.8	20.0	10.0	
6	3.0	15.0	4.0	
7	3.8	15.0	4.0	
8	3.0	10.0	2.0	
9	3.8	10.0	2.0	

$V_{DD} : 5.0 [V]$, $EL1: 30.0 [cm^2]$, $EL2: 30.0 [cm^2]$, Inductor: Panasonic ELL6SH

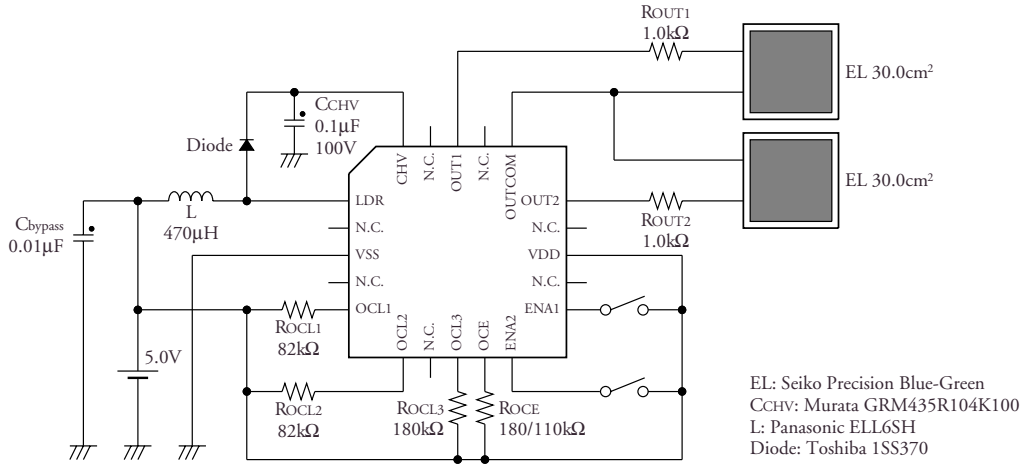

Figure 14. Application circuit

$R_{OCL1,2}$ typical application values ($EL1: 30.0 [cm^2]$)

$R_{OCE}: 180 [k\Omega]$

Inductance [μH]	$R_{OCL1,2} [k\Omega]$	Current consumption [mA]	$V_{OUT} [Vp-p]$	Brightness [cd/m^2]
330	100	31.1	193	26.6
470	82	20.9	159	19.7
470	51	14.2	139	14.1

$R_{OCE}: 110 [k\Omega]$

Inductance [μH]	$R_{OCL1,2} [k\Omega]$	Current consumption [mA]	$V_{OUT} [Vp-p]$	Brightness [cd/m^2]
330	130	39.1	171	31.4
470	82	21.1	135	18.7
470	51	15.3	118	13.6

R_{OCL3} typical application values ($EL1 + EL2: 60.0 [cm^2]$)

$R_{OCE}: 180 [k\Omega]$

Inductance [μH]	$R_{OCL3} [k\Omega]$	Current consumption [mA]	$V_{OUT} [Vp-p]$	Brightness [cd/m^2]
470	180	44.7	169	20.2
470	100	27.8	141	14.0
330	51	19.3	120	9.6

$R_{OCE}: 110 [k\Omega]$

Inductance [μH]	$R_{OCL3} [k\Omega]$	Current consumption [mA]	$V_{OUT} [Vp-p]$	Brightness [cd/m^2]
470	180	45.9	140	18.7
330	100	32.3	122	13.7
470	82	22.8	106	9.5

Note. The highlighted part in the table indicates the settings in the application circuit above.

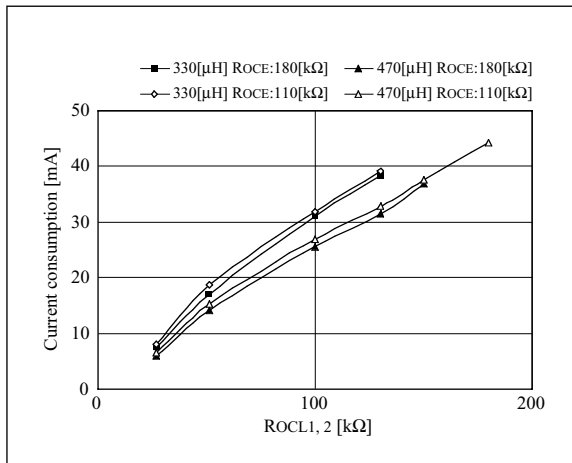

Figure 15. ROCL1, 2 – Current consumption

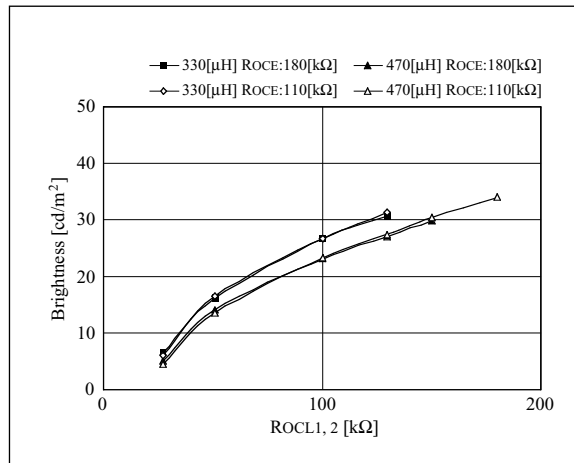

Figure 16. ROCL1, 2 – Brightness

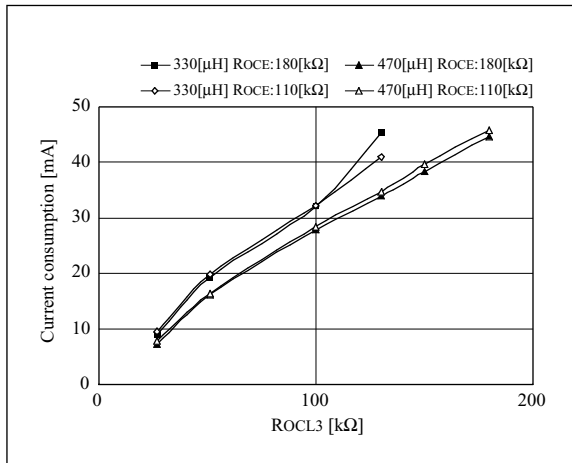

Figure 17. ROCL3 – Current consumption

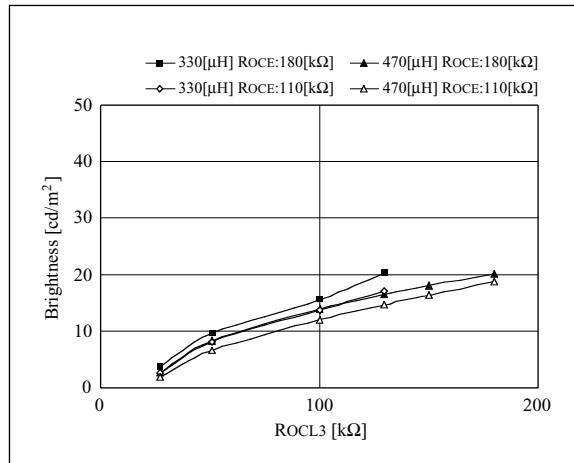

Figure 18. ROCL3 – Brightness

$V_{DD} : 3.0 [V]$, $EL1: 30.0 [cm^2]$, $EL2: 10.0 [cm^2]$, Inductor: Panasonic ELL6SH

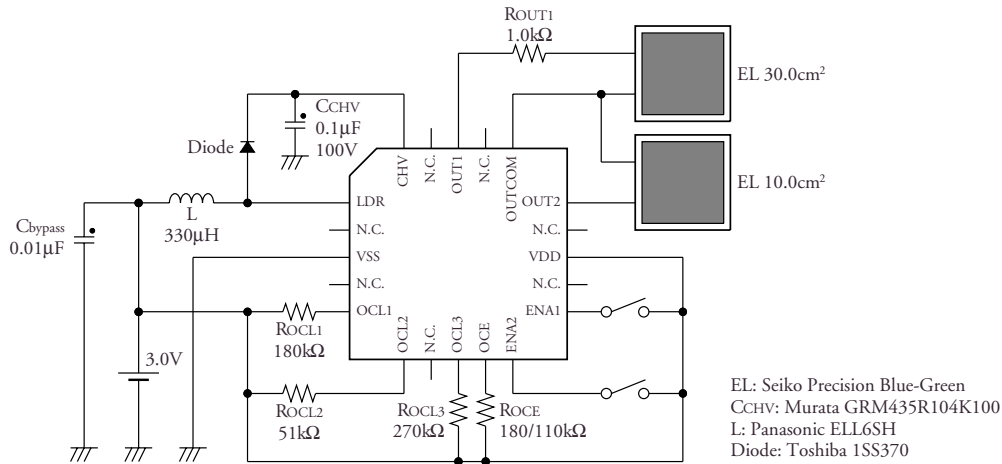

Figure 19. Application circuit

R_{OCL1} typical application values ($EL1: 30.0 [cm^2]$)

$R_{OCE}: 180 [k\Omega]$

Inductance [μH]	$R_{OCL1} [k\Omega]$	Current consumption [mA]	$V_{OUT} [Vp-p]$	Brightness [cd/m^2]
330	270	46.5	168	20.6
330	180	31.0	147	15.9
470	130	19.6	124	10.6

$R_{OCE}: 110 [k\Omega]$

Inductance [μH]	$R_{OCL1} [k\Omega]$	Current consumption [mA]	$V_{OUT} [Vp-p]$	Brightness [cd/m^2]
470	360	54.0	143	20.5
330	180	31.1	123	14.4
470	130	20.1	105	9.6

R_{OCL2} typical application values ($EL2: 10.0 [cm^2]$)

$R_{OCE}: 180 [k\Omega]$

Inductance [μH]	$R_{OCL2} [k\Omega]$	Current consumption [mA]	$V_{OUT} [Vp-p]$	Brightness [cd/m^2]
330	130	21.8	196	29.6
470	82	13.3	158	20.5
330	51	8.5	127	12.9

$R_{OCE}: 110 [k\Omega]$

Inductance [μH]	$R_{OCL2} [k\Omega]$	Current consumption [mA]	$V_{OUT} [Vp-p]$	Brightness [cd/m^2]
330	180	30.9	189	37.9
470	100	14.8	141	21.8
330	51	9.3	113	12.9

R_{OCL3} typical application values ($EL1 + EL2: 40.0 [cm^2]$)

$R_{OCE}: 180 [k\Omega]$

Inductance [μH]	$R_{OCL3} [k\Omega]$	Current consumption [mA]	$V_{OUT} [Vp-p]$	Brightness [cd/m^2]
330	270	46.5	149	15.5
470	180	27.5	126	11.0
470	130	20.8	113	8.5

$R_{OCE}: 110 [k\Omega]$

Inductance [μH]	$R_{OCL3} [k\Omega]$	Current consumption [mA]	$V_{OUT} [Vp-p]$	Brightness [cd/m^2]
330	270	47.6	125	14.4
470	270	40.2	119	13.0
330	130	24.9	101	8.3

Note. The highlighted part in the table indicates the settings in the application circuit above.

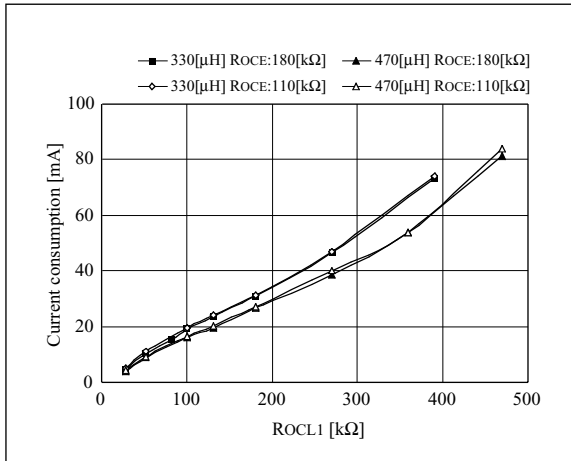

Figure 20. R_{OCL1} – Current consumption

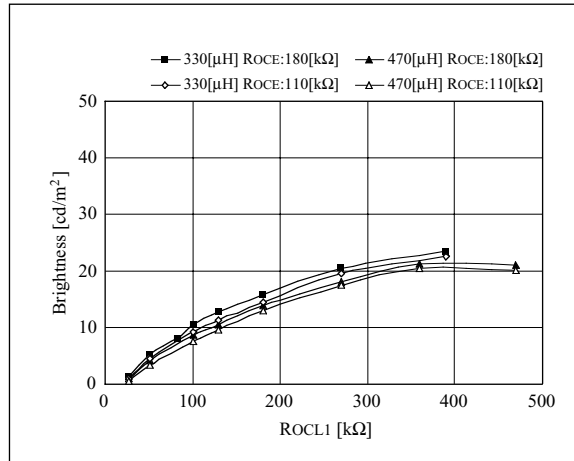

Figure 21. R_{OCL1} – Brightness

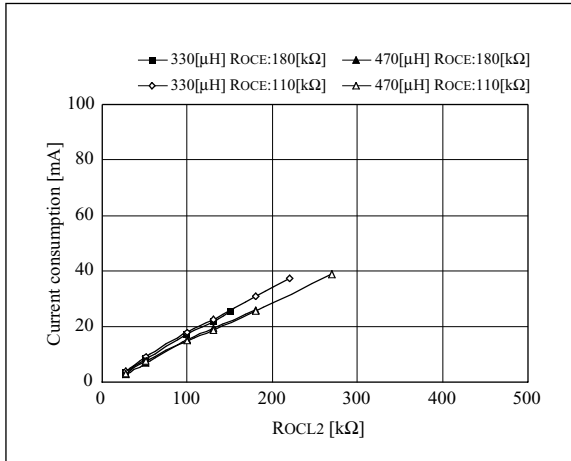

Figure 22. R_{OCL2} – Current consumption

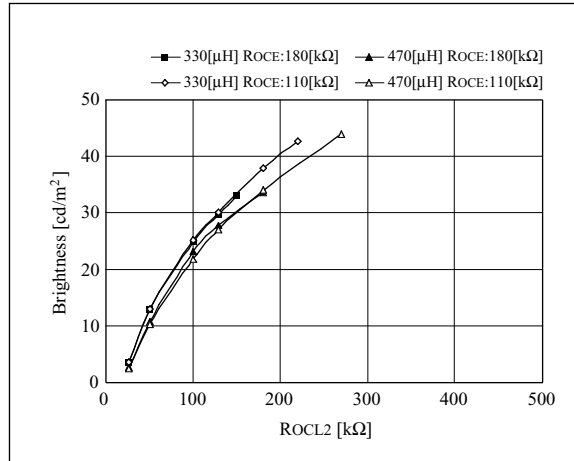

Figure 23. R_{OCL2} – Brightness

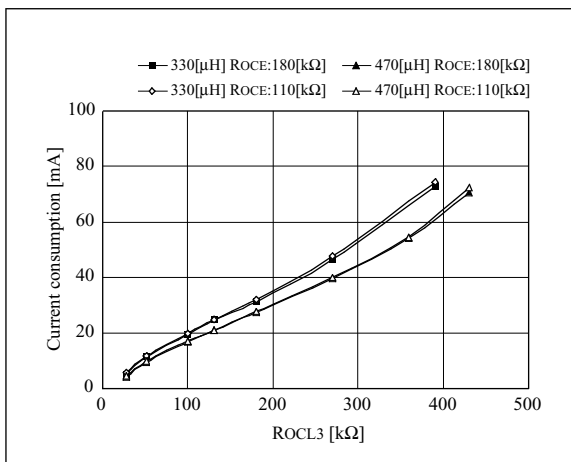

Figure 24. R_{OCL3} – Current consumption

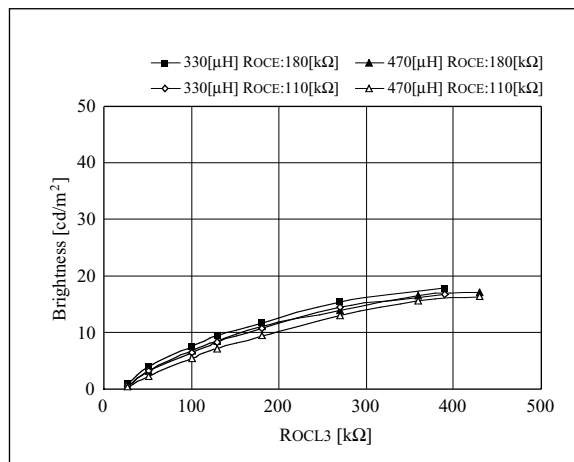

Figure 25. R_{OCL3} – Brightness

$V_{DD} : 3.8 [V]$, $EL1: 30.0 [cm^2]$, $EL2: 10.0 [cm^2]$, Inductor: Panasonic ELL6SH

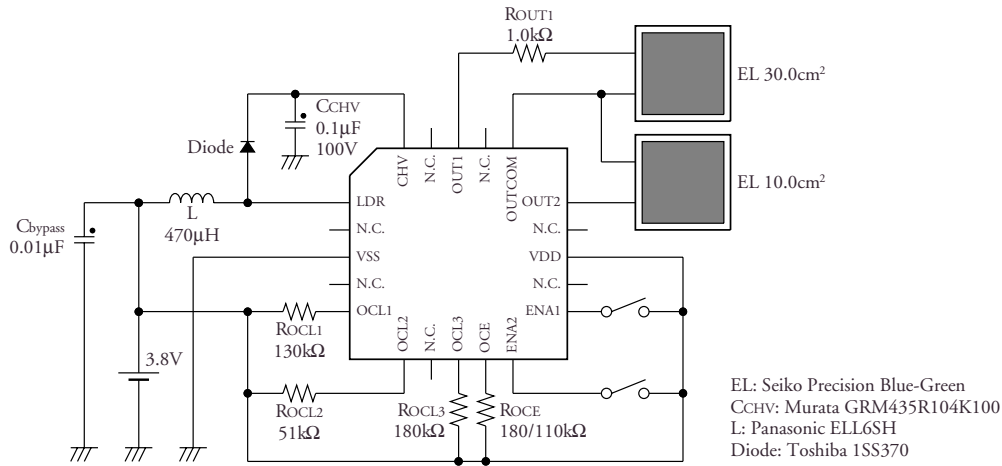

Figure 26. Application circuit

R_{OCL1} typical application values ($EL1: 30.0 [cm^2]$)

$R_{OCE}: 180 [k\Omega]$

Inductance [μH]	R_{OCL1} [$k\Omega$]	Current consumption [mA]	V_{OUT} [Vp-p]	Brightness [cd/m^2]
330	180	39.1	181	23.6
470	130	24.7	152	17.0
470	82	16.6	131	12.3

$R_{OCE}: 110 [k\Omega]$

Inductance [μH]	R_{OCL1} [$k\Omega$]	Current consumption [mA]	V_{OUT} [Vp-p]	Brightness [cd/m^2]
470	300	55.6	167	28.9
470	130	25.1	128	15.8
330	51	13.9	99	8.7

R_{OCL2} typical application values ($EL2: 10.0 [cm^2]$)

$R_{OCE}: 180 [k\Omega]$

Inductance [μH]	R_{OCL2} [$k\Omega$]	Current consumption [mA]	V_{OUT} [Vp-p]	Brightness [cd/m^2]
470	82	16.4	195	29.1
330	51	10.8	158	19.6
470	51	8.7	146	16.4

$R_{OCE}: 110 [k\Omega]$

Inductance [μH]	R_{OCL2} [$k\Omega$]	Current consumption [mA]	V_{OUT} [Vp-p]	Brightness [cd/m^2]
470	130	23.8	192	40.5
330	82	19.7	176	34.6
470	51	9.5	128	17.9

R_{OCL3} typical application values ($EL1 + EL2: 40.0 [cm^2]$)

$R_{OCE}: 180 [k\Omega]$

Inductance [μH]	R_{OCL3} [$k\Omega$]	Current consumption [mA]	V_{OUT} [Vp-p]	Brightness [cd/m^2]
470	300	54.7	178	21.7
470	180	33.8	153	16.0
330	82	20.3	125	10.2

$R_{OCE}: 110 [k\Omega]$

Inductance [μH]	R_{OCL3} [$k\Omega$]	Current consumption [mA]	V_{OUT} [Vp-p]	Brightness [cd/m^2]
470	270	50.4	146	21.3
470	180	35.0	129	16.3
330	82	20.7	105	9.7

Note. The highlighted part in the table indicates the settings in the application circuit above.

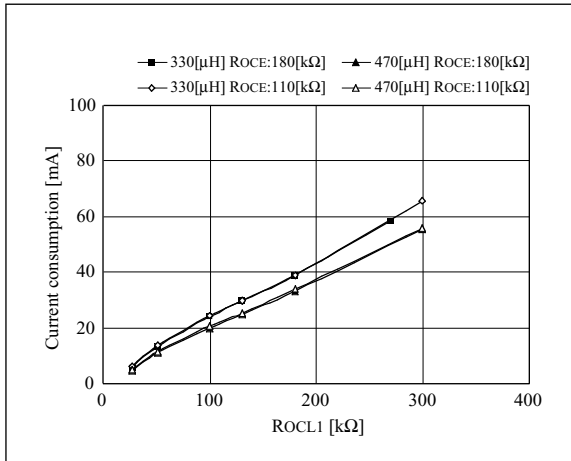

Figure 27. R_{OCL1} – Current consumption

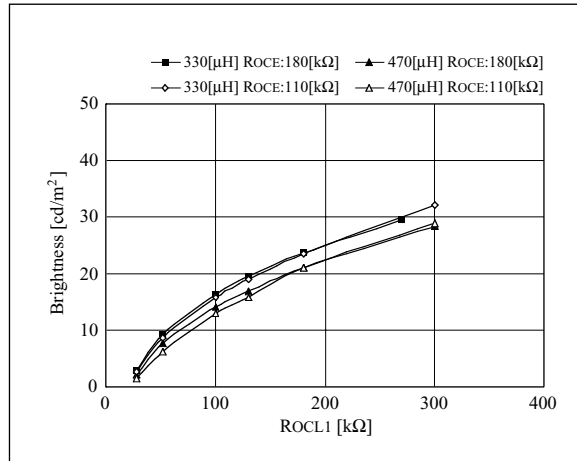

Figure 28. R_{OCL1} – Brightness

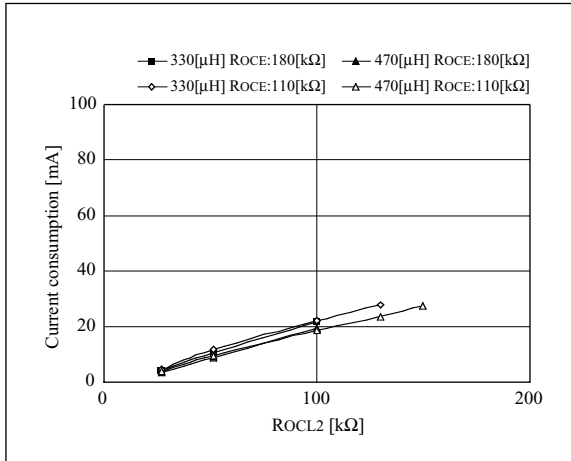

Figure 29. R_{OCL2} – Current consumption

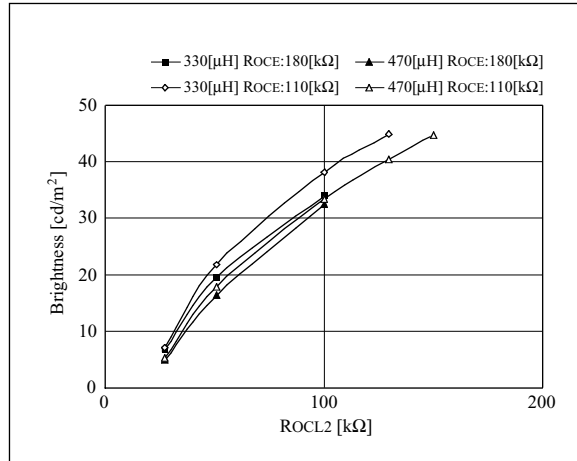

Figure 30. R_{OCL2} – Brightness

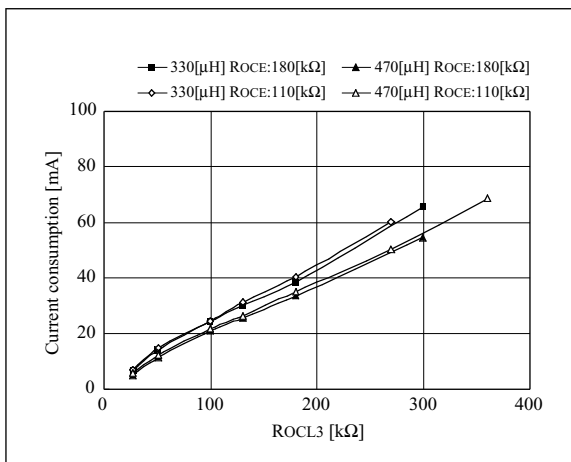

Figure 31. R_{OCL3} – Current consumption

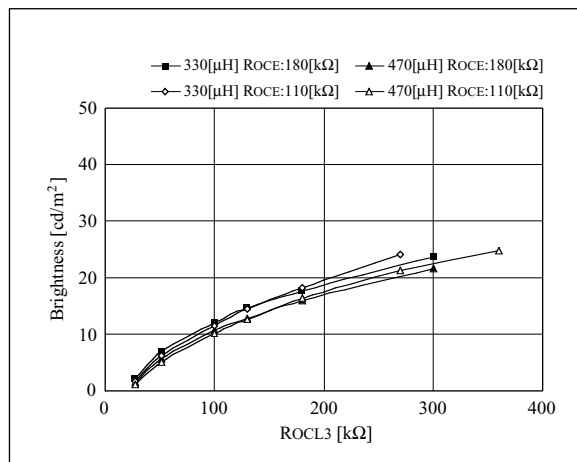

Figure 32. R_{OCL3} – Brightness

$V_{DD} : 3.0 [V]$, $EL1: 20.0 [cm^2]$, $EL2: 10.0 [cm^2]$, Inductor: TOKO D52FU-875FU

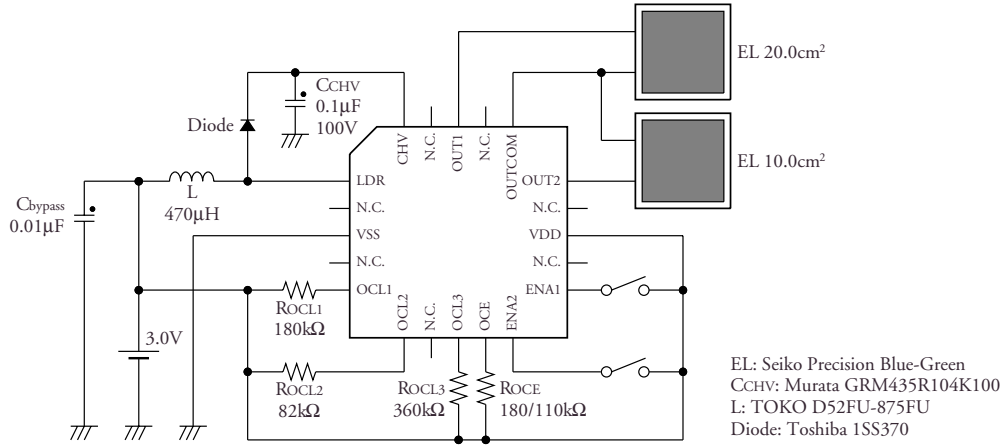

Figure 33. Application circuit

R_{OCL1} typical application values ($EL1: 20.0 [cm^2]$)

$R_{OCE}: 180 [k\Omega]$

Inductance [μH]	$R_{OCL1} [k\Omega]$	Current consumption [mA]	$V_{OUT} [Vp-p]$	Brightness [cd/m^2]
330	180	38.3	182	26.8
470	180	26.7	164	21.8
330	51	12.1	118	10.9

$R_{OCE}: 110 [k\Omega]$

Inductance [μH]	$R_{OCL1} [k\Omega]$	Current consumption [mA]	$V_{OUT} [Vp-p]$	Brightness [cd/m^2]
330	270	56.8	166	30.6
470	180	27.0	136	20.3
470	82	14.2	108	11.4

R_{OCL2} typical application values ($EL2: 10.0 [cm^2]$)

$R_{OCE}: 180 [k\Omega]$

Inductance [μH]	$R_{OCL2} [k\Omega]$	Current consumption [mA]	$V_{OUT} [Vp-p]$	Brightness [cd/m^2]
330	100	21.5	193	28.3
470	82	13.3	163	20.4
470	51	6.8	118	10.6

$R_{OCE}: 110 [k\Omega]$

Inductance [μH]	$R_{OCL2} [k\Omega]$	Current consumption [mA]	$V_{OUT} [Vp-p]$	Brightness [cd/m^2]
330	130	28.2	183	35.8
470	82	13.8	139	21.1
470	51	7.2	104	10.6

R_{OCL3} typical application values ($EL1 + EL2: 30.0 [cm^2]$)

$R_{OCE}: 180 [k\Omega]$

Inductance [μH]	$R_{OCL3} [k\Omega]$	Current consumption [mA]	$V_{OUT} [Vp-p]$	Brightness [cd/m^2]
470	360	55.7	165	19.6
330	130	30.0	144	14.7
470	130	20.5	125	10.9

$R_{OCE}: 110 [k\Omega]$

Inductance [μH]	$R_{OCL3} [k\Omega]$	Current consumption [mA]	$V_{OUT} [Vp-p]$	Brightness [cd/m^2]
470	360	55.9	137	18.2
330	130	30.0	121	13.2
470	130	21.0	106	9.6

Note. The highlighted part in the table indicates the settings in the application circuit above.

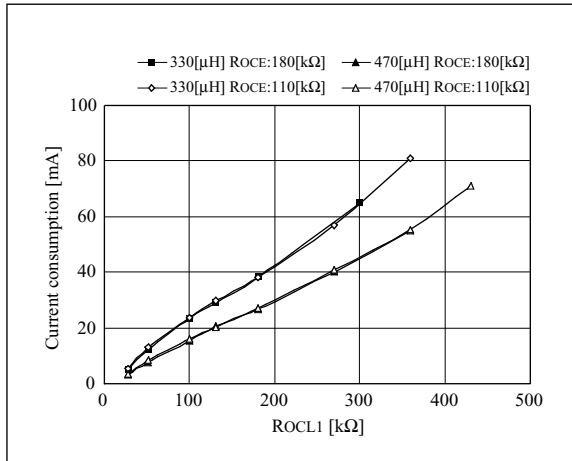

Figure 34. R_{OCL1} – Current consumption

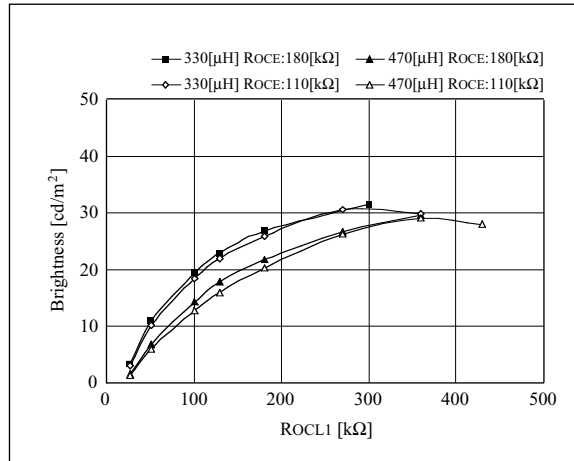

Figure 35. R_{OCL1} – Brightness

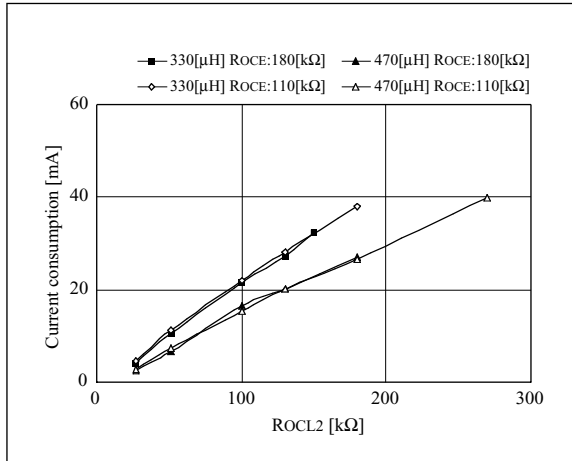

Figure 36. R_{OCL2} – Current consumption

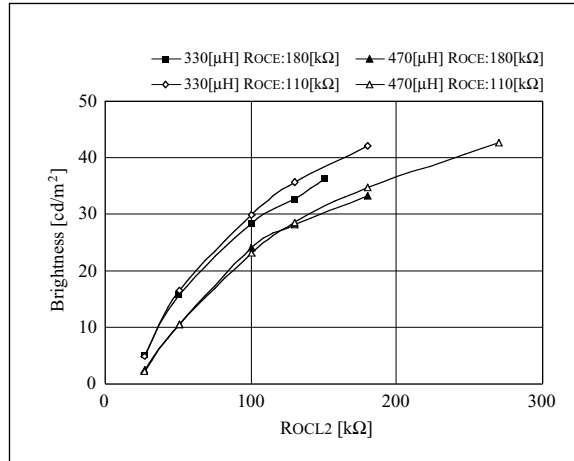

Figure 37. R_{OCL2} – Brightness

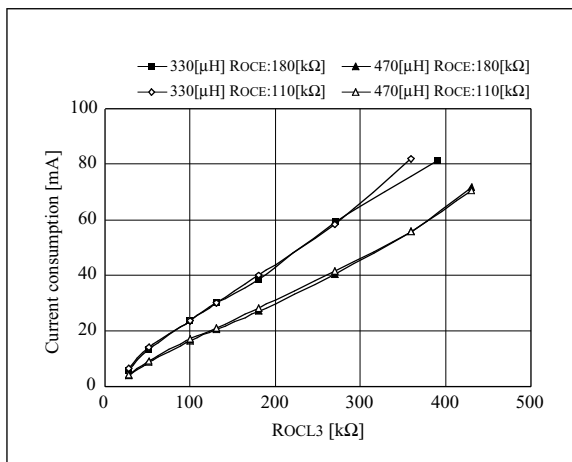

Figure 38. R_{OCL3} – Current consumption

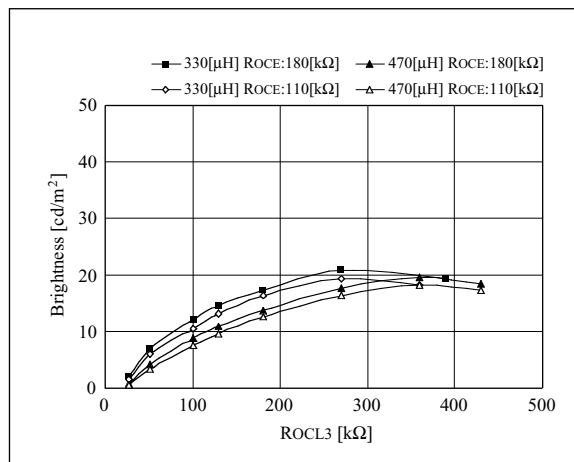

Figure 39. R_{OCL3} – Brightness

$V_{DD} : 3.8 [V]$, $EL1: 20.0 [cm^2]$, $EL2: 10.0 [cm^2]$, Inductor: TOKO D52FU-875FU

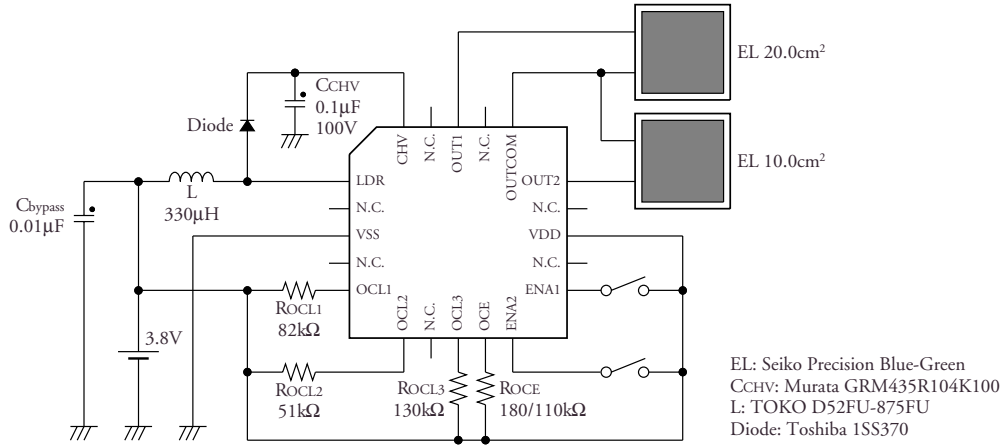

Figure 40. Application circuit

R_{OCL1} typical application values ($EL1: 20.0 [cm^2]$)

$R_{OCE}: 180 [k\Omega]$

Inductance [μH]	$R_{OCL1} [k\Omega]$	Current consumption [mA]	$V_{OUT} [Vp-p]$	Brightness [cd/m^2]
330	100	29.8	192	28.6
330	82	18.3	162	20.7
470	51	10.2	123	12.0

$R_{OCE}: 110 [k\Omega]$

Inductance [μH]	$R_{OCL1} [k\Omega]$	Current consumption [mA]	$V_{OUT} [Vp-p]$	Brightness [cd/m^2]
330	180	48.4	188	39.2
330	82	23.9	147	24.2
470	51	10.9	107	11.3

R_{OCL2} typical application values ($EL2: 10.0 [cm^2]$)

$R_{OCE}: 180 [k\Omega]$

Inductance [μH]	$R_{OCL2} [k\Omega]$	Current consumption [mA]	$V_{OUT} [Vp-p]$	Brightness [cd/m^2]
470	82	16.7	198	29.6
330	51	13.0	176	23.6
330	36	7.9	139	14.9

$R_{OCE}: 110 [k\Omega]$

Inductance [μH]	$R_{OCL2} [k\Omega]$	Current consumption [mA]	$V_{OUT} [Vp-p]$	Brightness [cd/m^2]
330	82	24.8	195	41.4
330	51	14.3	154	26.9
470	51	9.4	130	19.0

R_{OCL3} typical application values ($EL1 + EL2: 30.0 [cm^2]$)

$R_{OCE}: 180 [k\Omega]$

Inductance [μH]	$R_{OCL3} [k\Omega]$	Current consumption [mA]	$V_{OUT} [Vp-p]$	Brightness [cd/m^2]
330	180	48.3	193	26.6
330	130	36.7	177	22.7
470	82	18.0	134	13.0

$R_{OCE}: 110 [k\Omega]$

Inductance [μH]	$R_{OCL3} [k\Omega]$	Current consumption [mA]	$V_{OUT} [Vp-p]$	Brightness [cd/m^2]
330	220	61.4	171	31.3
330	130	37.8	147	23.4
470	100	22.1	122	15.1

Note. The highlighted part in the table indicates the settings in the application circuit above.

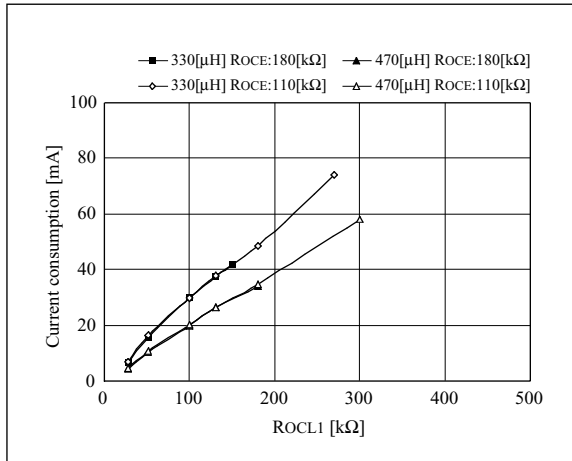

Figure 41. R_{OCL1} – Current consumption

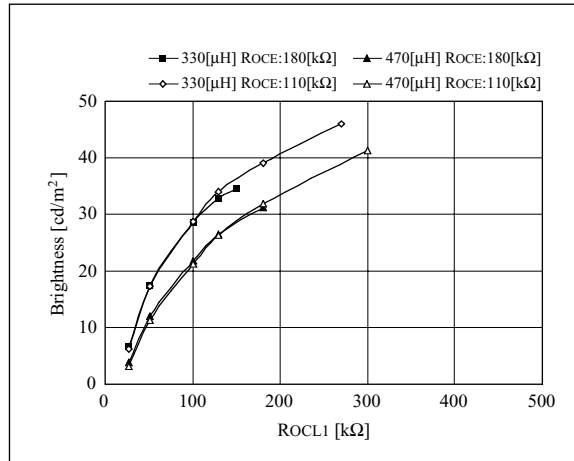

Figure 42. R_{OCL1} – Brightness

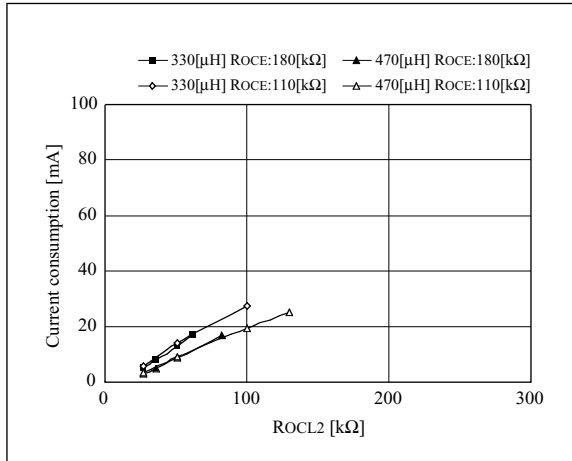

Figure 43. R_{OCL2} – Current consumption

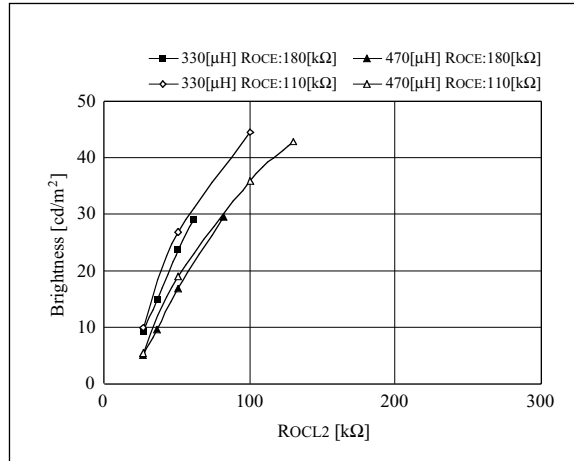

Figure 44. R_{OCL2} – Brightness

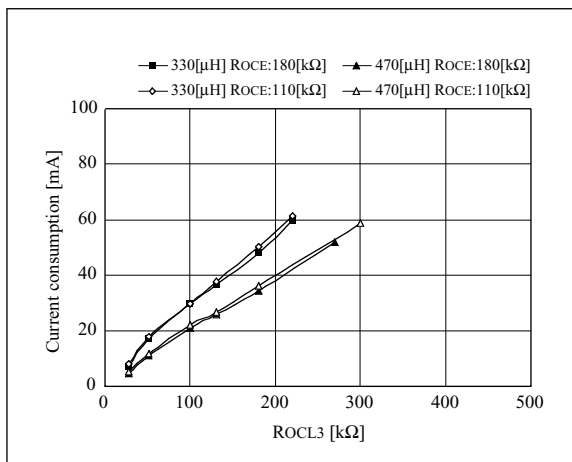

Figure 45. R_{OCL3} – Current consumption

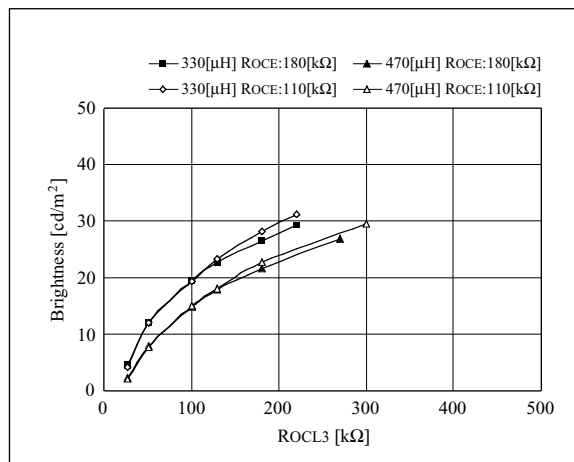

Figure 46. R_{OCL3} – Brightness

$V_{DD} : 3.0 [V]$, $EL1: 15.0 [cm^2]$, $EL2: 4.0 [cm^2]$, Inductor: Murata LQH4N

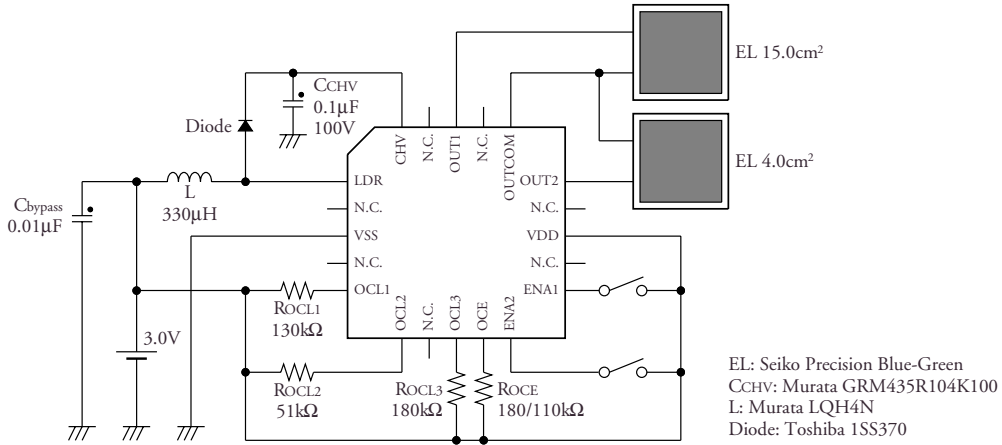

Figure 47. Application circuit

R_{OCL1} typical application values ($EL1: 15.0 [cm^2]$)

$R_{OCE}: 180 [k\Omega]$

Inductance [μH]	$R_{OCL1} [k\Omega]$	Current consumption [mA]	$V_{OUT} [Vp-p]$	Brightness [cd/m^2]
330	130	28.7	183	26.7
470	130	20.8	164	21.7
330	51	11.1	127	12.6

$R_{OCE}: 110 [k\Omega]$

Inductance [μH]	$R_{OCL1} [k\Omega]$	Current consumption [mA]	$V_{OUT} [Vp-p]$	Brightness [cd/m^2]
330	270	56.8	184	36.0
330	130	29.0	156	26.9
470	130	20.3	136	20.4

R_{OCL2} typical application values ($EL2: 4.0 [cm^2]$)

$R_{OCE}: 180 [k\Omega]$

Inductance [μH]	$R_{OCL2} [k\Omega]$	Current consumption [mA]	$V_{OUT} [Vp-p]$	Brightness [cd/m^2]
470	82	10.7	195	32.5
330	51	8.0	167	24.6
470	51	5.2	138	16.9

$R_{OCE}: 110 [k\Omega]$

Inductance [μH]	$R_{OCL2} [k\Omega]$	Current consumption [mA]	$V_{OUT} [Vp-p]$	Brightness [cd/m^2]
330	68	13.6	187	42.7
330	51	9.0	153	30.2
470	51	5.8	127	20.6

R_{OCL3} typical application values ($EL1 + EL2: 19.0 [cm^2]$)

$R_{OCE}: 180 [k\Omega]$

Inductance [μH]	$R_{OCL3} [k\Omega]$	Current consumption [mA]	$V_{OUT} [Vp-p]$	Brightness [cd/m^2]
330	180	38.5	180	25.6
330	100	23.4	153	18.7
470	100	15.9	131	13.3

$R_{OCE}: 110 [k\Omega]$

Inductance [μH]	$R_{OCL3} [k\Omega]$	Current consumption [mA]	$V_{OUT} [Vp-p]$	Brightness [cd/m^2]
330	180	39.2	153	25.8
330	100	24.6	132	19.0
470	100	16.5	114	13.0

Note. The highlighted part in the table indicates the settings in the application circuit above.

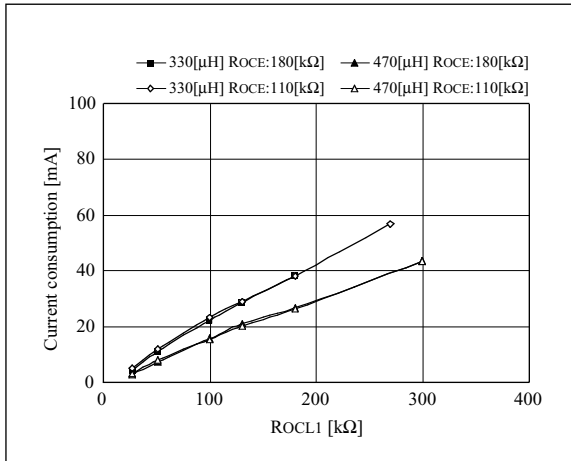

Figure 48. R_{OCL1} – Current consumption

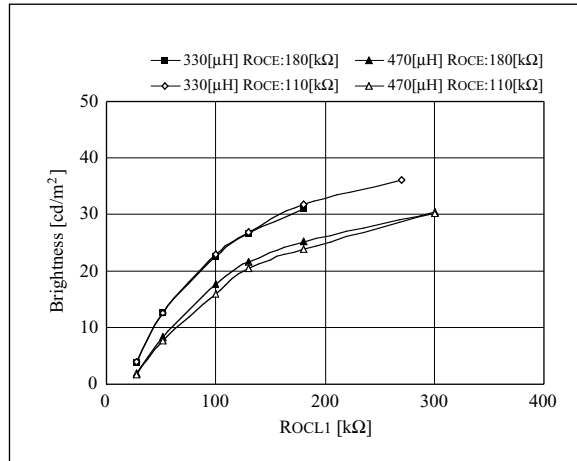

Figure 49. R_{OCL1} – Brightness

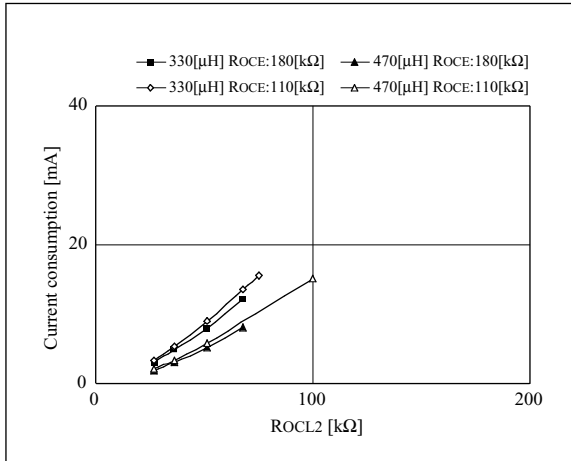

Figure 50. R_{OCL2} – Current consumption

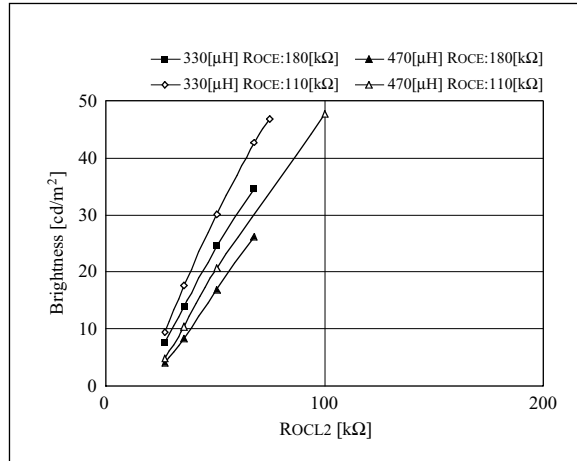

Figure 51. R_{OCL2} – Brightness

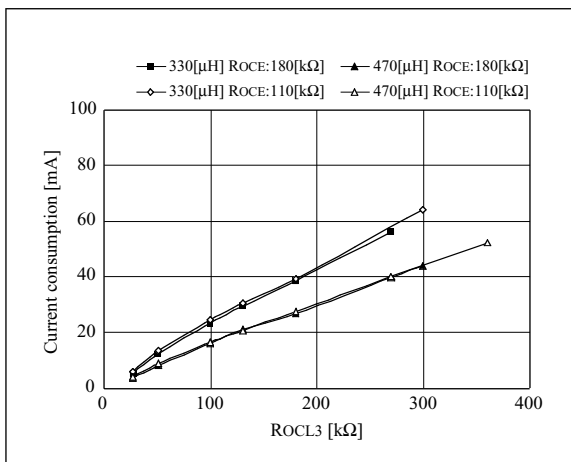

Figure 52. R_{OCL3} – Current consumption

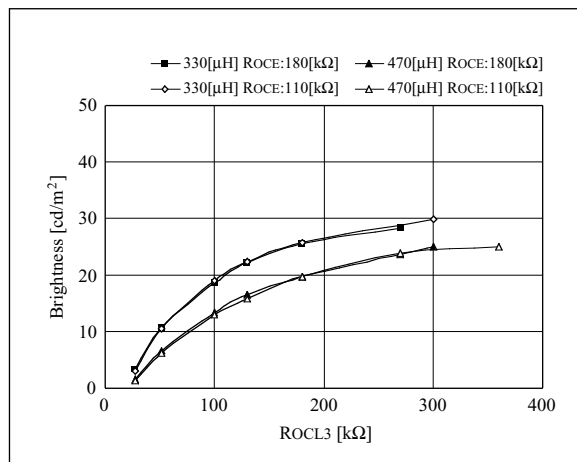

Figure 53. R_{OCL3} – Brightness

$V_{DD} : 3.8 [V]$, $EL1: 15.0 [cm^2]$, $EL2: 4.0 [cm^2]$, Inductor: Murata LQH4N

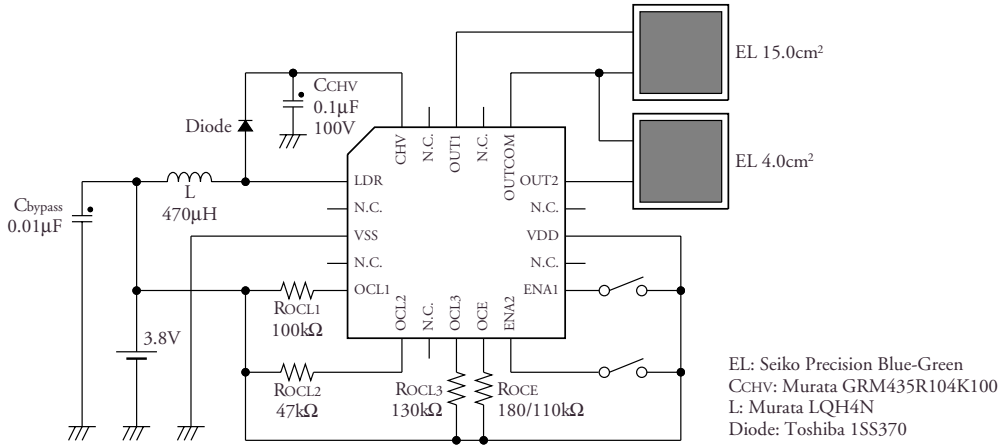

Figure 54. Application circuit

R_{OCL1} typical application values ($EL1: 15.0 [cm^2]$)

$R_{OCE}: 180 [k\Omega]$

Inductance [μH]	$R_{OCL1} [k\Omega]$	Current consumption [mA]	$V_{OUT} [Vp-p]$	Brightness [cd/m^2]
470	100	19.9	184	26.4
330	51	13.8	157	19.8
470	51	9.1	132	13.8

$R_{OCE}: 110 [k\Omega]$

Inductance [μH]	$R_{OCL1} [k\Omega]$	Current consumption [mA]	$V_{OUT} [Vp-p]$	Brightness [cd/m^2]
330	130	36.4	190	40.5
470	100	19.5	151	25.5
470	51	10.0	115	14.2

R_{OCL2} typical application values ($EL2: 4.0 [cm^2]$)

$R_{OCE}: 180 [k\Omega]$

Inductance [μH]	$R_{OCL2} [k\Omega]$	Current consumption [mA]	$V_{OUT} [Vp-p]$	Brightness [cd/m^2]
470	47	5.7	165	23.6
330	30	4.5	140	17.3
470	30	2.8	113	10.7

$R_{OCE}: 110 [k\Omega]$

Inductance [μH]	$R_{OCL2} [k\Omega]$	Current consumption [mA]	$V_{OUT} [Vp-p]$	Brightness [cd/m^2]
330	51	11.2	193	45.1
470	47	5.7	141	25.3
330	27	4.3	119	16.9

R_{OCL3} typical application values ($EL1 + EL2: 19.0 [cm^2]$)

$R_{OCE}: 180 [k\Omega]$

Inductance [μH]	$R_{OCL3} [k\Omega]$	Current consumption [mA]	$V_{OUT} [Vp-p]$	Brightness [cd/m^2]
470	130	26.1	181	25.7
330	51	15.3	147	17.3
470	51	10.1	124	11.6

$R_{OCE}: 110 [k\Omega]$

Inductance [μH]	$R_{OCL3} [k\Omega]$	Current consumption [mA]	$V_{OUT} [Vp-p]$	Brightness [cd/m^2]
330	180	49.5	188	39.8
470	130	26.1	151	25.3
330	51	16.9	129	17.9

Note. The highlighted part in the table indicates the settings in the application circuit above.

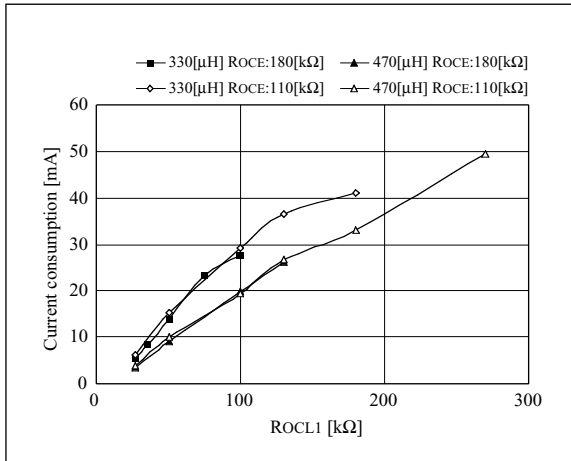

Figure 55. ROCL1 – Current consumption

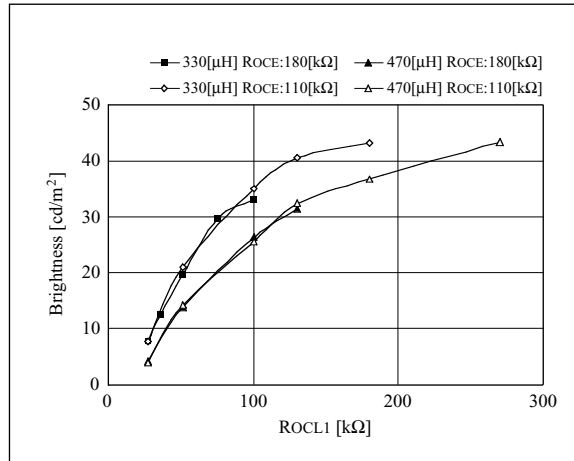

Figure 56. ROCL1 – Brightness

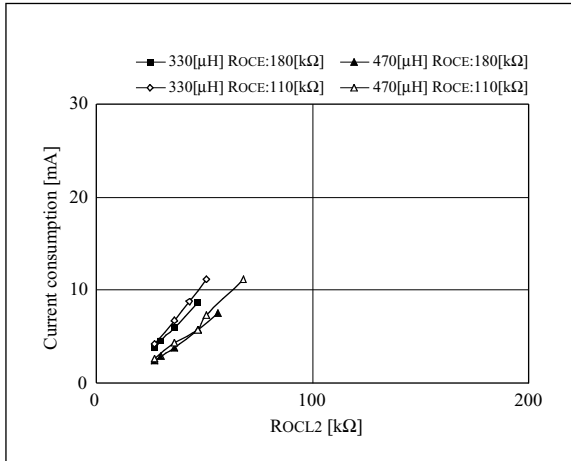

Figure 57. ROCL2 – Current consumption

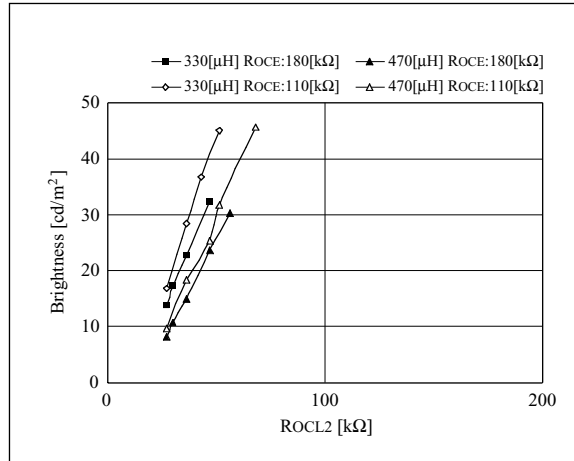

Figure 58. ROCL2 – Brightness

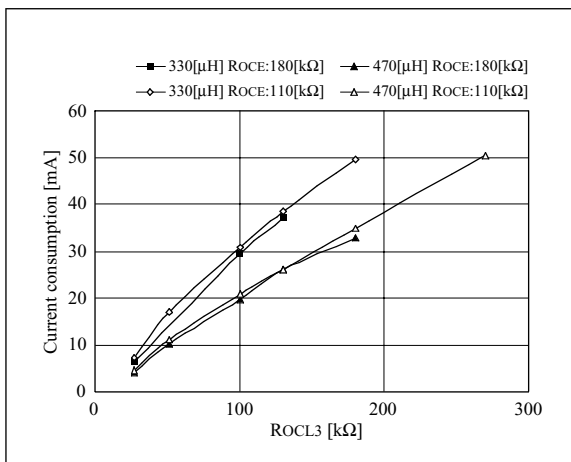

Figure 59. ROCL3 – Current consumption

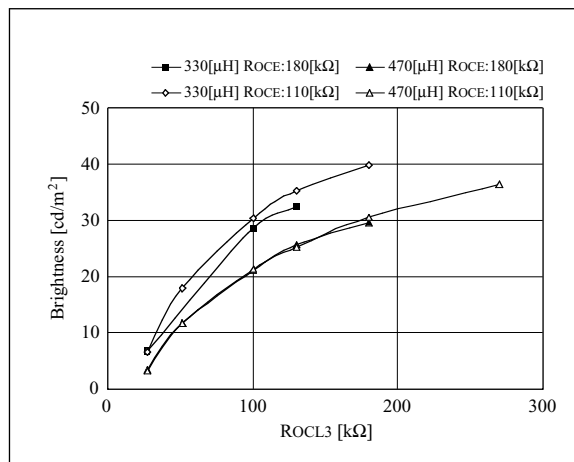

Figure 60. ROCL3 – Brightness

$V_{DD} : 3.0 [V]$, $EL1: 10.0 [cm^2]$, $EL2: 2.0 [cm^2]$, Inductor: River FLC32PL

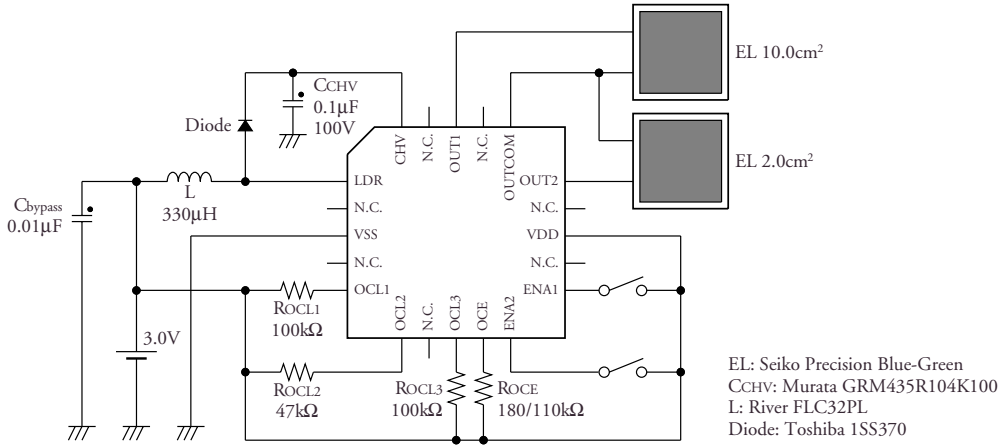

Figure 61. Application circuit

R_{OCL1} typical application values ($EL1: 10.0 [cm^2]$)

$R_{OCE}: 180 [k\Omega]$

Inductance [μH]	$R_{OCL1} [k\Omega]$	Current consumption [mA]	$V_{OUT} [Vp-p]$	Brightness [cd/m^2]
330	100	22.3	192	27.4
470	82	13.2	161	19.8
470	51	6.8	119	10.3

$R_{OCE}: 110 [k\Omega]$

Inductance [μH]	$R_{OCL1} [k\Omega]$	Current consumption [mA]	$V_{OUT} [Vp-p]$	Brightness [cd/m^2]
330	100	23.5	167	29.3
470	82	14.1	142	21.2
470	51	7.5	107	10.8

R_{OCL2} typical application values ($EL2: 2.0 [cm^2]$)

$R_{OCE}: 180 [k\Omega]$

Inductance [μH]	$R_{OCL2} [k\Omega]$	Current consumption [mA]	$V_{OUT} [Vp-p]$	Brightness [cd/m^2]
330	47	7.1	176	27.7
470	47	4.2	144	19.4
470	36	2.9	113	11.1

$R_{OCE}: 110 [k\Omega]$

Inductance [μH]	$R_{OCL2} [k\Omega]$	Current consumption [mA]	$V_{OUT} [Vp-p]$	Brightness [cd/m^2]
330	47	7.6	167	34.9
470	47	4.6	138	24.6
470	36	3.1	109	14.3

R_{OCL3} typical application values ($EL1 + EL2: 12.0 [cm^2]$)

$R_{OCE}: 180 [k\Omega]$

Inductance [μH]	$R_{OCL3} [k\Omega]$	Current consumption [mA]	$V_{OUT} [Vp-p]$	Brightness [cd/m^2]
330	100	24.1	179	26.5
470	82	14.1	151	19.0
470	51	7.5	112	10.0

$R_{OCE}: 110 [k\Omega]$

Inductance [μH]	$R_{OCL3} [k\Omega]$	Current consumption [mA]	$V_{OUT} [Vp-p]$	Brightness [cd/m^2]
330	100	24.6	152	27.7
470	82	13.4	125	18.0
470	51	8.5	102	10.8

Note. The highlighted part in the table indicates the settings in the application circuit above.

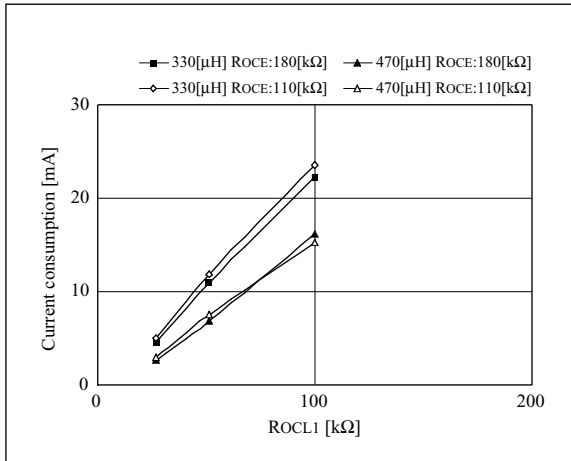

Figure 62. R_{OCL1} – Current consumption

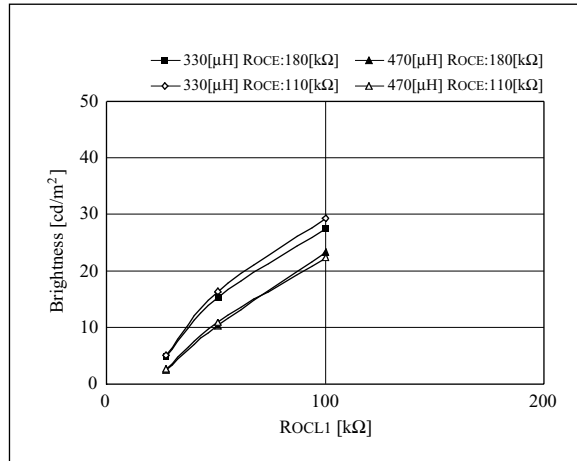

Figure 63. R_{OCL1} – Brightness

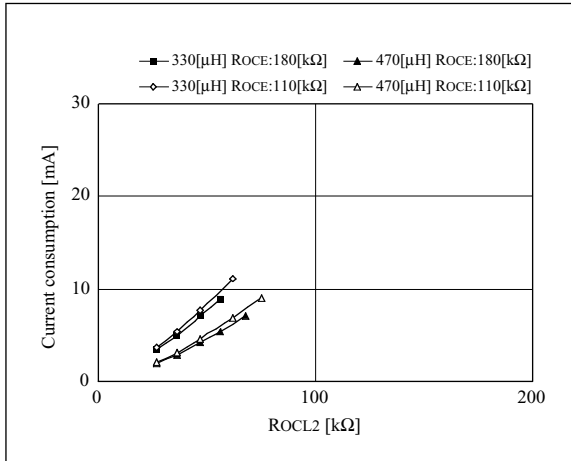

Figure 64. R_{OCL2} – Current consumption

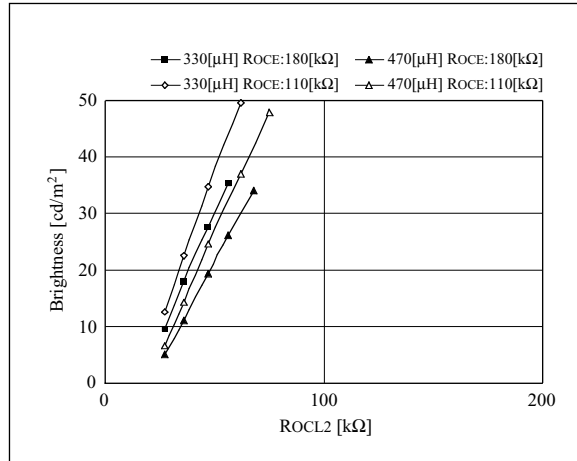

Figure 65. R_{OCL2} – Brightness

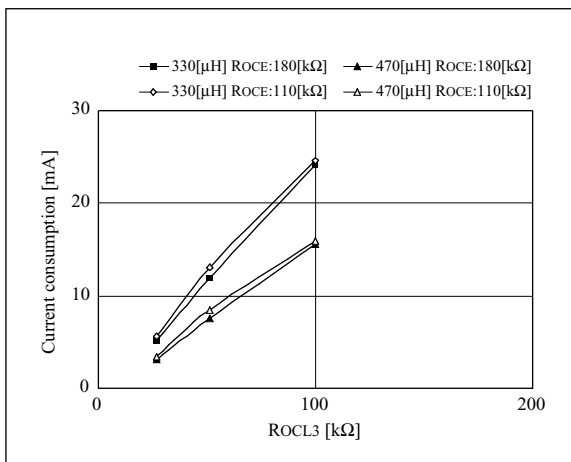

Figure 66. R_{OCL3} – Current consumption

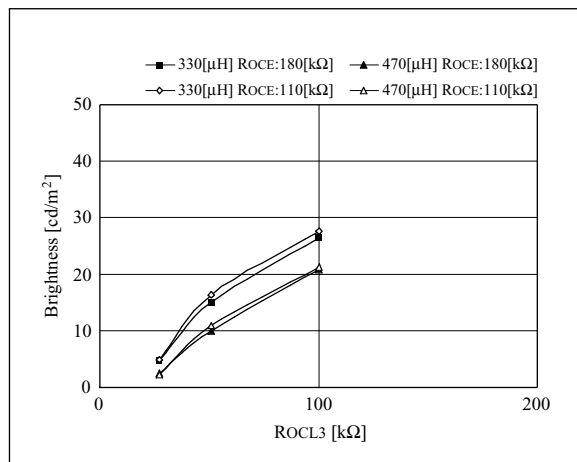

Figure 67. R_{OCL3} – Brightness

$V_{DD} : 3.8 [V]$, $EL1: 10.0 [cm^2]$, $EL2: 2.0 [cm^2]$, Inductor: River FLC32PL

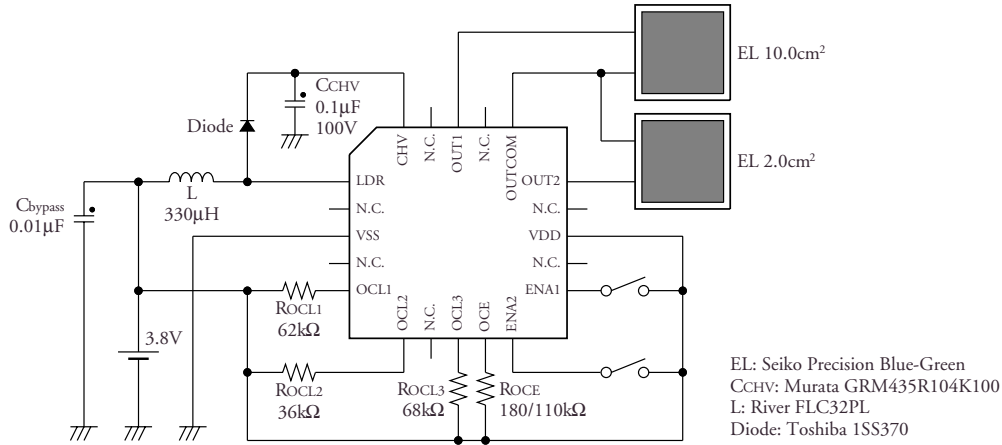

Figure 68. Application circuit

R_{OCL1} typical application values ($EL1: 10.0 [cm^2]$)

$R_{OCE}: 180 [k\Omega]$

Inductance [μH]	$R_{OCL1} [k\Omega]$	Current consumption [mA]	$V_{OUT} [Vp-p]$	Brightness [cd/m^2]
330	62	17.7	198	29.1
470	68	12.9	179	24.8
470	47	7.8	141	15.5

$R_{OCE}: 110 [k\Omega]$

Inductance [μH]	$R_{OCL1} [k\Omega]$	Current consumption [mA]	$V_{OUT} [Vp-p]$	Brightness [cd/m^2]
330	62	19.5	176	32.1
470	51	9.5	132	18.7
470	43	7.6	119	14.6

R_{OCL2} typical application values ($EL2: 2.0 [cm^2]$)

$R_{OCE}: 180 [k\Omega]$

Inductance [μH]	$R_{OCL2} [k\Omega]$	Current consumption [mA]	$V_{OUT} [Vp-p]$	Brightness [cd/m^2]
330	36	6.1	179	28.4
470	36	3.6	146	19.5
470	27	2.4	110	10.5

$R_{OCE}: 110 [k\Omega]$

Inductance [μH]	$R_{OCL2} [k\Omega]$	Current consumption [mA]	$V_{OUT} [Vp-p]$	Brightness [cd/m^2]
330	36	6.6	171	36.7
470	36	3.9	140	24.2
470	27	2.6	106	13.1

R_{OCL3} typical application values ($EL1 + EL2: 12.0 [cm^2]$)

$R_{OCE}: 180 [k\Omega]$

Inductance [μH]	$R_{OCL3} [k\Omega]$	Current consumption [mA]	$V_{OUT} [Vp-p]$	Brightness [cd/m^2]
330	68	21.1	197	30.9
470	68	13.7	167	23.3
470	47	8.4	132	14.6

$R_{OCE}: 110 [k\Omega]$

Inductance [μH]	$R_{OCL3} [k\Omega]$	Current consumption [mA]	$V_{OUT} [Vp-p]$	Brightness [cd/m^2]
330	68	21.3	168	32.4
470	68	14.8	147	24.9
470	47	9.1	117	15.6

Note. The highlighted part in the table indicates the settings in the application circuit above.

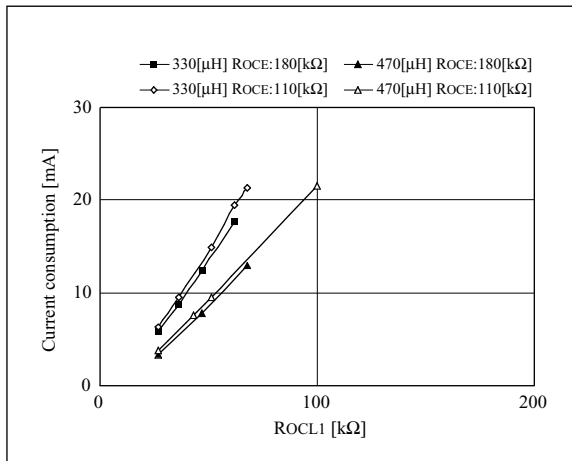

Figure 69. ROCL1 – Current consumption

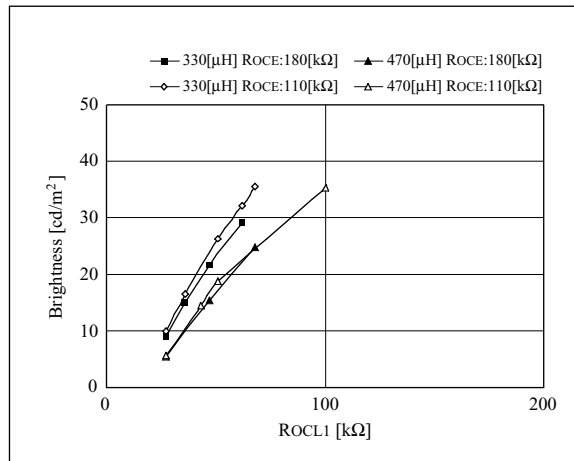

Figure 70. ROCL1 – Brightness

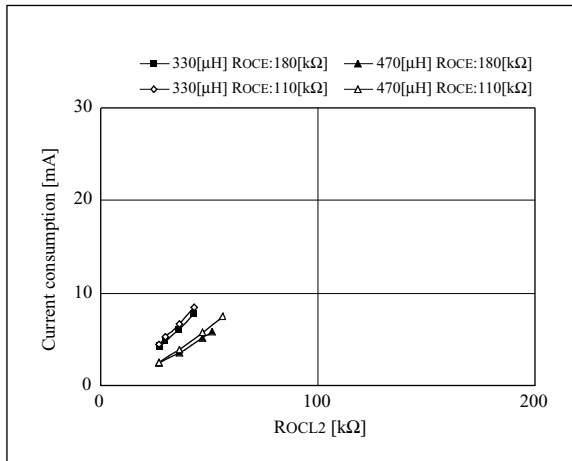

Figure 71. ROCL2 – Current consumption

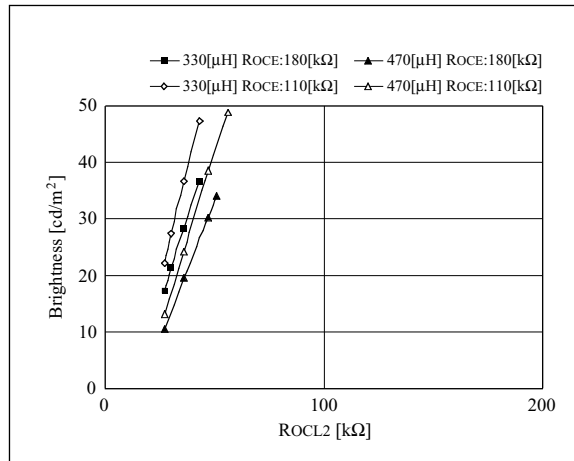

Figure 72. ROCL2 – Brightness

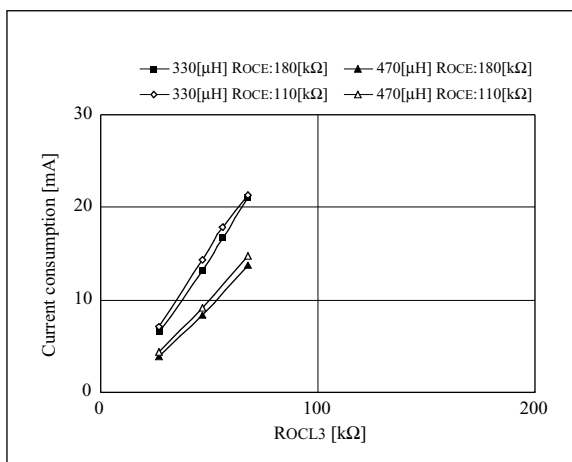

Figure 73. ROCL3 – Current consumption

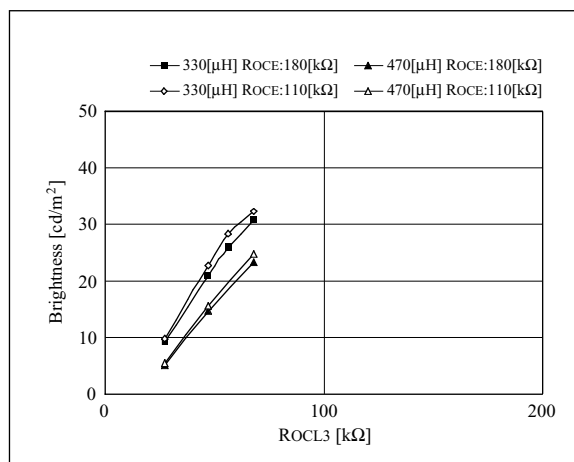

Figure 74. ROCL3 – Brightness

CONSIDERATIONS SEVERAL TYPES of NOISE

This section considers several types of noise subdivided into audible noise, electromagnetic noise, and

supply wraparound noise. Please refer to datasheet for details.

Audible Noise

Audible noises (or ringing) are mainly caused by the capacitor (C_{CHV}) and the EL panel itself. In addition to the noise from these sources is resonant noise

from the case, PCB and other components (especially the capacitor).

Capacitor (C_{CHV})

Electrical Considerations

The capacitor (C_{CHV}) connection is very susceptible to ringing noise generation due to voltage fluctuations caused by the EL driver. Generally speaking, high-withstand voltage type capacitors generate less ringing noise.

Relatively high ringing output ceramic chip capacitors can be replaced with low ringing output mylar chip capacitors, and further benefit can be obtained if mounting and cost aspects allow.

If the range of devices available for selection is small, electrically reducing the effect of voltage fluctuations will reduce the ringing noise generated. Specifically, R_{CHV} should be inserted (10 to 20k Ω) and R_{OUT} should be increased (50k Ω max).

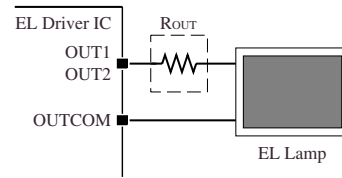
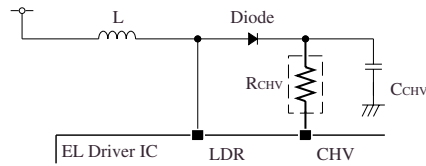

The reduction in C_{CHV} ringing noise is the same in both cases, but making R_{OUT} larger does have an unfavorable result on efficiency. Inserting R_{CHV} , however, is an effective way of reducing only the C_{CHV} ringing noise.

Physical Considerations

The capacitor, which generates the ringing noise, should be mounted as close as possible to the support struts to reduce PCB and case resonant noise. If possible, a more sturdy PCB construction should also be considered.

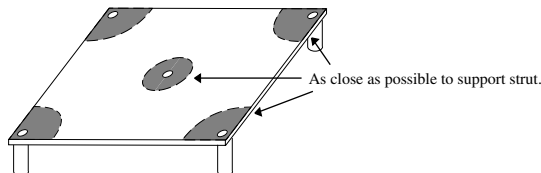

Furthermore, if the chip capacitor is mounted laying on its side, then the contact area with the PCB is minimized which will also help reduce noise.

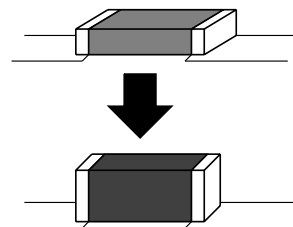

EL Lamp

The EL display has a piezoelectric characteristic, which may generate output noise. There is generally 2 sources that can cause noise, the potential differ-

Electrical Considerations

The EL lamp noise can be reduced by inserting R_{OUT} ($50k\Omega$ max) which causes the output waveform to be modified such that the high-frequency components are reduced (see page 5, Output Waveform).

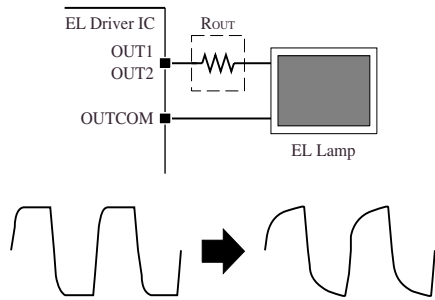

A shielded (3-pin type) EL display is effective in preventing noise between the EL display and other components. Also, the piezoelectric effect can be prevented by avoiding potentials on plane surfaces, such as VDD or ground planes.

Electromagnetic Noise

In addition to the EL lamp acting as an antenna, the driver circuit with its high-voltage booster circuit that uses an inductor and capacitor generates radi-

Wiring and Layout

In particular, all circuit wiring between the high-voltage inductor, capacitor (C_{CHV}), diode and EL driver LDR pin should be as thick and as short as possible.

EL Lamp

The EL lamp can act as an antenna and emit noise, so, where possible, a shielded EL lamp should be used to reduce the emitted noise.

Components easily affected by induced noise should have their wiring located well away from the EL lamp wiring to prevent induced noise.

Inductor

The inductor is a source of electromagnetic noise, so peripheral components should have high impedance and wiring layout to avoid induced noise. If possible,

ence between the EL display electrodes and the potential difference between the EL display and other components, such as a ground plane.

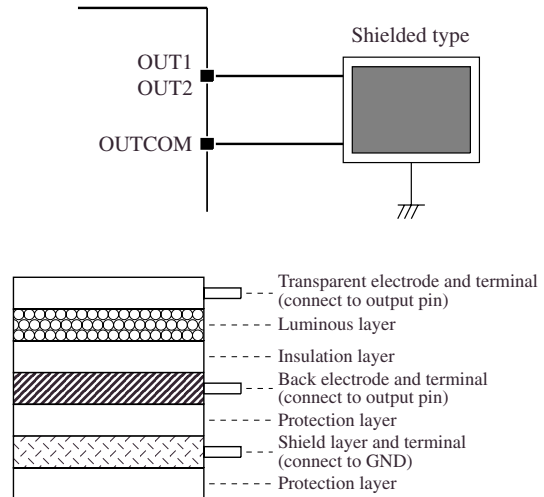

Construction of shielded EL

Physical Considerations

The most effective means of protecting the EL display physically is by using non-woven fabric cloth or PET (plastic) film for absorbing and limiting vibration.

ated noise caused by the current and capacitive noise induced by the voltage.

Also, the wiring between the outputs (OUT1, OUT2, OUTCOM) and EL lamp should be as thick and as short as possible.

Resistor R_{OUT} can be inserted to reduce the high-frequency component of the EL driver waveform.

the inductor should be a closed-magnetic type, such as a toroid.

Supply Wraparound Noise

In the booster circuit, the inductor drive transistor switches ON/OFF, generating a sawtooth waveform (see page 3, Figure 8) whose pulse travels from the EL driver LDR pin through to the VSS pin, thereby forming a return path back to the supply. Accordingly, a bypass capacitor (C_{Bypass}) should be connected, adjacent to the inductor, between the

inductor and the EL driver VSS pin to absorb the pulses.

Note that the LDR pin voltage is boosted by the inductor and can have amplitudes up to 100V.

The supply system connected to the inductor should also be separated as much as possible from the supply lines for other components.

Notice to Application Circuit

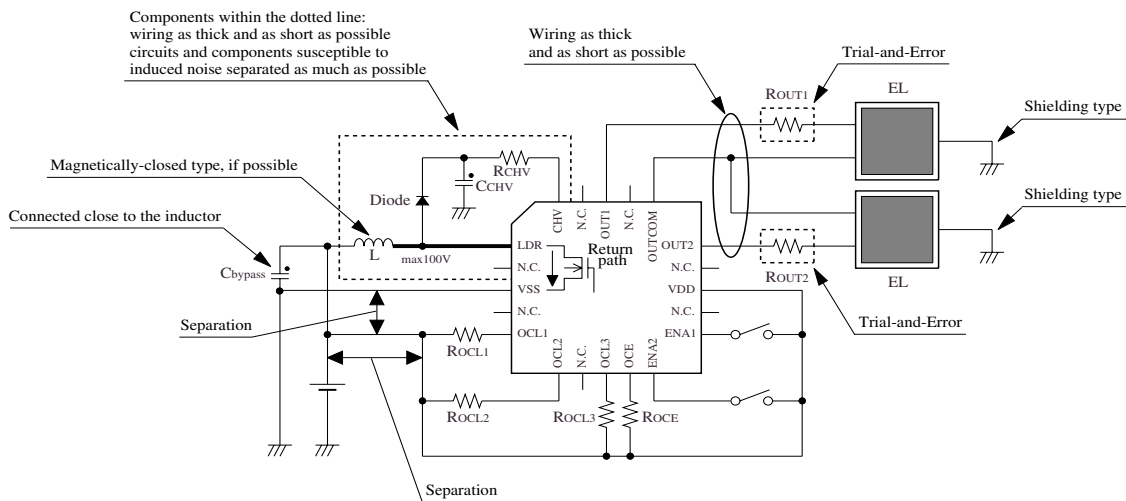

Component	Description	Value
Inductor	Booster inductor. The current flowing through the inductor is a triangular waveform, and care should be taken so that the peak current does not exceed the maximum current. An inductor with low resistance will help reduce loss.	0.15 to 0.68mH
Diode	A fast recovery diode with short reverse recovery time at peak reverse voltages exceeding 100V.	
C_{CHV}	Capacitor rated at $\geq 100V$	0.1 μ F (100V)
R_{OCL1} to R_{OCL3}	Inductor drive frequency control resistor	51 to 1000k Ω
R_{OCE}	EL drive frequency control resistor	51 to 1000k Ω
C_{Bypass}	Supply bypass capacitor (noise cut)	0.01 μ F
R_{CHV}	Optional. Reduces the output waveform rise time, and reduces noise.	10 to 20k Ω
R_{OUT}	Optional. Reduces noise emitted by the EL element.	$\leq 50k\Omega$

EQUIVALENT CIRCUIT

The EL display driver must not be operated without an output load as this may damage the IC. For testing purposes, including testing during the manufacturing process, where the IC cannot be connected to an EL display, the following equivalent circuit should be used.

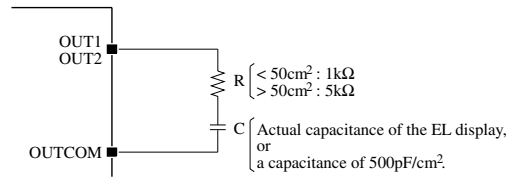

FOOTPRINT

The optimum footprint varies depending on the board material, soldering paste, soldering method, and equipment accuracy, all of which need to be considered to meet design specifications.

(Unit: mm)

Package	HE	HD	e	b3	l1	l2
QFN-20	4.2	4.2	0.5	0.30 ± 0.05	0.20 ± 0.05	0.70 ± 0.05

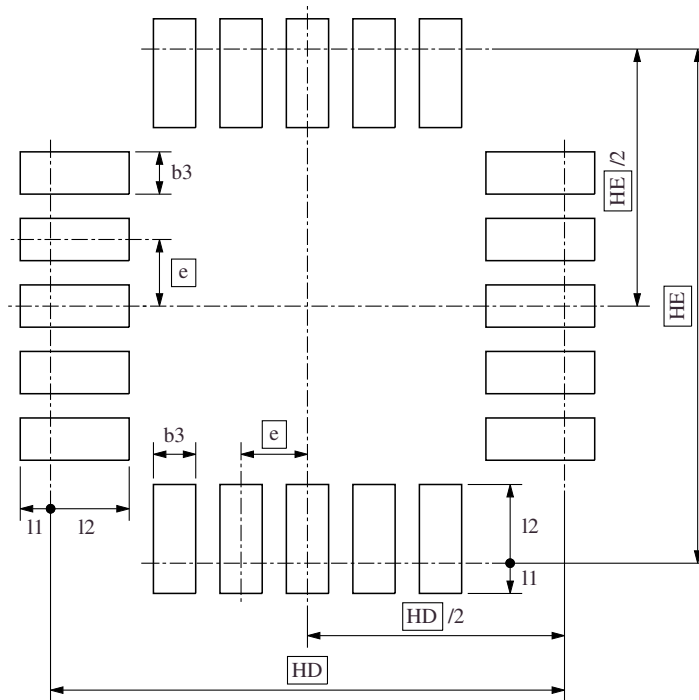

NIPPON PRECISION CIRCUITS INC. reserves the right to make changes to the products described in this document in order to improve the design or performance and to supply the best possible products. Nippon Precision Circuits Inc. assumes no responsibility for the use of any circuits shown in this document, conveys no license under any patent or other rights, and makes no claim that the circuits are free from patent infringement. Applications for any devices shown in this document are for illustration only and Nippon Precision Circuits Inc. makes no claim or warranty that such applications will be suitable for the use specified without further testing or modification. The products described in this document are not intended to use for the apparatus which influence human lives due to the failure or malfunction of the products. Customers are requested to comply with applicable laws and regulations in effect now and hereinafter, including compliance with export controls on the distribution or dissemination of the products. Customers shall not export, directly or indirectly, any products without first obtaining required licenses and approvals from appropriate government agencies.



NIPPON PRECISION CIRCUITS INC.

4-3, Fukuzumi 2-chome, Koto-ku,
Tokyo 135-8430, Japan
Telephone: +81-3-3642-6661
Facsimile: +81-3-3642-6698
<http://www.npc.co.jp/>
Email: sales@npc.co.jp

NK0006BE 2001.12