

### OVERVIEW

The SM8144B is a transformer-less electroluminescent (EL) driver IC, capable of driving displays up to 70 cm<sup>2</sup> in size. It is a high-efficiency driver that features revised inductor switching transistor ON resistance and output circuit configuration to reduce loss, all in a compact package. A microcontroller interface pin (ENA) is provided, which can be used to control the EL driver ON/OFF function. The device is available in 8-pin VSOP packages.

### FEATURES

- Dedicated EL driver
- 1.6 to 5.5V supply voltage
- 100mA maximum operating current  
( $V_{DD} = 3.0V$ ,  $T_a \leq 70^\circ C$ )
- 3.5Ω typical output resistance
- 200Vp-p maximum EL driver voltage\*
- 31 to 1500Hz EL drive frequency range\*
- High voltage CMOS Process
- 8-pin VSOP plastic package

\*: Adjustable with external resistance.

### APPLICATIONS

- Hand held PC, Palm size PC
- Mobile IT equipment
- White EL

### ORDERING INFORMATION

Device	Package
SM8144BV	8-pin VSOP

### PINOUT

(Top view)

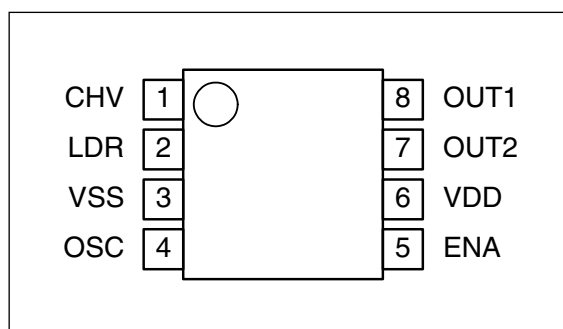

### PACKAGE DIMENSIONS

(Unit : mm)

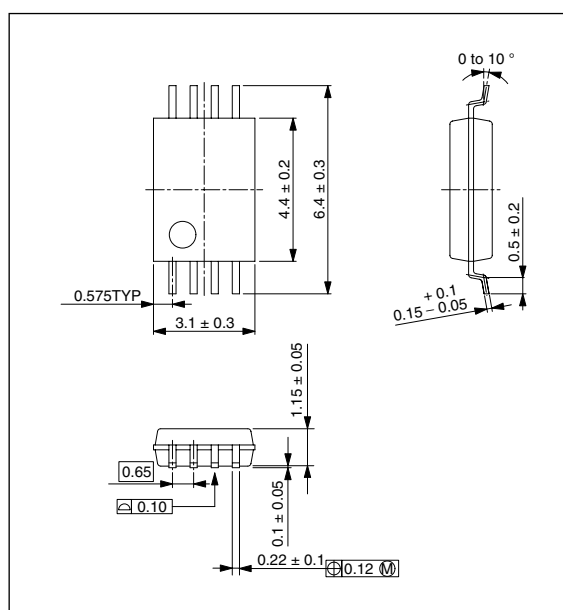

**BLOCK DIAGRAM**

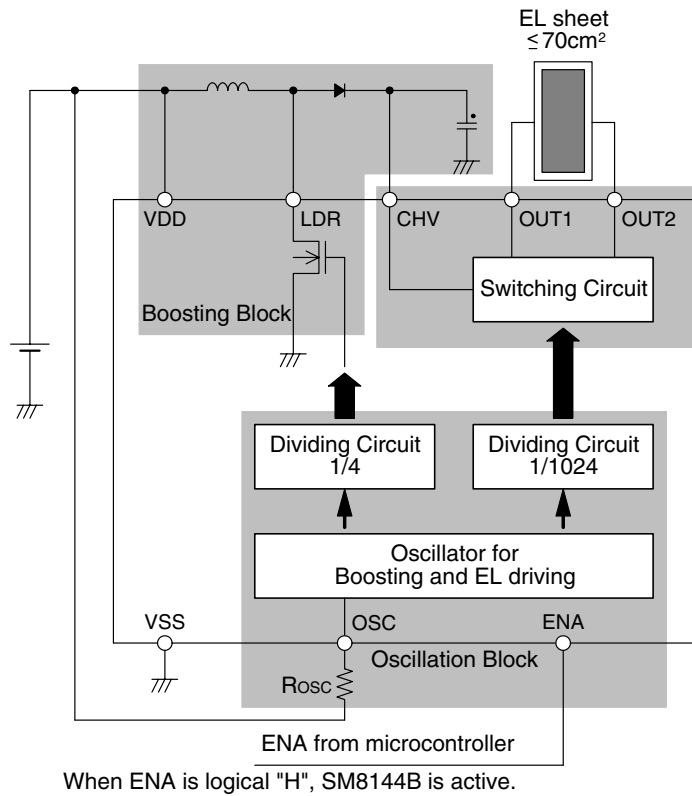

**PIN DESCRIPTION**

Pin number	Name	I/O	Function
1	CHV	I	High-voltage DC input
2	LDR	O	Booster inductor driver output
3	VSS	-	Ground
4	OSC	I	Inductor and EL driver oscillator (oscillator frequency determined by external resistor)
5	ENA	Ip <sup>1</sup>	Enable input (HIGH: enable, LOW: disable)
6	VDD	-	Supply
7	OUT2	O	Output 2
8	OUT1	O	Output 1

1. Built-in pull-down resistor.

## SPECIFICATIONS

### Absolute Maximum Ratings

Parameter	Symbol	Condition	Rating	Unit
Supply voltage range	$V_{DD}$		- 0.3 to 7.0	V
Input voltage range	$V_{IN}$	All Input pins	$V_{SS} - 0.3$ to $V_{DD} + 0.3$	V
Output voltage	$V_{CHV}$	CHV pin	0.5 to 120	V
	$V_{LDR}$	LDR pin	0.5 to 120	V
	$V_{OUT1/2}$	OUT1, OUT2 pin	0.5 to 120	V
Power dissipation	$P_D$	$T_a \leq 70^\circ\text{C}$	140	mW
		$T_a \leq 85^\circ\text{C}$	100	mW
Storage temperature range	$T_{STG}$		- 55 to 125	$^\circ\text{C}$

### Recommended Operating Conditions

Parameter	Symbol	Condition	Rating			Unit
			min	typ	max	
Supply voltage range	$V_{DD2}$		1.6	3.0	5.5	V
Operating temperature	$T_{OPR}$		- 40	-	85	$^\circ\text{C}$
Operating current <sup>1</sup>	$I_{DD2}$	Including inductor current, $V_{DD} = 3.0\text{V}$ , $T_a \leq 70^\circ\text{C}$	-	-	100	mA
		Including inductor current, $V_{DD} = 5.0\text{V}$ , $T_a \leq 70^\circ\text{C}$	-	-	60	mA
		Including inductor current, $V_{DD} = 3.0\text{V}$ , $T_a \leq 85^\circ\text{C}$	-	-	70	mA
		Including inductor current, $V_{DD} = 5.0\text{V}$ , $T_a \leq 85^\circ\text{C}$	-	-	42	mA
Inductance	$L_{LDR}$	$f_{LDR} = 64\text{kHz}$	-	0.47	-	mH

1. Max value is as same as Absolute Maximum Ratings.

## Electrical Characteristics

$V_{DD} = 3.0V$ ,  $T_a = 25^\circ C$  unless otherwise noted.

Parameter	Symbol	Condition	Rating			Unit
			min	typ	max	
Supply voltage	$V_{DD}$		1.6	3.0	5.5	V
CHV output voltage	$V_{CHV}$		0.5	–	100	V
OUT1, OUT2 HIGH-level output voltage	$V_{OUTH}$		–	–	100	V
OUT1, OUT2 LOW-level output voltage	$V_{OUTL}$		–	–	0.5	V
LDR output resistance	$R_{LDR}$	$I_{LDR} = 50mA$	–	3.5	5.25	$\Omega$
OSC oscillator frequency	$f_{OSC1}$	$R_{OSC} = 180k\Omega$	205	256	307	kHz
OSC oscillator frequency range	$f_{OSC2}$		32	–	1536	
OUT1, OUT2 output frequency	$f_{OUT1}$	$R_{OSC} = 180k\Omega$	200	250	300	Hz
OUT1, OUT2 output frequency range	$f_{OUT2}$		31	–	1500	
LDR inductance driver frequency	$f_{LDR1}$	$R_{OSC} = 180k\Omega$	51	64	77	kHz
LDR inductance driver frequency range	$f_{LDR2}$		8	–	384	
ENA HIGH-level input voltage	$V_{ENAH}$	ENA = HIGH, $V_{DD} = 1.6$ to $5.5V$	$V_{DD} - 0.5$	–	$V_{DD} + 0.3$	V
ENA LOW-level input voltage	$V_{ENAL}$	ENA = LOW, $V_{DD} = 1.6$ to $5.5V$	$V_{SS} - 0.3$	–	$V_{SS} + 0.5$	
ENA input current	$I_{ENAH}$	$V_{ENAH} = V_{DD} = 3.0V$	2.0	4.0	6.0	$\mu A$
ENA rise time <sup>1</sup>	$t_{ENA}$		–	–	100	$\mu s$
Operating current	$I_{DD1}$	Excluding inductor current	–	–	1.0	mA
Stand-by current	$I_{STB}$	ENA = LOW	–	–	1.0	$\mu A$

1.

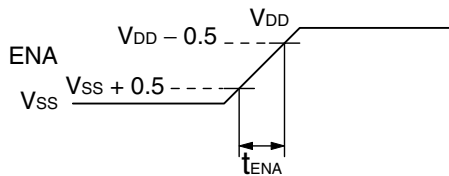

## TYPICAL APPLICATIONS

- EL sheet size: 20 to 30cm<sup>2</sup>, Current consumption: 20mA

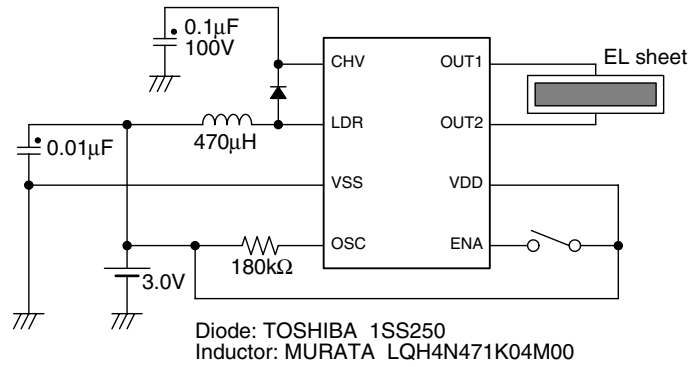

- EL sheet size: 30 to 50cm<sup>2</sup>, Current consumption: 40mA

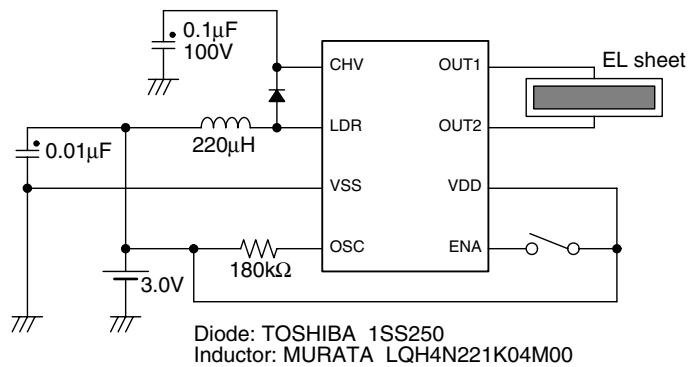

- EL sheet size: 50 to 100cm<sup>2</sup>, Current consumption: 80mA

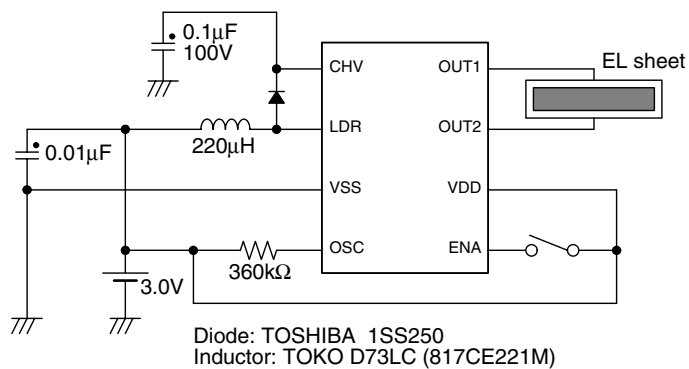

Note: Do not operate the SM8144B with the EL sheet NOT connected (no load to OUT1/OUT2) since the IC will be damaged.

Please pay your attention to the following points at time of using the products shown in this document.

The products shown in this document (hereinafter "Products") are not intended to be used for the apparatus that exerts harmful influence on human lives due to the defects, failure or malfunction of the Products. Customers are requested to obtain prior written agreement for such use from SEIKO NPC CORPORATION (hereinafter "NPC"). Customers shall be solely responsible for, and indemnify and hold NPC free and harmless from, any and all claims, damages, losses, expenses or lawsuits, due to such use without such agreement. NPC reserves the right to change the specifications of the Products in order to improve the characteristic or reliability thereof. NPC makes no claim or warranty that the contents described in this document dose not infringe any intellectual property right or other similar right owned by third parties. Therefore, NPC shall not be responsible for such problems, even if the use is in accordance with the descriptions provided in this document. Any descriptions including applications, circuits, and the parameters of the Products in this document are for reference to use the Products, and shall not be guaranteed free from defect, inapplicability to the design for the mass-production products without further testing or modification. Customers are requested not to export or re-export, directly or indirectly, the Products to any country or any entity not in compliance with or in violation of the national export administration laws, treaties, orders and regulations. Customers are requested appropriately take steps to obtain required permissions or approvals from appropriate government agencies.

The logo for SEIKO NPC CORPORATION, consisting of the letters 'NPC' in a bold, black, sans-serif font.

**SEIKO NPC CORPORATION**

15-6, Nihombashi-kabutocho, Chuo-ku,  
Tokyo 103-0026, Japan  
Telephone: +81-3-6667-6601  
Facsimile: +81-3-6667-6611  
<http://www.npc.co.jp/>  
Email: [sales@npc.co.jp](mailto:sales@npc.co.jp)

NC0006BE 2006.04