

Overview

The SM5902 is a compression and non compression type shock-proof memory controller LSI for compact disc players. The compression level can be set in 4 levels, and external memory can be

selected from 4 options (1M, 4M, 4M× 2, 16M). Digital attenuator, soft mute and related functions are also incorporated. It operates from a 2.4 to 5.5 V wide supply voltage range.

Features

- 2-channel processing
- Serial data input
 - 2s complement, 16-bit/MSB first, right-justified format
 - Wide capture function (up to 3 × speed input rate)
- System clock input
 - 384fs (16.9344 MHz)
- Shock-proof memory controller
 - ADPCM compression method
 - 4-level compression mode selectable
 - 4-bit compression mode 2.78 s/Mbit
 - 5-bit compression mode 2.22 s/Mbit
 - 6-bit compression mode 1.85 s/Mbit
 - Full-bit non compression mode 0.74 s/Mbit
 - 4 external DRAM configurations selectable
 - 1 × 16M DRAM (4M × 4 bits, refresh cycle = 2048 cycle)
 - 1 × or 2 × 4M DRAM (1M × 4 bits)
 - 1 × 1M DRAM (256k × 4 bits)
 - DRAM at 5V operation is usable for Low-voltage operation
- Compression mode selectable
- Microcontroller interface
 - Serial command write and status read-out
 - Data residual detector:
 - 15-bit operation, 16-bit output
 - Digital attenuator
 - 8-bit setting
 - Soft attenuator function
 - Noiseless attenuation-level switching (256- step switching in 23 ms max.)
 - Soft mute function
 - Mute ON in 23 ms max.
 - Direct return after soft mute release
 - Forced mute
- Extension I/O
 - Microcontroller interface for external control using 5 extension I/O pins
- +2.4 to +5.5 V wide operating voltage range
- Schmitt inputs
 - All input pins (including I/O pins) except CLK (system clock)
- Reset signal noise elimination
 - Approximately 3.8 μs or longer (65 system clock pulses) continuous LOW-level reset
- Digital audio interface (DIT)
- 44-pin QFP package (0.8 mm pin pitch)

Ordering Information

SM5902AF 44pin QFP

SM5902AF

Package dimensions (Unit: mm)

44-pin QFP 1

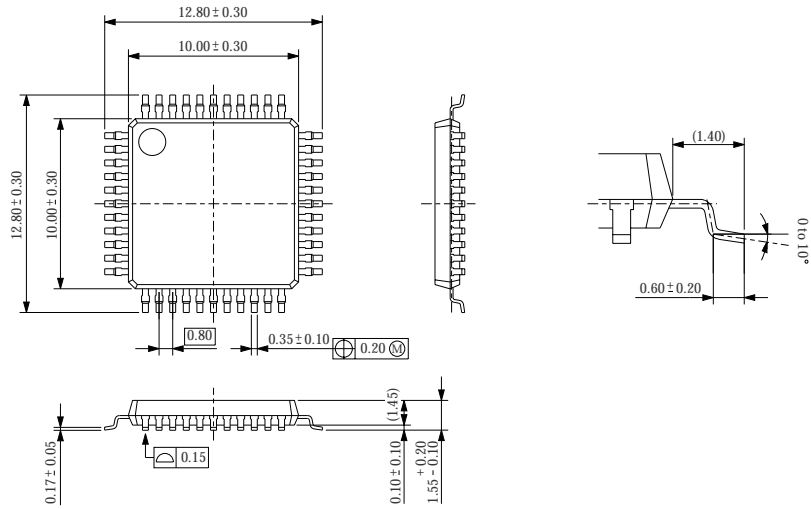

44-pin QFP 2

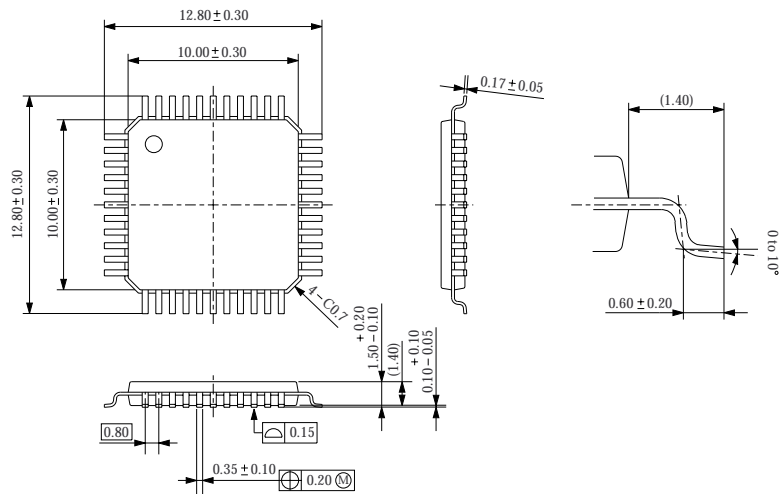

Pinout (Top View)

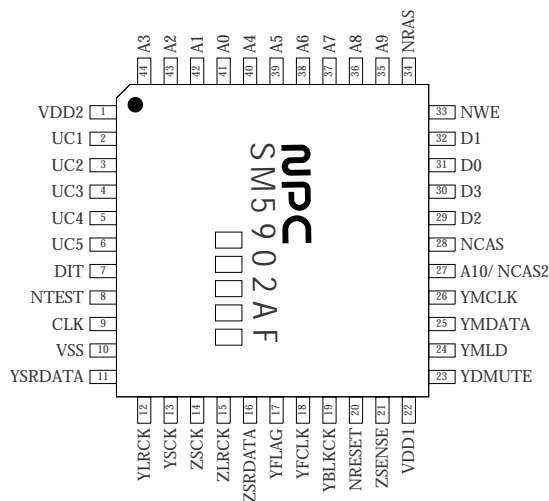

SM5902AF

Pin description

Pin number	Pin name	I/O	Function	Setting	
				H	L
1	VDD2	-	VDD supply pin		
2	UC1	Ip/O	Microcontroller interface extension I/O 1		
3	UC2	Ip/O	Microcontroller interface extension I/O 2		
4	UC3	Ip/O	Microcontroller interface extension I/O 3		
5	UC4	Ip/O	Microcontroller interface extension I/O 4		
6	UC5	Ip/O	Microcontroller interface extension I/O 5		
7	DIT	O	Digital audio interface		
8	NTEST	Ip	Test pin		Test
9	CLK	I	16.9344 MHz clock input		
10	VSS	-	Ground		
11	YSRDATA	I	Audio serial input data		
12	YLRCK	I	Audio serial input LR clock	Left channel	Right channel
13	YSCK	I	Audio serial input bit clock		
14	ZSCK	O	Audio serial output bit clock		
15	ZLRCK	O	Audio serial output LR clock	Left channel	Right channel
16	ZSRDATA	O	Audio serial output data		
17	YFLAG	I	Signal processor IC RAM overflow flag		Overflow
18	YFCLK	I	Crystal-controlled frame clock		
19	YBLKCK	I	Subcode block clock signal		
20	NRESET	I	System reset pin		Reset
21	ZSENSE	O	Microcontroller interface status output		
22	VDD1	-	VDD supply pin		
23	YDMUTE	I	Forced mute pin	Mute	
24	YMLD	I	Microcontroller interface latch clock		
25	YMDATA	I	Microcontroller interface serial data		
26	YMCLK	I	Microcontroller interface shift clock		
27	A10 (NCAS2)	O	DRAM address 10		
		O	DRAM2 $\overline{\text{CAS}}$ control (with 2 DRAMs)		
28	NCAS	O	DRAM $\overline{\text{CAS}}$ control		
29	D2	I/O	DRAM data input/output 2		
30	D3	I/O	DRAM data input/output 3		
31	D0	I/O	DRAM data input/output 0		
32	D1	I/O	DRAM data input/output 1		
33	NWE	O	DRAM $\overline{\text{WE}}$ control		
34	NRAS	O	DRAM $\overline{\text{RAS}}$ control		
35	A9	O	DRAM address 9		
36	A8	O	DRAM address 8		
37	A7	O	DRAM address 7		
38	A6	O	DRAM address 6		
39	A5	O	DRAM address 5		
40	A4	O	DRAM address 4		
41	A0	O	DRAM address 0		
42	A1	O	DRAM address 1		
43	A2	O	DRAM address 2		
44	A3	O	DRAM address 3		

Ip : Input pin with pull-up resistor Ip/O : Input/Output pin (With pull-up resistor when in input mode)

Absolute maximum ratings

($V_{SS} = 0V$, V_{DD1} , V_{DD2} pin voltage = V_{DD})

Parameter	Symbol	Rating	Unit
Supply voltage	V_{DD}	- 0.3 to 7.0	V
Input voltage	V_I	$V_{SS} - 0.3$ to $V_{DD} + 0.3$	V
Storage temperature	T_{STG}	- 55 to 125	°C
Power dissipation	P_D	350	mW
Soldering temperature	T_{SLD}	255	°C
Soldering time	t_{SLD}	10	sec

(*1) Refer to pin summary on the next page.

Note. Values also apply for supply inrush and switch-off.

Electrical characteristics

Recommended operating conditions

($V_{SS} = 0V$, V_{DD1} , V_{DD2} pin voltage = V_{DD})

Parameter	Symbol	Rating	Unit
Supply voltage	V_{DD}	2.4 to 5.5	V
Operating temperature	T_{OPR}	- 40 to 85	°C

DC characteristics

Standard voltage: ($V_{DD1} = V_{DD2} = 4.5$ to 5.5 V, $V_{SS} = 0$ V, $T_a = - 40$ to 85 °C)

Parameter	Pin	Symbol		Condition	Rating			Unit
					Min	Typ	Max	
Current consumption	VDD	I_{DD}		(*A)SHPRF ON		13.5	25.0	mA
				(*A)Through mode		5.0	7.5	mA
Input voltage	CLK	H level	V_{IH1}		$0.7V_{DD}$			V
		L level	V_{IL1}			$0.3V_{DD}$		V
			V_{INAC}	AC coupling	0.3			V_{P-P}
	(*2,3,4)	H level	V_{IH2}		$0.7V_{DD}$			V
		L level	V_{IL2}				$0.3V_{DD}$	V
	(*5)	H level	V_{IH3}		$0.6V_{DD}$			V
L level		V_{IL3}				$0.2V_{DD}$	V	
Output voltage	(*4,6)	H level	V_{OH1}	$I_{OH} = - 0.5$ mA	$V_{DD} - 0.4$			V
		L level	V_{OL1}	$I_{OL} = 0.5$ mA			0.4	V
	(*5,7)	H level	V_{OH2}	$I_{OH} = - 0.5$ mA	$V_{DD} - 0.4$			V
		L level	V_{OL2}	$I_{OL} = 0.5$ mA			0.4	V
Input current	CLK	I_{IH1}		$V_{IN} = V_{DD}$	40	95	190	μA
		I_{IL1}		$V_{IN} = 0V$	40	95	190	μA
	(*3,4)	I_{IL2}		$V_{IN} = 0V$	6	12	25	μA
Input leakage current	(*2,3,4,5)	I_{LH}		$V_{IN} = V_{DD}$			1.0	μA
	(*2,5)	I_{LL}		$V_{IN} = 0V$			1.0	μA

(*A) $V_{DD1} = V_{DD2} = 5$ V, CLK input frequency $f_{XT1} = 384fs = 16.9344$ MHz, all outputs unloaded,
SHPRF: Shock-proof,
typical values are for $V_{DD1} = V_{DD2} = 5$ V.

SM5902AF

Low-voltage:(VDD1 = VDD2 = 2.4 to 4.5 V, VSS = 0 V, Ta = - 20 to 70 °C)

Parameter	Pin	Symbol		Condition	Rating			Unit
					Min	Typ	Max	
Current consumption	VDD	IDD		(*B)SHPRF ON		6.0	12.0	mA
				(*B)Through mode		2.5	4.0	mA
Input voltage	CLK	H level	VIH1		0.7VDD			V
		L level	VIL1				0.3VDD	V
			VINAC	AC coupling	0.3			Vp-p
	(*2,3,4)	H level	VIH2		0.7VDD			V
		L level	VIL2				0.3VDD	V
	(*5)	H level	VIH3		0.6VDD			V
L level		VIL3				0.2VDD	V	
Output voltage	(*4,6)	H level	VOH1	IOH = - 0.5 mA	VDD - 0.4			V
		L level	VOL1	IOL = 0.5 mA			0.4	V
	(*5,7)	H level	VOH2	IOH = - 0.5 mA	VDD - 0.4			V
		L level	VOL2	IOL = 0.5 mA			0.4	V
Input current	CLK	IIH1		VIN = VDD	10	30	115	μA
		IIL1		VIN = 0V	10	30	115	μA
	(*3,4)	IIL2		VIN = 0V	1.5	3	15	μA
Input leakage current	(*2,3,4,5)	ILH		VIN = VDD			1.0	μA
	(*2,5)	ILL		VIN = 0V			1.0	μA

(*B) VDD1 = VDD2 = 3 V, CLK input frequency fXTI= 384fs = 16.9344 MHz, all outputs unloaded,
SHPRF: Shock-proof,
typical values are for VDD1 = VDD2 = 3 V.

<Pin summary>

(*1)	Pin function	Clock input pin (AC input)
	Pin name	CLK
(*2)	Pin function	Schmitt input pins
	Pin name	YSRDATA, YLRCK, YSCK, YFLAG, YFCLK, NRESET, YBLKCK, YDMUTE, YMLD, YMDATA, YMCLK
(*3)	Pin function	Schmitt input pin with pull-up
	Pin name	NTEST
(*4)	Pin function	I/O pins (Schmitt input with pull-up in input state)
	Pin name	UC1, UC2, UC3, UC4, UC5
(*5)	Pin function	I/O pins (Schmitt input in input state)
	Pin name	D0, D1, D2, D3
(*6)	Pin function	Outputs
	Pin name	ZSCK, ZLRCK, ZSRDATA, ZSENSE, DIT
(*7)	Pin function	Outputs
	Pin name	NCAS, NWE, NRAS, A0, A1, A2, A3, A4, A5, A6, A7, A8, A9,A10

AC characteristics

Standard voltage: $V_{DD1} = V_{DD2} = 4.5$ to 5.5 V, $V_{SS} = 0$ V, $T_a = -40$ to 85 °C

Low-voltage: $V_{DD1} = V_{DD2} = 2.4$ to 4.5 V, $V_{SS} = 0$ V, $T_a = -20$ to 70 °C

(*) Typical values are for $f_s = 44.1$ kHz

System clock (CLK pin)

Parameter	Symbol	Condition System clock	Rating			Unit
			Min	Typ	Max	
Clock pulsewidth (HIGH level)	t_{CWH}		26	29.5	125	ns
Clock pulsewidth (LOW level)	t_{CWL}		26	29.5	125	ns
Clock pulse cycle	t_{CY}	384fs	56	59	250	ns

System clock input

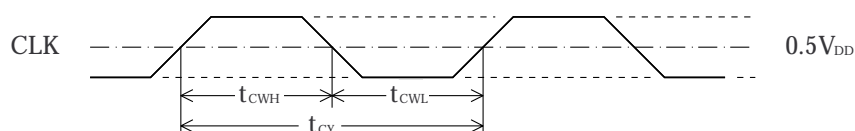

Serial input (YSRDATA, YLRCK, YSCK pins)

Parameter	Symbol	Rating			Unit	Condition
		Min	Typ	Max		
YSCK pulsewidth (HIGH level)	t_{BCWH}	75			ns	
YSCK pulsewidth (LOW level)	t_{BCWL}	75			ns	
YSCK pulse cycle	t_{BCY}	150			ns	
YSRDATA setup time	t_{DS}	50			ns	
YSRDATA hold time	t_{DH}	50			ns	
Last YSCK rising edge to YLRCK edge	t_{BL}	50			ns	
YLRCK edge to first YSCK rising edge	t_{LB}	50			ns	
YLRCK pulse frequency See note below.		0		3fs		Memory system ON (MSON=H)
		fs		fs		Memory system OFF (MSON=L)

Note. When the memory system is OFF (through mode), the input data rate is synchronized to the system clock input (384fs), so input data needs to be at 1/384 of this frequency. But, this IC can tolerate a certain amount of jitter. For details, refer to Through-mode operation.

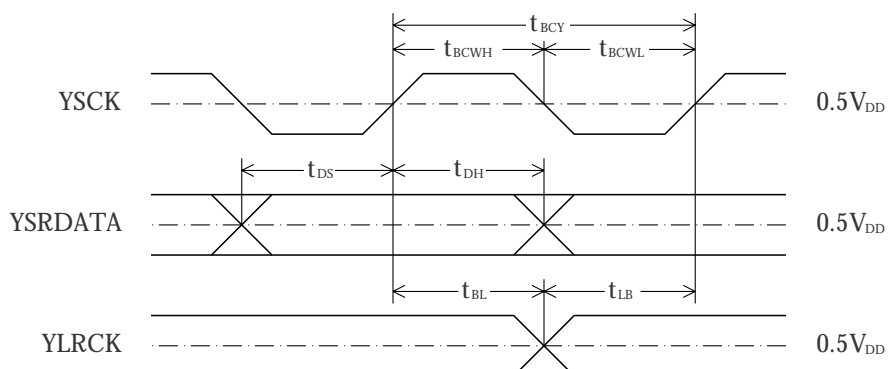

Microcontroller interface (YMCLK, YMDATA, YMLD, ZSENSE pins)

Parameter	Symbol	Rating			Unit
		Min	Typ	Max	
YMCLK LOW-level pulsewidth	t_{MCWL}	$30 + 2t_{CY}$			ns
YMCLK HIGH-level pulsewidth	t_{MCWH}	$30 + 2t_{CY}$			ns
YMDATA setup time	t_{MDS}	$30 + t_{CY}$			ns
YMDATA hold time	t_{MDH}	$30 + t_{CY}$			ns
YMLD LOW-level pulsewidth	t_{MLWL}	$30 + 2t_{CY}$			ns
YMLD setup time	t_{MLS}	$30 + t_{CY}$			ns
YMLD hold time	t_{MLH}	$30 + t_{CY}$			ns
Rise time	t_r			100	ns
Fall time	t_f			100	ns
ZSENSE output delay	t_{PZS}			$100 + 3t_{CY}$	ns

Note. t_{CY} is the system clock cycle time (59ns typ).

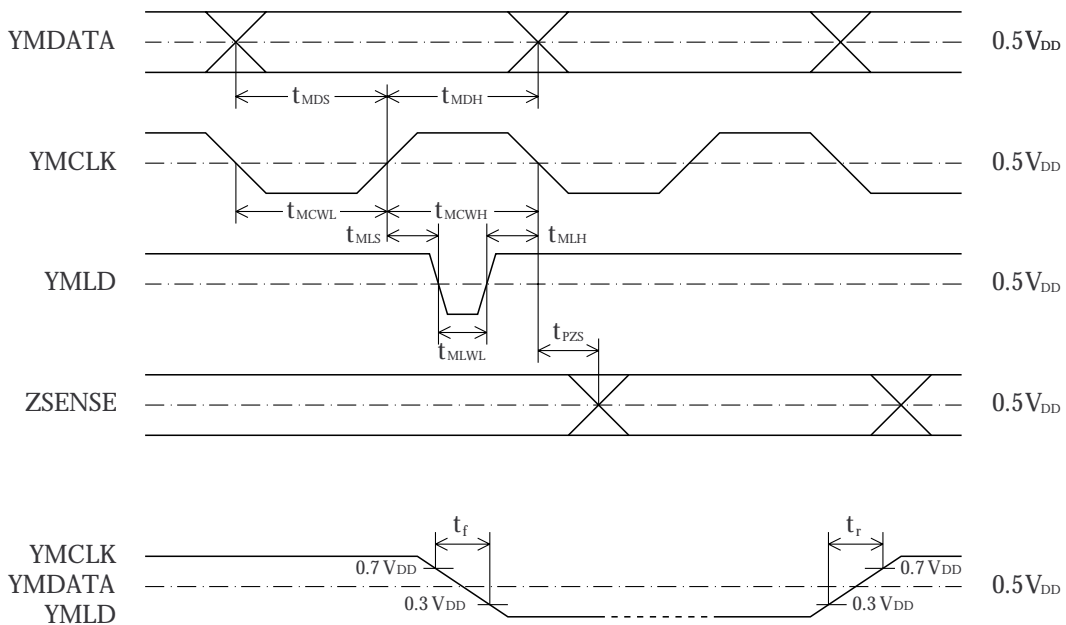

Reset input (NRESET pin)

Parameter	Symbol	Rating			Unit
		Min	Typ	Max	
First HIGH-level after supply voltage rising edge	t_{HNRST}	0			t_{CY} (Note)
NRESET pulsewidth	t_{NRST}	64			t_{CY} (Note)

Note. t_{CY} is the system clock (CLK) input (384fs) cycle time.

$t_{CY} = 59 \text{ ns}$, $t_{NRST} (\text{min}) = 3.8 \mu\text{s}$ when $f_s = 44.1 \text{ kHz}$

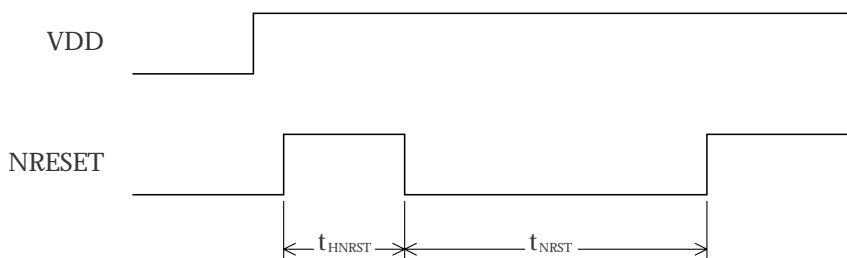

SM5902AF

Serial output (ZSRDATA, ZLRCK, ZSCK pins)

Parameter	Symbol	Condition	Rating			Unit
			Min	Typ	Max	
ZSCK pulsewidth	t_{SCOW}	15 pF load		1/96fs		
ZSCK pulse cycle	t_{SCOY}	15 pF load		1/48fs		
ZSRDATA and ZLRCK output delay time	t_{DHL}	15 pF load	0		60	ns
	t_{DLH}	15 pF load	0		60	ns

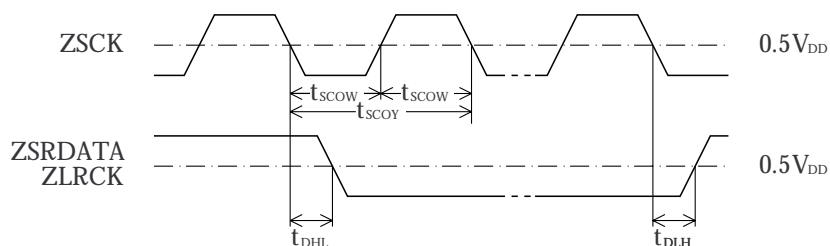

DRAM access timing (NRAS, NCAS, NCAS2, NWE, A0 to A10, D0 to D3)

Parameter		Symbol	Condition	Rating			Unit
				Min	Typ	Max	
NRAS pulsewidth		t_{RASL}	15 pF load		5		$t_{CY}(\text{note})$
		t_{RASH}	15 pF load	3			t_{CY}
NRAS falling edge to NCAS falling edge		t_{RCD}	15 pF load		2		t_{CY}
NCAS pulsewidth		t_{CASH}	15 pF load	5			t_{CY}
		t_{CASL}	15 pF load		3		t_{CY}
NRAS falling edge to address	Setup time	t_{RADS}	15 pF load		1		t_{CY}
	Hold time	t_{RADH}	15 pF load		1		t_{CY}
NCAS falling edge to address	Setup time	t_{CADS}	15 pF load		1		t_{CY}
	Hold time	t_{CADH}	15 pF load		5		t_{CY}
NCAS falling edge to data write	Setup time	t_{CWDS}	15 pF load		3		t_{CY}
	Hold time	t_{CWDH}	15 pF load		3		t_{CY}
NCAS rising edge to data read	Input setup	t_{CRDS}		40			ns
	Input hold	t_{CRDH}		0			ns
NWE pulsewidth		t_{WEL}	15 pF load		6		t_{CY}
NWE falling edge to NCAS falling edge		t_{WCS}	15 pF load		3		t_{CY}
Refresh cycle ($f_s = 44.1$ kHz playback) Memory system ON Decode sequence operation (RDEN=H)		t_{REF}	1M DRAM $\times 1$	Non compression		1.5	ms
				6-bit compression		3.7	ms
				5-bit compression		4.4	ms
				4-bit compression		5.5	ms
			4M DRAM $\times 1$ or $\times 2$	Non compression		3.0	ms
				6-bit compression		7.3	ms
				5-bit compression		8.8	ms
				4-bit compression		10.9	ms
			16M DRAM $\times 1$	Non compression		5.9	ms
				6-bit compression		14.6	ms
				5-bit compression		17.5	ms
				4-bit compression		21.8	ms

Note. t_{CY} is the system clock (CLK) input (384fs) cycle time. $t_{CY} = 59$ ns when $f_s = 44.1$ kHz

DRAM access timing (with single DRAM)

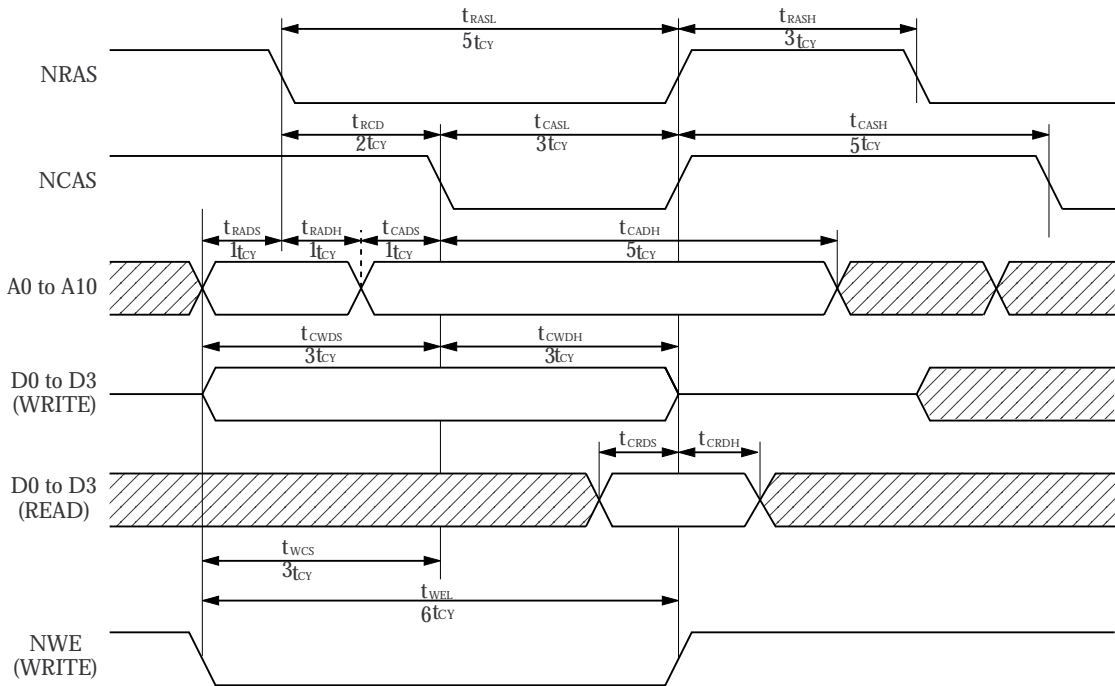

The NWE terminal output is fixed HIGH during read timing.

DRAM access timing (with 2 DRAMs)

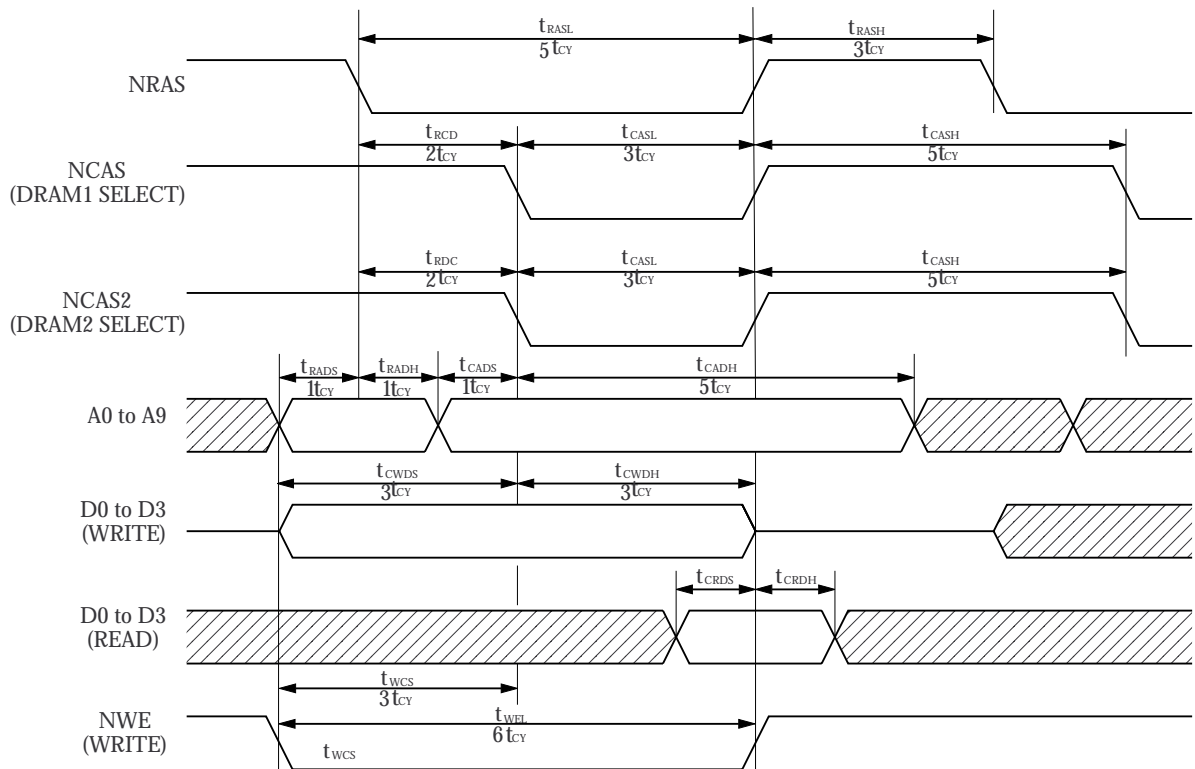

The NWE terminal output is fixed HIGH during read timing.

NCAS terminal output is fixed HIGH when selecting "DRAM2".

NCAS2 terminal output is fixed HIGH when selecting "DRAM1".

SM5902AF

DIT Interface (DIT pin)

Parameter	Symbol	Condition	Rating			Unit
			Min	Typ	Max	
0 data H level	t_{D10H}	15 pF load		6		$t_{CY}(\text{Note})$
0 data L level	t_{D10L}	15 pF load		6		t_{CY}
1 data H level	t_{D11H}	15 pF load		3		t_{CY}
1 data L level	t_{D11L}	15 pF load		3		t_{CY}

Note. t_{CY} is the system clock (CLK) input (384fs) cycle time. $t_{CY} = 59 \text{ ns}$ when $f_s = 44.1 \text{ kHz}$.

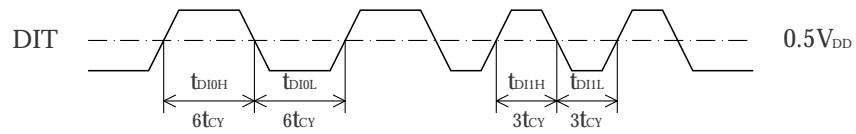

Block diagram

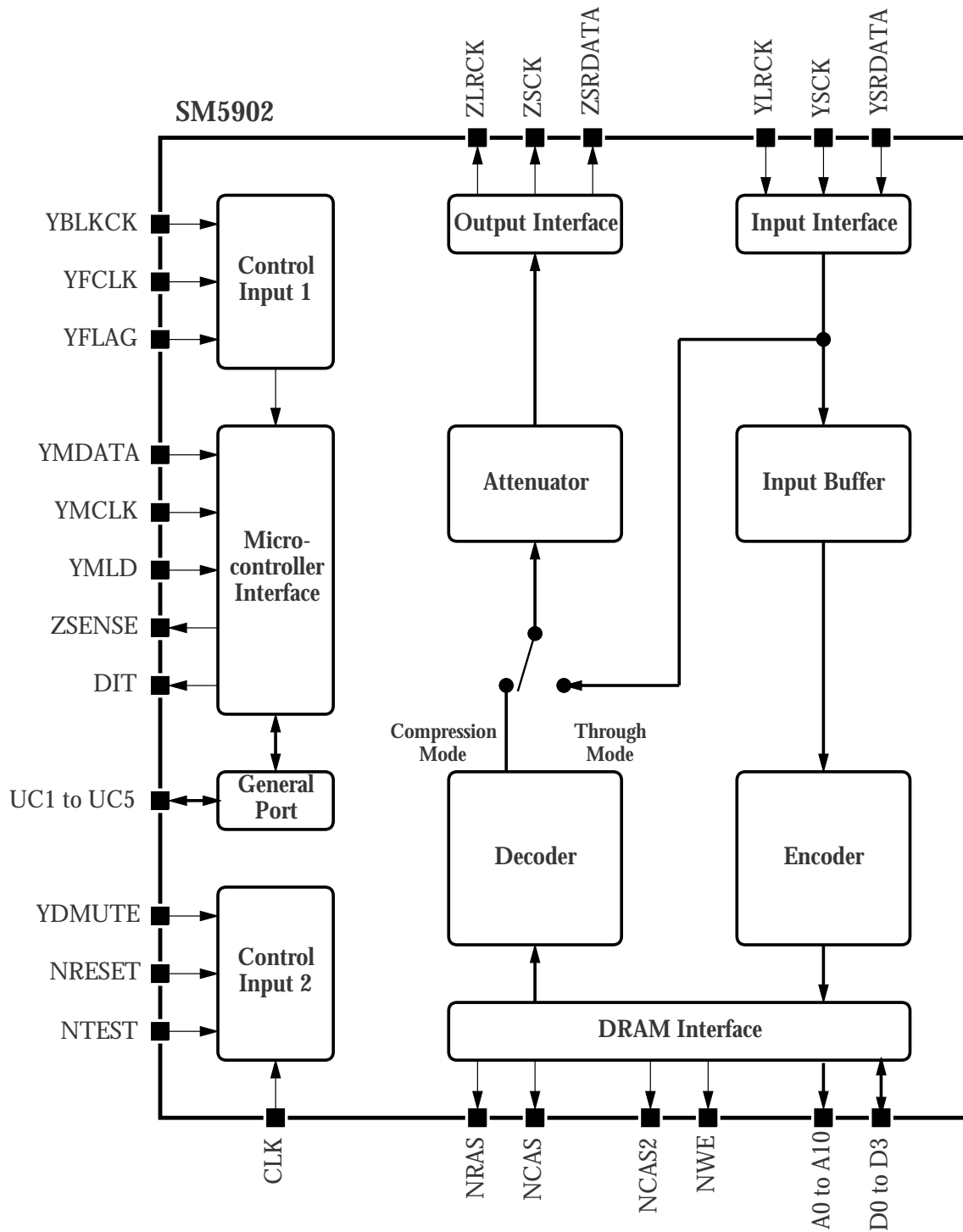

Functional description

SM5902AF has two modes of operation; shock-proof mode and through mode.

The operating sequences are controlled using commands from a microcontroller.

Microcontroller interface

Commands from the microcontroller are input using 3-wire serial interface inputs; data (YMDATA), bit clock (YMCLK) and load signal (YMLD).

In the case of a read command from the microcontroller, bit serial data is output (ZSENSE) synchronized to the bit clock input (YMCLK).

Write command format (Commands 80 to 86)

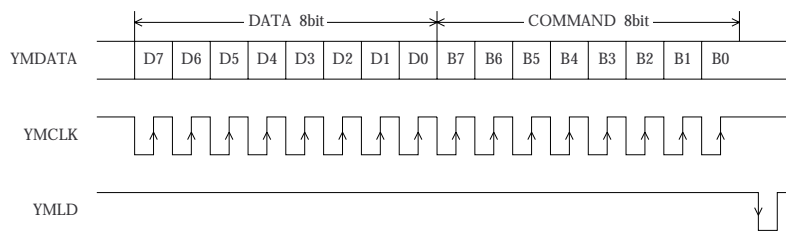

Write command format (Commands 87)

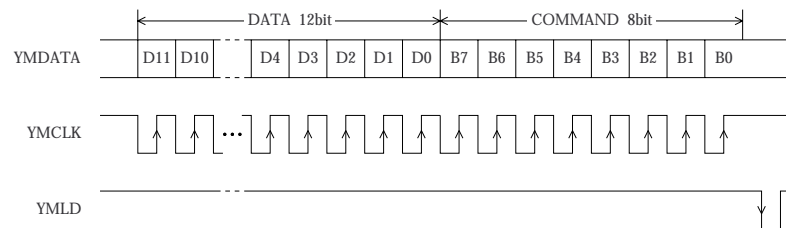

Read command format (Commands 90, 91, 93)

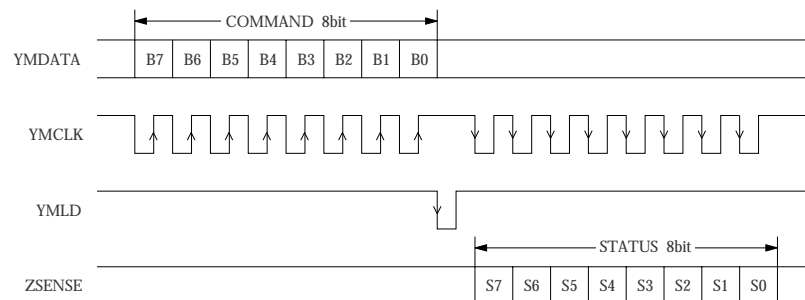

Read command format (Command 92 (memory residual read))

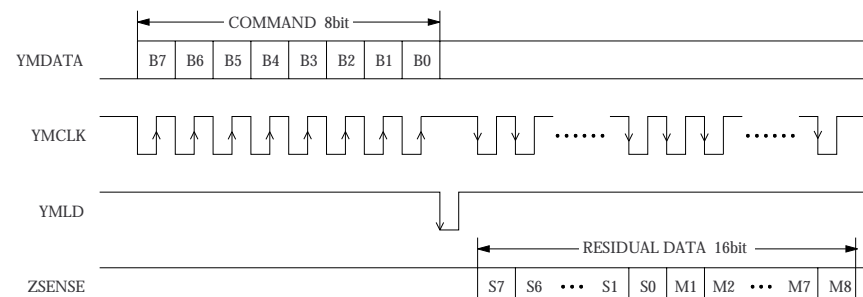

Command table**Write command summary****MS command 80****Shock-proof memory system settings****80hex = 1000 0000**
B7 B6 B5 B4 B3 B2 B1 B0

Bit	Name	Function	H operation	Reset level
D7	MSWREN	Encode sequence start/stop	Start	L
D6	MSWACL	Write address reset	Reset	L
D5	MSRDEN	Decode sequence start/stop	Start	L
D4	MSRACL	Read address reset	Reset	L
D3	MSDCN2	MSDCN2=H, MSDCN1=H: 3-pair comparison start		L
		MSDCN2=H, MSDCN1=L: 2-pair comparison start		
D2	MSDCN1	MSDCN2=L, MSDCN1=H: Direct-connect start		L
		MSDCN2=L, MSDCN1=L: Connect operation stop		
D1	WAQV	Q data valid	Valid	L
D0	MSON	Memory system ON	ON	L

Extension I/O settings 81**Extension I/O port input/output settings****81hex = 1000 0001**
B7 B6 B5 B4 B3 B2 B1 B0

Bit	Name	Function	H operation	Reset level
D7				
D6				
D5				
D4	UC5OE	Extension I/O port UC5 input/output setting	Output	L
D3	UC4OE	Extension I/O port UC4 input/output setting	Output	L
D2	UC3OE	Extension I/O port UC3 input/output setting	Output	L
D1	UC2OE	Extension I/O port UC2 input/output setting	Output	L
D0	UC1OE	Extension I/O port UC1 input/output setting	Output	L

Extension I/O output data settings 82**Extension port HIGH/LOW output level**

A port setting is invalid if that port has already been defined as an input using the 81H command above.

82hex = 1000 0010
B7 B6 B5 B4 B3 B2 B1 B0

Bit	Name	Function	H operation	Reset level
D7				
D6				
D5				
D4	UC5WD	Extension I/O port UC5 output data setting	H output	L
D3	UC4WD	Extension I/O port UC4 output data setting	H output	L
D2	UC3WD	Extension I/O port UC3 output data setting	H output	L
D1	UC2WD	Extension I/O port UC2 output data setting	H output	L
D0	UC1WD	Extension I/O port UC1 output data setting	H output	L

SM5902AF

ATT, MUTE settings 83

83hex = 1000 0011
B7 B6 B5 B4 B3 B2 B1 B0

Bit	Name	Function	H operation	Reset level
D7	ATT	Attenuator enable	Attenuator ON	L
D6	MUTE	Forced muting (changes instantaneously)	Mute ON	L
D5	SOFT	Soft muting (changes smoothly when ON only)	Soft mute	L
D4	NS	Includes noise shaper function when encoding	NS ON	L
D3	CMP12	12-bit comparison connect/ 16-bit comparison connect	12-bit comparison	L
D2				
D1				
D0				

Refer to "Attenuation", "Soft mute", "Force mute", "12-bit comparison connection".

Attenuation level settings 84

84hex = 1000 0100
B7 B6 B5 B4 B3 B2 B1 B0

Bit	Name	Function	H operation	Reset level
D7	K7	MSB 2^{-1}		L
D6	K6	2^{-2}		H
D5	K5	2^{-3}		L
D4	K4	2^{-4}		L
D3	K3	2^{-5}		L
D2	K2	2^{-6}		L
D1	K1	2^{-7}		L
D0	K0	LSB 2^{-8}		L

Refer to "Attenuation", "Soft mute", "Force mute".

Option settings 85

85hex = 1000 0101
B7 B6 B5 B4 B3 B2 B1 B0

Bit	Name	Function	H operation	Reset level
D7	RAMS1	DRAM type setting		L
D6	RAMS2	RAMS1=0 RAMS2=0 when 1MDRAM(256k × 4bit) × single RAMS1=1 RAMS2=0 when 4MDRAM(1M × 4bit) × single RAMS1=0 RAMS2=1 when 4MDRAM(1M × 4bit) × double RAMS1=1 RAMS2=1 when 16MDRAM(4M × 4bit) × single		L
D5	YFLGS	FLAG6 set conditions (reset using status read command 90H) - When YFLGS=0, YFCKP=0, YFCLK input falling edge, YFLAG=L - When YFLGS=0, YFCKP=1, YFCLK input rising edge, YFLAG=L		L
D4	YFCKP	- When YFLGS=1, YFCKP=0, YFLAG=L - When YFLGS=1, YFCKP=1, YFLAG=H		L
D3	COMPFB	Full-bit compression mode		L
D2	COMP6B	6-bit compression mode		H
D1	COMP5B	5-bit compression mode		L
D0	COMP4B	4-bit compression mode		L

When the number of compression bits is set incorrectly (2 or more bits in D0 to D3 are set to 1 or all bits are set to 0),
6-bit compression mode is selected.

SM5902AF

Digital Audio Interface settings 86

86hex = ^{B7}1000 ^{B6}^{B5}0110 ^{B4}^{B3}^{B2}^{B1}^{B0}

Bit	Name	Function	H operation	Reset level	
D7	CP1	Channel status and clock accuracy setting CP1= 0, CP2= 0 Level 2 (max ± 300 ppm) CP1= 0, CP2= 1 Level 3 (max ± 10 %) CP1= 1, CP2= 0 Level 1 (max ± 50 ppm) CP1= 1, CP2= 1 Not supported		L	
D6	CP2			L	
D5	LBIT		Digital audio signal generation logic. 0 = post-recording software	Unassigned	L
D4	DIT		Digital audio interface (DIT) enable. 0 = DIT output LOW	DIT= ON	L
D3					
D2					
D1					
D0					

Sub code Q data settings 87

87hex = ^{B7}1000 ^{B6}^{B5}0111 ^{B4}^{B3}^{B2}^{B1}^{B0}

Bit	Name	Function	H operation	Reset level
D11	QAD3	Q data setting and word address specification QAD3 (MSB) to QAD0 (LSB) specify one of 10 valid addresses in the range 0000 to 1001. * If an address in the range 1010 to 1111 is specified, the data on QD7 to QD0 is ignored. Note that writing to address 1001 also functions as the write stop command.		L
D10	QAD2			L
D9	QAD1			L
D8	QAD0			L
D7	QD7	MSB Q data setting ward data		Undefined
D6	QD6	Q data setting ward data		Undefined
D5	QD5	Q data setting ward data		Undefined
D4	QD4	Q data setting ward data		Undefined
D3	QD3	Q data setting ward data		Undefined
D2	QD2	Q data setting ward data		Undefined
D1	QD1	Q data setting ward data		Undefined
D0	QD0	LSB Q data setting ward data		Undefined

Address map for Q data setting beuffer

QAD3	QAD2	QAD1	QAD0	QD7	QD6	QD5	QD4	QD3	QD2	QD1	QD0
0	0	0	0	CTL0	CTL1	CTL2	CTL3	ADR3	ADR2	ADR1	ADR0
0	0	0	1	DQ1	DQ2	DQ3	DQ4	DQ5	DQ6	DQ7	DQ8
0	0	1	0	DQ9	DQ10	DQ11	DQ12	DQ13	DQ14	DQ15	DQ16
0	0	1	1	DQ17	DQ18	DQ19	DQ20	DQ21	DQ22	DQ23	DQ24
0	1	0	0	DQ25	DQ26	DQ27	DQ28	DQ29	DQ30	DQ31	DQ32
0	1	0	1	DQ33	DQ34	DQ35	DQ36	DQ37	DQ38	DQ39	DQ40
0	1	1	0	DQ41	DQ42	DQ43	DQ44	DQ45	DQ46	DQ47	DQ48
0	1	1	1	DQ49	DQ50	DQ51	DQ52	DQ53	DQ54	DQ55	DQ56
1	0	0	0	DQ57	DQ58	DQ59	DQ60	DQ61	DQ62	DQ63	DQ64
1	0	0	1	DQ65	DQ66	DQ67	DQ68	DQ69	DQ70	DQ71	DQ72

When shockproof mode is ON, the Q data is specified according to the data output from the SM5902AF.

Read command summary

Shock-proof memory status (1) 90

$$90\text{hex} = \overset{\text{E7}}{1}\overset{\text{E6}}{0}\overset{\text{E5}}{0}\overset{\text{E4}}{0}\overset{\text{E3}}{0}\overset{\text{E2}}{0}\overset{\text{E1}}{0}\overset{\text{E0}}{0}$$

Bit	Name	Function	HIGH-level state
S7	FLAG6	Signal processor IC jitter margin exceeded	Exceeded
S6	MSOVF	Write overflow (Read once only when RA exceeds WA)	DRAM overflow
S5	BOVF	Input buffer memory overflow because sampling rate of input data is too fast	Input buffer memory overflow
S4			
S3	DCOMP	Data compare-connect sequence operating	Compare-connect sequence operating
S2	MSWIH	Encode sequence stop due to internal factors	Encoding stopped
S1	MSRIH	Decode sequence stop due to internal factors	Decoding stopped
S0			

Refer to "Status flag operation summary".

Shock-proof memory status (2) 91

$$91\text{hex} = \overset{\text{E7}}{1}\overset{\text{E6}}{0}\overset{\text{E5}}{0}\overset{\text{E4}}{0}\overset{\text{E3}}{0}\overset{\text{E2}}{0}\overset{\text{E1}}{0}\overset{\text{E0}}{1}$$

Bit	Name	Function	HIGH-level state
S7	MSEMP	Valid data empty state (Always HIGH when RA exceeds VWA)	No valid data
S6	OVFL	Write overflow state (Always HIGH when WA exceeds RA)	Memory full
S5	ENCOD	Encode sequence operating state	Encoding
S4	DECOD	Decode sequence operating state	Decoding
S3	QRDY	Subcode Q data write-buffer write enable	Write enabled
S2			
S1			
S0			

Refer to "Status flag operation summary".

Shock-proof memory valid data residual 92

92hex = ^{B7}1001 ^{B6}^{B5}0010 ^{B4}

Bit	Name	Function	
S7	AM21	Valid data accumulated VWA-RA (MSB) 8M bits	
S6	AM20	4M bits	
S5	AM19	2M bits	
S4	AM18	1M bits	
S3	AM17	512k bits	
S2	AM16	256k bits	
S1	AM15	128k bits	
S0	AM14	64k bits	
M1	AM13	32k bits	
M2	AM12	16k bits	
M3	AM11	8k bits	
M4	AM10	4k bits	
M5	AM09	2k bits	
M6	AM08	1k bits	
M7	AM07	512 bits	
M8	AM06	256 bits	

Note. The time conversion factor varies depending on the compression bit mode. (M = 1,048,576 K = 1,024)

$$\text{Residual time (sec)} = \text{Valid data residual (Mbits)} \times \text{Time conversion value K}$$

where the Time conversion value K (sec/Mbit) \approx 2.78 (4 bits), 2.22 (5 bits), 1.85 (6 bits) and 0.74 (Full bits).

Extension I/O inputs 93

Input data entering (or output data from) an extension port terminal is echoed to the microcontroller.
 (That is, the input data entering an I/O port configured as an input port using the 81H command,
 OR the output data from a pin configured as an output port using the 82H command.)

93hex = ^{B7}1001 ^{B6}^{B5}0011 ^{B4}

Bit	Name	Function	HIGH-level state
S7			
S6			
S5			
S4	UC5RD		
S3	UC4RD		
S2	UC3RD		
S1	UC2RD		
S0	UC1RD		

SM5902AF

Status flag operation summary

Flag name	Read method		
FLAG6	READ 90H bit 7	Meaning	- Indicates to the CD signal processor DSP (used for error correction, de-interleaving) that a disturbance has exceeded the RAM jitter margin.
		Set	- Set according to the YFLAG input and the operating state of YFCKP and YFLGS. FLAG6 set conditions When YFLGS=0, YFCKP=0, YFCLK input falling edge, YFLAG=L When YFLGS=0, YFCKP=1, YFCLK input rising edge, YFLAG=L When YFLGS=1, YFCKP=0, YFLAG=L When YFLGS=1, YFCKP=1, YFLAG=H
		Reset	- By 90H status read - By 80H command when MSON=ON - After external reset
MSOVF	READ 90H bit 6	Meaning	- Indicates once only that a write to external DRAM has caused an overflow. (When reset by the 90H status read command, this flag is reset even if the overflow condition continues.)
		Set	- When the write address (WA) exceeds the read address (RA)
		Reset	- By 90H status read - When a read address clear (MSRACL) or write address clear (MSWACL) command is issued - After external reset
BOVF	READ 90H bit 5	Meaning	- Indicates input data rate was too fast causing buffer overflow and loss of data
		Set	- When inputs a data during a buffer memory overflow
		Reset	- By 90H status read - When a read address clear (MSRACL) or write address clear (MSWACL) command is issued - After external reset
DCOMP	READ 90H bit 3	Meaning	- Indicates that a compare-connect sequence is operating
		Set	- When a (3-pair or 2-pair) compare-connect start command is received (MSDCN2=1) - When a direct connect command is received (MSDCN2=0, MSDCN1=1)
		Reset	- When a (3-pair or 2-pair) comparison detects conforming data - When the connect has been performed after receiving a direct connect command - When a compare-connect stop command (MSDCN2=0, MSDCN1=0) is received - When a MSWREN=1 command is received (However, if a compare-connect command is received at the same time, the compare-connect command has priority.) - After external reset
MSWIH	READ 90H bit 2	Meaning	- Indicates that the encode sequence has stopped due to internal factors (not microcontroller commands)
		Set	- When FLAG6 (above) is set - When BOVF (above) is set - When MSOVF (above) is set
		Reset	- When conforming data is detected after receiving a compare-connect start command - When the connect has been performed after receiving a direct connect command - When a read address clear (MSRACL) or write address clear (MSWACL) command is received - After external reset
MSRIH	READ 90H bit 1	Meaning	- Indicates that the decode sequence has stopped due to internal factors (not microcontroller commands)
		Set	- When the valid data residual becomes 0
		Reset	- By 90H status read - When a read address clear (MSRACL) or write address clear (MSWACL) command is issued - After external reset

SM5902AF

Flag name	Read method		
MSEMP	READ 91H bit 7	Meaning	- Indicates that the valid data residual has become 0
		Set	- When the VWA (final valid data's next address) = RA (address from which the next read would take place)
		Reset	- Whenever the above does not apply
OVFL	READ 91H bit 6	Meaning	- Indicates a write to external DRAM overflow state
		Set	- When the write address (WA) exceeds the read address (RA). (Note: This flag is not set when WA=RA through an address initialize or reset operation.)
		Reset	- When the read address (RA) is advanced by the decode sequence - When a read address clear (MSRACL) or write address clear (MSWACL) command is issued - After external reset
ENCOD	READ 91H bit 5	Meaning	- Indicates that the encode sequence (input data entry, encoding, DRAM write) is operating
		Set	- By the 80H command when MSWREN=1 - When conforming data is detected during compare-connect operation - When the connect has been performed after receiving a direct connect command
		Reset	- When the FLAG6 flag=1 (above) - When the OVFL flag=1 (above) - By the 80H command when MSWREN=0 - By the 80H command when MSDCN1=1 or MSDCN2=1 (compare-connect start command) - By the 80H command when MSON=0 - After external reset Note. Reset conditions have priority over set conditions. For example, if the 80H command has MSWREN=1 and MSDCN1=1, the ENCOD flag is reset and compare-connect operation starts.
DECOD	READ 91H bit 4	Meaning	- Indicates that the decode sequence (read from DRAM, decoding, attenuation, data output) is operating
		Set	- By a new 80H command when MSRDEN=1 and the MSEMP flag=0 (above)
		Reset	- Whenever the above does not apply
QRDY	READ 91H bit 3	Meaning	Subcode Q data write-buffer write enable indicator
		Set	After internal subcode Q data write-buffer contents are read out.
		Reset	When data is written to address 1001 using the 87H command.

Write command supplementary information**80H (MS command)****- MSWREN**

When 1: Encode sequence starts

Invalid when MSON is not 1 within the same 80H command

Invalid when FLAG6=1

Invalid when OVFL=1

Invalid when a compare-connect start command (MSDCN2=1 or MSDCN1=1) occurs simultaneously

Direct connect if a compare-connect sequence is already operating

When 0: Encode sequence stops

- MSWACL

When 1: Initializes the write address (WA)

When 0: No operation

- MSRDEN

When 1: Decode sequence starts

Does not perform decode sequence if MSON=1. If there is no valid data, decode sequence temporarily stops. But, because the MSRDEN flag setting is maintained as is, the sequence automatically re-starts when valid data appears.

When 0: Decode sequence stops

-MSRACL

When 1: Initializes the read address (RA)

When 0: No operation

- MSDCN2, MSDCN1

When 1 and 1: 3-pair compare-connect sequence starts

When 1 and 0: 2-pair compare-connect sequence starts

When 0 and 1: Direct connect sequence starts

When 0 and 0: Compare-connect sequence stops. No operation if a compare-connect sequence is not operating.

- WAQV

When 1: The immediately preceding YBLKCK falling-edge timing WA (write address) becomes the VWA (valid write address).

When 0: No operation

- MSON

When 1: Memory system turns ON and shock-proof operation starts

When 0: Memory system turns OFF and through-mode playback starts. (In this mode, the attenuator is still active.)

81H (Extension I/O port settings)**82H (Extension I/O port output data settings)**

83H (ATT, MUTE, 12-bit comparison connection settings)**- ATT (attenuator enable)**

When 1: Attenuator settings become active (84H command)

When 0: Attenuator settings become inactive, and output continues without attenuation

- MUTE (forced muting)

When 1: Outputs are instantaneously muted to 0.(note 1)

Same effect as taking the YDMUTE pin HIGH.

When 0: No muting(note 1)

(note1) Effective at the start of left-channel output data.

- SOFT (soft muting)

When 1: Outputs are smoothly muted to 0.

When 0: No muting.

Soft mute release occurs instantaneously to either the value set by the 84H command (When ATT=1) or 0dB (When ATT=0)

- MUTE, SOFT, YDMUTE relationship

When all mute inputs are 0, mute is released.

- NS (noise shaper enable)

When 1: Includes noise shaper function in compression-mode shockproof operation.

When 0: Performs comparison connection using all 16 bits of input data.

- CMP12 (12-bit comparison connection)

When 1: Performs comparison connection using only the most significant 12 bits of input data.

When 0: Performs comparison connection using all 16 bits of input data.

85H (option settings)**- RAMS1, RAMS2**

When 0 and 0 : 1M DRAMs (256k×4 bits)×single

When 1 and 0 : 4M DRAMs (1M×4 bits)×single

When 0 and 1 : 4M DRAMs (1M×4 bits)×double

When 1 and 1 : 16M DRAMs (4M×4 bits)×single

- RAMX2

When 1: Uses 2 DRAMs

When 0: Uses a single DRAM

- YFLGS, YFCKP

When 0 and 0: Sets FLAG6 on the falling edge of YFCLK when YFLAG=0

When 0 and 1: Sets FLAG6 on the rising edge of YFCLK when YFLAG=0

When 1 and 0: Sets FLAG6 when YFLAG=0

When 1 and 1: Sets FLAG6 when YFLAG=1

- COMPFB, COMP6B, COMP5B, COMP4B

When 0, 0, 0 and 1: Selects 4-bit compression mode

When 0, 0, 1 and 0: Selects 5-bit compression mode

When 1, 0, 0 and 0: Selects full-bit compression mode

In all other cases: Selects 6-bit compression mode
Changing mode without initializing during operation is possible.

86H (digital audio interface settings)

- CP1, CP2 (channel status and clock accuracy setting)

When 0 and 0: Level 2 (max ± 300 ppm)

When 0 and 1: Level 3I (max ± 10%)

When 1 and 0: Level 1 (max ± 50 ppm)

When 1 and 1: Not supported

- LBIT (digital audio signal generation logic)

When 1: Not assigned

When 0: Post-recording software

- DIT (digital audio interface enable)

When 1: DIT output enable

When 0: DIT LOW-level output

87H (subcode Q data setting)

- QAD3 to QAD0 (Q data setting and word address specification)

QAD3 (MSB) to QAD0 (LSB) specify one of 10 valid addresses in the range 0000 to 1001.

If an address in the range 1010 to 1111 is specified, the data on QD7 to QD0 is ignored.

Note that writing to address 1001 also functions as the write stop command.

- QD7 to QD0 (Q data setting and word data)

The CD Q-channel has the general data format shown below.

The write data required to fully specify the Q data is the 80 bits comprising CONTROL, ADR, and DATA-Q.

The CRC write data is not required because it is generated by recalculation.

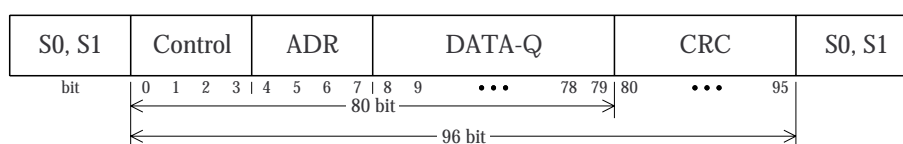

Address map for Q data setting beuffer

QAD3	QAD2	QAD1	QAD0	QD7	QD6	QD5	QD4	QD3	QD2	QD1	QD0
0	0	0	0	CTL0	CTL1	CTL2	CTL3	ADR3	ADR2	ADR1	ADR0
0	0	0	1	DQ1	DQ2	DQ3	DQ4	DQ5	DQ6	DQ7	DQ8
0	0	1	0	DQ9	DQ10	DQ11	DQ12	DQ13	DQ14	DQ15	DQ16
0	0	1	1	DQ17	DQ18	DQ19	DQ20	DQ21	DQ22	DQ23	DQ24
0	1	0	0	DQ25	DQ26	DQ27	DQ28	DQ29	DQ30	DQ31	DQ32
0	1	0	1	DQ33	DQ34	DQ35	DQ36	DQ37	DQ38	DQ39	DQ40
0	1	1	0	DQ41	DQ42	DQ43	DQ44	DQ45	DQ46	DQ47	DQ48
0	1	1	1	DQ49	DQ50	DQ51	DQ52	DQ53	DQ54	DQ55	DQ56
1	0	0	0	DQ57	DQ58	DQ59	DQ60	DQ61	DQ62	DQ63	DQ64
1	0	0	1	DQ65	DQ66	DQ67	DQ68	DQ69	DQ70	DQ71	DQ72

- Subcode Q data setting process

Initially, data is written to word address range 0000 to 1000, and then data is written to address 1001. Next, only data that needs to be changed is written if the 91H command QRDY bit is 1, and

then address 1001 is written again. Note that when shockproof mode is ON, the Q data is specified according to the data output from the SM5902AF.

Shock-proof operation overview

Shock-proof mode is the mode that realizes shock-proof operation using external DRAM. Shock-proof mode is invoked by setting MSON=H in microcon-

troller command 80H.

This mode comprises the following 3 sequences.

- Encode sequence

1. Input data from a signal processor IC is stored in internal buffers.
2. Encoder starts after a fixed number of data have been received.

3. The encoder, after the most suitable predicting filter type and quantization steps have been determined, performs ADPCM encoding and then writes to external DRAM.

- Decode sequence

1. Reads compressed data stored in external buffer RAM at rate f_s .
2. Decoder starts, using the predicting filter type and quantization levels used when encoded.

3. Performs attenuation operation (including muting operation)
4. Outputs the result.

- Compare-connect sequence

1. Encoding immediately stops when either external buffer RAM overflows or when a CD read error occurs due to shock vibrations.
2. Then, using microcontroller command 80H, the compare-connect start command is executed and compare-connect sequence starts.

3. Compares data re-read from the CD with the processed final valid data stored in RAM (confirms its correctness).
4. As soon as the comparison detects conforming data, compare-connect sequence stops and encode sequence re-starts, connecting the data directly behind previous valid data.

RAM addresses

The SM5902 uses either 1 or 2 external 1M or 4M DRAMs as external buffers.

Three kinds of addresses are used for external RAM control.

WA (write address)

RA (read address)

VWA (valid write address)

Among these, VWA is the write address for conforming data whose validity has been confirmed. Determination of the correctness of data read from the CD is delayed relative to the encode write processing, so VWA is always delayed relative to WA.

The region available for valid data is the area between VWA-RA.

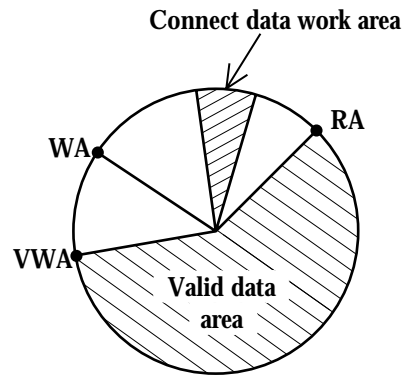

Fig 1. RAM addresses

- Connect data work area

This is an area of memory reserved for connect data. This area is 2k bits if using 1M DRAMs, 4k bits if using 4M DRAMs, or 8k bits if using 16M DRAMs.

VWA (valid write address)

The VWA is determined according to the YBLKCK pin and WAQV command. Refer to the timing chart below.

1. YBLKCK is a 75 Hz clock (HIGH for 136 μs) when used for normal read mode and it is a 150 Hz clock when used for double-speed read mode, synchronized to the CD format block end timing.

When this clock goes LOW, WA which is the write address of internal encode sequence, is stored (see note 2).

2. The microcontroller checks the subcode and, if confirmed to be correct, generates a WAQV command (80H).

3. When the WAQV command is received, the previously latched WA is stored as the VWA.

(note 2) Actually, there is a small time difference, or gap, between the input data and YBLKCK. This gap serves to preserve the preceding WA to protect against incorrect operation.

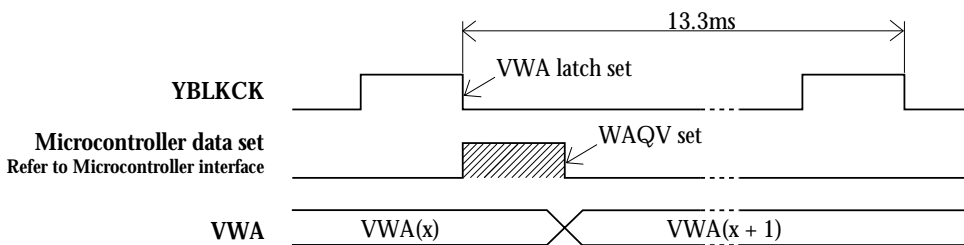

Values shown are for rate fs. The values are 1/2 those shown at rate 2fs.

Fig 2. YBLKCK and VWA relationship

YFLAG, YFCLK, FLAG6

Correct data demodulation becomes impossible for the CD signal processor IC when a disturbance exceeding the RAM jitter margin occurs. The YFLAG signal input pin is used to indicate when such a condition has occurred.

The YFCLK is a 7.35 kHz clock synchronized to the CD format frame 1.

The IC checks the YFLAG input and stops the

encode sequence when such a disturbance has occurred, and then makes FLAG6 active.

The YFLAG check method used changes depending on the YFLGS flag and YFCKP flag (85H command). See table1.

If YFLAGS is set to 1, then YFCLK should be tied either High or Low.

85H command			FLAG6 set conditions	FLAG6 reset conditions
	YFLGS	YFCKP		
1	0	0	When YFLAG=LOW on YFCLK input falling edge	- By status read (90H command) - When MSON=LOW - After system reset
2		1	When YFLAG=LOW on YFCLK input rising edge	
3	1	0	When YFLAG=LOW	
4		1	When YFLAG=HIGH	

Table 1. YFLAG signal check method

Compare-connect sequence

The SM5902AF supports three kinds of connect modes; 3-pair compare-connect, 2-pair compare-connect and direct connect.

Note that the SM5902AF can also operate in 12-bit comparison connect mode using only the most significant 12 bits of data for connection operation.

In 3-pair compare-connect mode, the final 6 valid data (3 pairs of left- and right-channel data input before encode processing) and the most recently input data are compared until three continuous data pairs all conform. At this point, the encode

sequence is re-started and data is written to VWA.

In 2-pair compare-connect mode, comparison occurs just as for 3-pair comparison except that only 2 pairs from the three compared need to conform with the valid data. At this point, the encode sequence is re-started and data is written to VWA.

In direct-connect mode, comparison is not performed at all, and encode sequence starts and data is written to the VWA. This mode is for systems that cannot perform compare-connect operation.

- Compare-connect preparation time

1. Comparison data preparation time

Internally, when the compare-connect start command is issued, a sequence starts to restore the data for comparison. The time required for this preparation after receiving the command is approximately $2.5 \times (1/f_s)$. (approximately 60 μ s when $f_s = 44.1$ kHz)

2. After the above preparation is finished, data is input beginning from the left-channel data and comparison starts.

3. If the compare-connect command is issued again, the preparation time above is not necessary and operation starts from step 2.

4. The same sequence takes place in direct-connect mode also. However, at the point when 3 words have been input, all data is directly connected as if comparison and conformance had taken place.

- Compare-connect sequence stop

If a compare-connect stop command (80H with MSDCN1= 1, MSDCN2= 0) is input from the micro-controller, compare-connect sequence stops.

If compare-connect sequence was not operating, the compare-connect stop command performs no operation. However, make sure that the other bit settings within the same 80H command are valid.

Encode sequence temporary stop

- When RAM becomes full, MSWREN is set LOW using the 80H command and encode sequence stops. (For details of the stop conditions, refer to the description of the ENCOD flag.)

- Then, if MSWREN is set HIGH without issuing a compare-connect start command, the encode sequence re-starts. At this time, new input data is written not to VWA, but to WA. In this way, the data already written to the region between VWA and WA is not lost.

- But if the MSWREN is set HIGH (80H command) after using the compare-connect start command even only once, data is written to VWA. If data is input before comparison and conformance is detected, the same operation as direct-connect mode takes place when the command is issued. After comparison and conformance are detected, no operation is performed because the encode sequence has already been started. However, make sure that the other bit settings within the same 80H command are valid.

DRAM refresh

- DRAM initialization refresh

A 15-cycle RAS-only refresh is carried out for DRAM initialization under the following conditions.

When MSON changes from 0 to 1 using command 80H.

When from MSON=1, MSRDEN=0 and MSWREN=0 states only MSWREN changes to 1. In this case, encode sequence immediately starts and initial data is written (at 2fs rate input) after a delay of 0.7ms.

- Refresh during Shock-proof mode operation

In this IC, a data access operation to any address also serves as a data refresh. Accordingly, there are no specific refresh cycles other than the initialization refresh cycle (described above).

This has the resulting effect of saving on DRAM power dissipation.

A data access to DRAM can occur in an encode sequence write operation or in a decode sequence read operation. Write sequence write operation stops during a connect operation whereas a read sequence read operation always continues while data is output to the D/A. The refresh rate for each DRAM during decode sequence is shown in the table below.

The decode sequence, set by MSON=1 and MSRDEN=1, operates when valid data is in DRAM (when MSEMP=0).

- When MSON=0, DRAM is not refreshed because no data is being accessed. Although MSON=1, DRAM is not refreshed if ENCOD=0 and DECOD=0 (both encode and decode sequence are stopped).

Data compression mode	DRAMs used (same for 1 or 2 DRAMs)		
	1M (256K×4 bits)	4M (1M×4 bits)	16M(4M×4 bits)
4 bit	5.44 ms	10.88 ms	21.77ms
5 bit	4.35 ms	8.71 ms	17.42ms
6 bit	3.63 ms	7.26 ms	14.52ms
Full bit	1.36 ms	2.72 ms	5.81ms

Table 2. Decode sequence refresh rate

Selecting compression mode

Even when the compression mode is selected with the 85H command during shock-proof operation, no malfunction occurs.

The compression mode change is not performed immediately after input of the 85H command, but it is performed at the following timing.

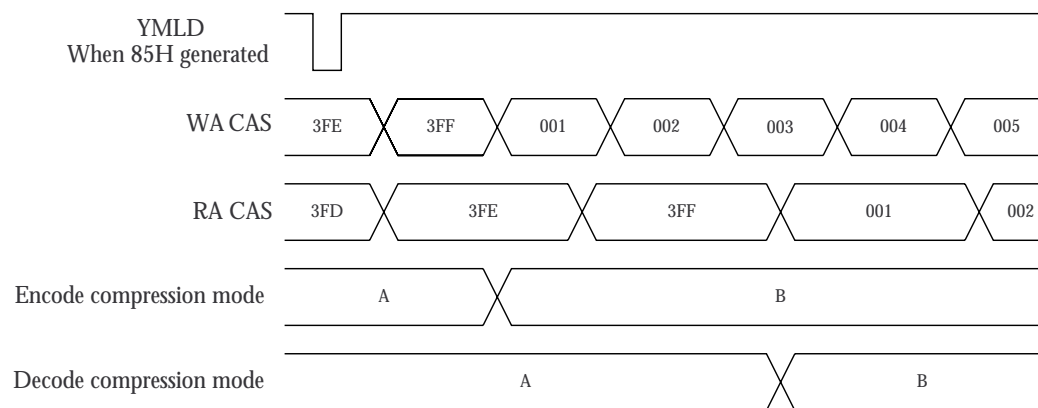

(note) CAS-000 is connect data.

Through-mode operation

If MSON is set LOW (80H command), an operating mode that does not perform shock-proof functions becomes active. In this case, input data is passed as-is (after attenuator and mute operations) to the output. External DRAM is not accessed.

- In this case, input data needs to be at a rate f_s and the input word clock must be synchronized to the CLK input ($384f_s$). However, short range jitter can be tolerated (jitter-free system).

- Jitter-free system timing starts from the first YLRCK rising edge after either (A) a reset (NRESET= 0) release by taking the reset input from LOW to HIGH or (B) by taking MSON from HIGH to LOW. Accordingly, to provide for the largest possible jitter margin, it is necessary that the YLRCK

clock be at rate f_s by the time jitter-free timing starts.

The jitter margin is $0.2/f_s$ (80 clock cycles).

This jitter margin is the allowable difference between the system clock (CLK) divided by 384 (f_s rate clock) and the YLRCK input clock.

If the timing difference exceeds the jitter margin, irregular operation like data being output twice or, conversely, incomplete data output may occur. In the worst case, a click noise may also be generated.

When switching from shock-proof mode to through mode, an output noise may be generated, and it is therefore recommended to use the YDMUTE setting to mute ZSRDATA until just before data output.

Attenuation

- The attenuation register is set by the 84H command.

- The attenuation register set value becomes active when the 83H command sets the ATT flag to 1.

When the ATT flag is 0, the attenuation register value is considered to be the equivalent of 256 for a maximum gain of 0 dB.

- The gain (dB) is given from the set value (Datt) by the following equation.

Gain = $20 \times \log(Datt/256)$ [dB]; left and right channels

- For the maximum attenuation register set value (Datt = 255), the corresponding gain is -0.03 dB. But when the ATT flag is 0 (Datt = 256), there is no attenuation.

- After a system reset initialization, the attenuation register is set to 64 (-12 dB). However, because the ATT flag is reset to 0, there is no attenuation.

- When the attenuation register setting changes or when the ATT flag changes, the gain changes smoothly from the previous set gain towards the new set value. If a new value for the attenuation level is set before the previously set level is reached, the gain changes smoothly towards the latest setting.

The gain changes at a rate of $4 \times (1/f_s)$ per step. A full-scale change (255 steps) takes approximately 23.3 ms (when $f_s = 44.1$ kHz). See fig 3.

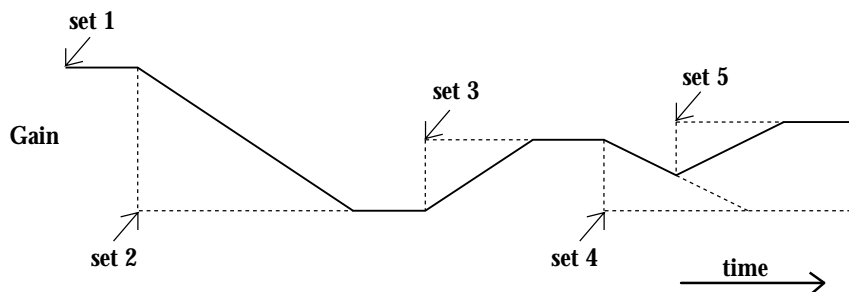

Fig 3. Attenuation operation example

Soft mute

Soft mute operation is controlled by the SOFT flag using a built-in attenuation counter.

Mute is ON when the SOFT flag is 1. When ON, the attenuation counter output decrement by 1 step at a time, thereby reducing the gain. Complete mute takes $1024/f_s$ (or approximately 23.2 ms for $f_s = 44.1$ kHz).

Conversely, mute is released when the SOFT flag is 0. In this case, the attenuation counter instantaneously increases. The attenuation register takes on the value when the ATT flag was 1. If the ATT flag was 0, the new set value is 256 (0 dB).

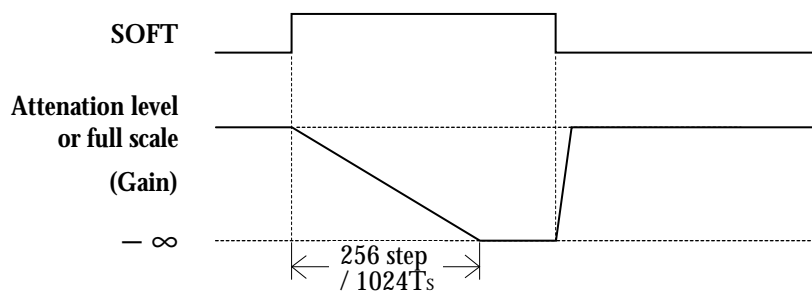

Fig 4. Soft mute operation example

Force mute

Serial output data is muted by setting the YDMUTE pin input HIGH or by setting the MUTE flag to 1. Mute starts and finishes on the leading left-channel bit.

When MSON is HIGH and valid data is empty (MSEMP=H), the output is automatically forced into the mute state.

12-bit comparison connection

When the CMP12 flag is set to 1, the least significant 4 bits of the 16-bit comparison connection input data are discarded and comparison connection is performed using the remaining 12 bits.

Note that if the CMP12 flag is set to 1 during a comparison connection operation, only the most significant 12 bits are used for comparison connection from that point on.

Digital audio interface

When the DIT flag is set to 1, the digital audio interface output from pin DIT is enabled. The output

data structure is modulated using a preamble and biphase mark encoding.

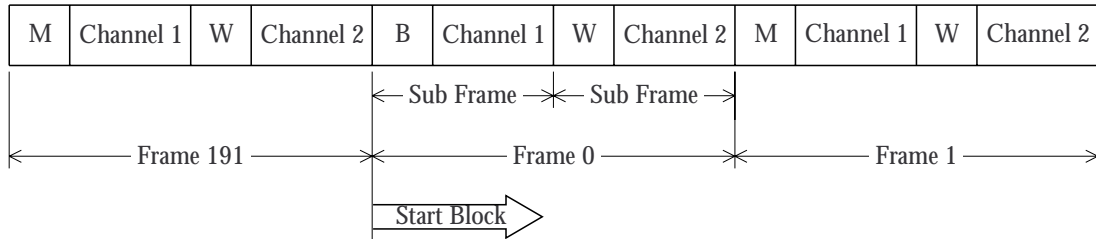

Figure 5. Frame format

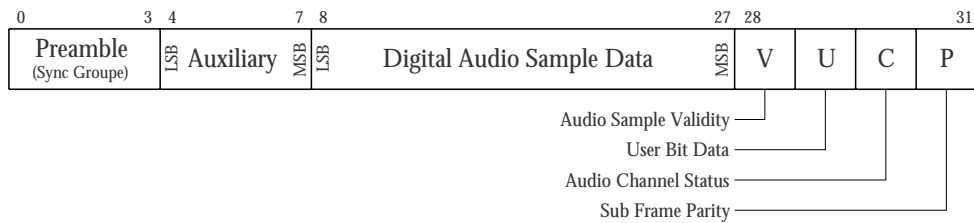

Figure 6. Subframe format

Preamble

The preamble is a particular bit pattern used to perform subframe and block synchronization and discrimination, assigned to one of 4 time slot divisions (0 to 3), comprising 8 continuous biphase modulated transfer rate status indicators.

There are 3 types of preamble. The leading preamble pattern of all blocks is preamble pattern B, which is then followed by preamble pattern M for channel 1, and preamble pattern W for channel 2.

Preamble	Channel coding	
	Leading symbol = 0	Leading symbol = 1
B	11101000	00010111
M	11100010	00011101
W	11100100	00011011

The SM5902AF starts with 0, so only the preamble patterns for leading symbol = 0 are used.

Digital audio sample data and auxiliary audio

The digital audio sample data is a 20-bit digitized audio signal. Auxiliary audio data, on the other hand, can be audio sample data of varying length.

The SM5902AF uses a 16-bit audio data structure internally with audio data output bits 4 to 11 set to 0 and bits 12 to 27 output in LSB first format.

Audio sample validity

The validity flag is set to 0 when the digital audio sample data is output correctly, or it is set to 1 if the output is incorrect. It is also set to 1 if encoding

does not start when the device is operating in forced mute, microcontroller forced mute, and shockproof mode.

User bit data

User bit data is data specified by the user. The data is output, after the Q data has been specified, in the following sequence.

	0	1	2	3	4	5	6	7	8	9	10	11
0	0	0	0	0	0	0	0	0	0	0	0	0
12	0	0	0	0	0	0	0	0	0	0	0	0
24	1	Q ₁	0	0	0	0	0	0	0	0	0	0
36	1	Q ₂	0	0	0	0	0	0	0	0	0	0
	•	•	•	•	•	•	•	•	•	•	•	•
1164	1	Q ₉₆	0	0	0	0	0	0	0	0	0	0

- Using Q data

Initially, Q₁ to Q₈₀ are set using the 87H command, the DIT flag is set using the 86H command, and then data is output from DIT according to the digital audio interface format. Q₈₁ to Q₉₆ data are not required as these are set internally by CRC calculation.

There are 2 Q data buffers; a data output buffer and a data storage buffer. As a result, after all data has been specified in the first data write, only that data that has changed needs to be written during the 2nd and subsequent data write operations. Note that address 1001 is the write stop command

and is, therefore, required after every data write operation.

When space becomes available in the data output buffer, QRDY is set to 1 (91H command status bit S3) to indicate available space and then the contents of the data storage buffer are transferred to the data output buffer. After data is transferred, a data write to address 1001 (write stop command) resets the QRDY flag to 0.

The Q data buffer read access time for a complete data cycle is approximately 13.3 ms.

Audio channel status

The channel status are information bits transferred to indicate the audio sample data length, preemphasis, sampling frequency, time code, source

number, destination code, and other information. Seven bits comprising CP1, CP2, LBIT, and CTL0 to CTL3 can be set. All other bits are fixed.

	0	1	2	3	4	5	6	7	8	9	10	11	12	13	14	15
0	CTL0	CTL1	CTL2	CTL3	0	0	0	0	1	0	0	0	0	0	0	LBIT
16	0	0	0	0	L=1	R=1	0	0	0	0	0	0	CP1	CP2	0	0
32	0	0	0	0	0	0	0	0	0	0	0	0	0	0	0	0
48	0	0	0	0	0	0	0	0	0	0	0	0	0	0	0	0
64	0	0	0	0	0	0	0	0	0	0	0	0	0	0	0	0
80	0	0	0	0	0	0	0	0	0	0	0	0	0	0	0	0
96	0	0	0	0	0	0	0	0	0	0	0	0	0	0	0	0
112	0	0	0	0	0	0	0	0	0	0	0	0	0	0	0	0
128	0	0	0	0	0	0	0	0	0	0	0	0	0	0	0	0
144	0	0	0	0	0	0	0	0	0	0	0	0	0	0	0	0
160	0	0	0	0	0	0	0	0	0	0	0	0	0	0	0	0
176	0	0	0	0	0	0	0	0	0	0	0	0	0	0	0	0

Subframe parity

The parity bit is used to indicate the detection of an odd number of bit errors. It is set to 1 if the number of 1s in the digital audio interface 27-bit data is odd,

and is set to 0 if the number of 1s is even. The 27-bit data plus parity bit form 28-bit data that always has an even number of 1s.

Timing charts

Input timing (YSCK, YSRDATA, YLRCK)

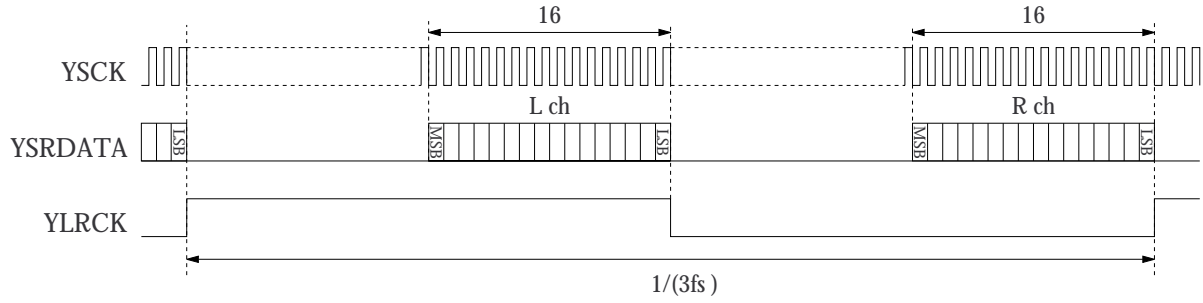

Output timing (ZSCK, ZSRDATA, ZLRCK)

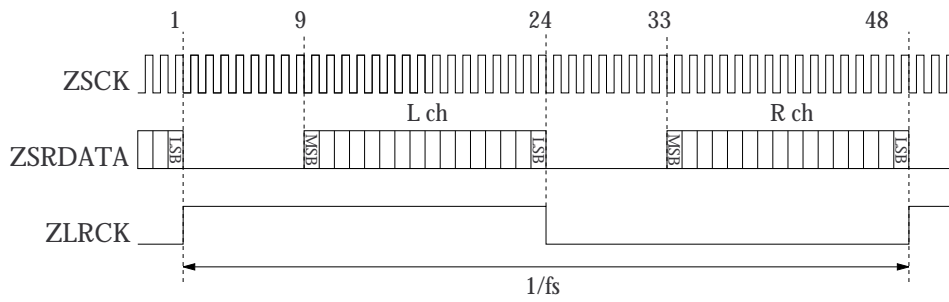

DRAM write timing (NRAS, NCAS, NCAS2, NWE, A0 to A10, D0 to D3)

Write timing (with single DRAM)

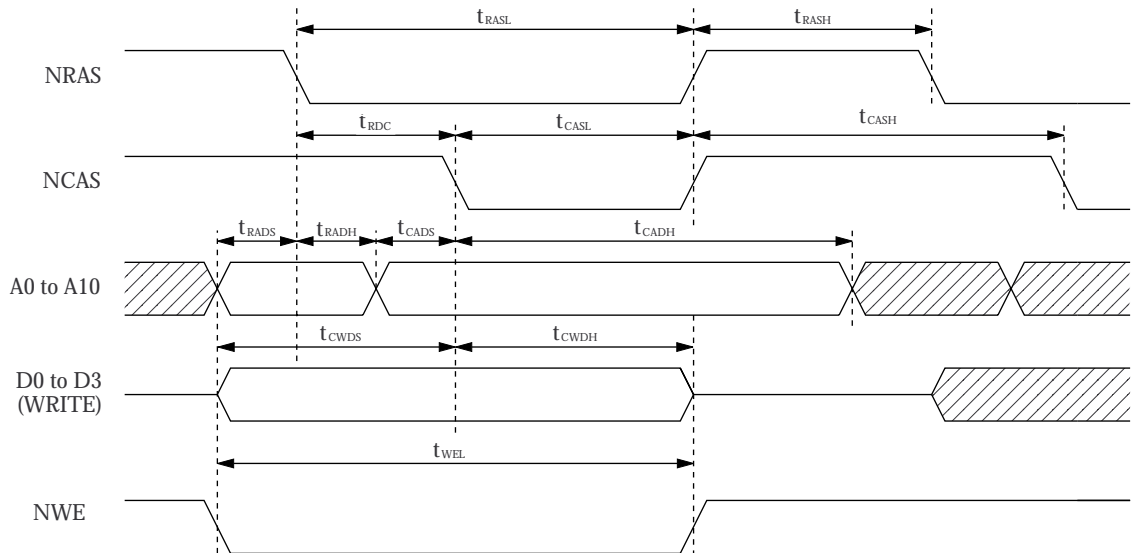

Write timing (with 2 DRAMs)

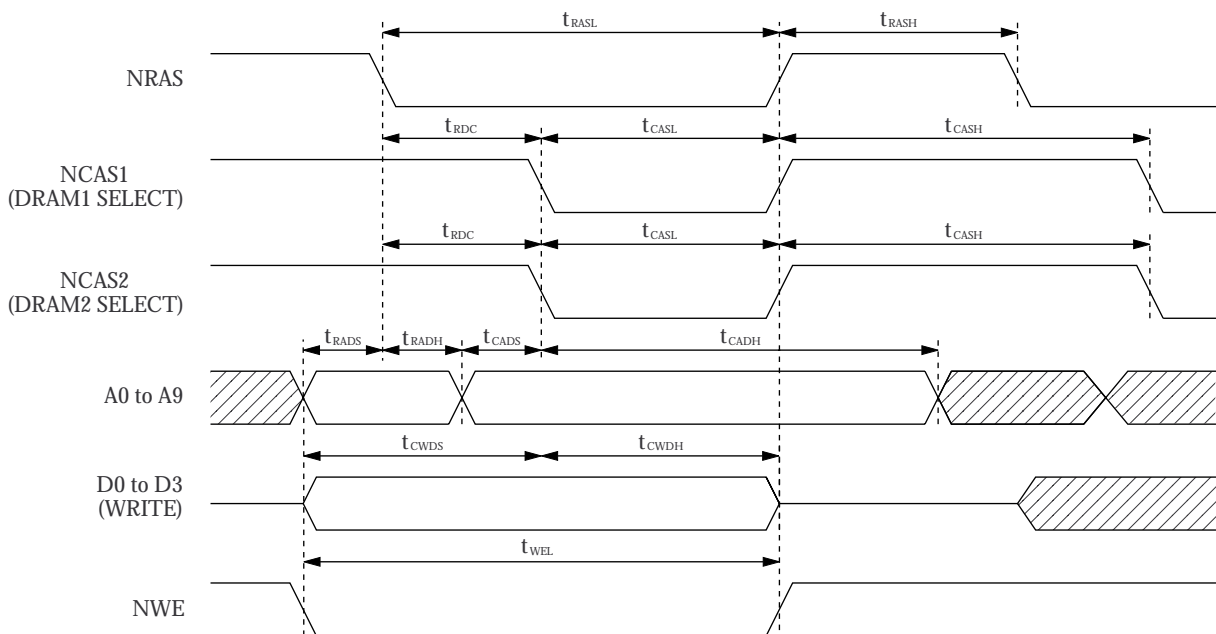

DRAM read timing (NRAS, NCAS, NCAS2, NWE, A0 to A10, D0 to D3)

Read timing (with single DRAM)

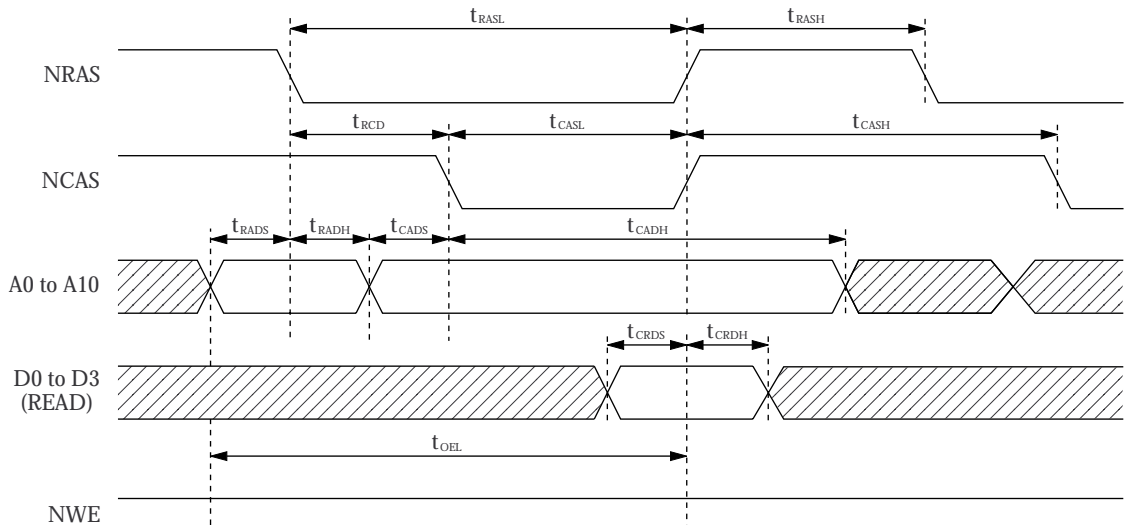

Read timing (with 2 DRAMs)

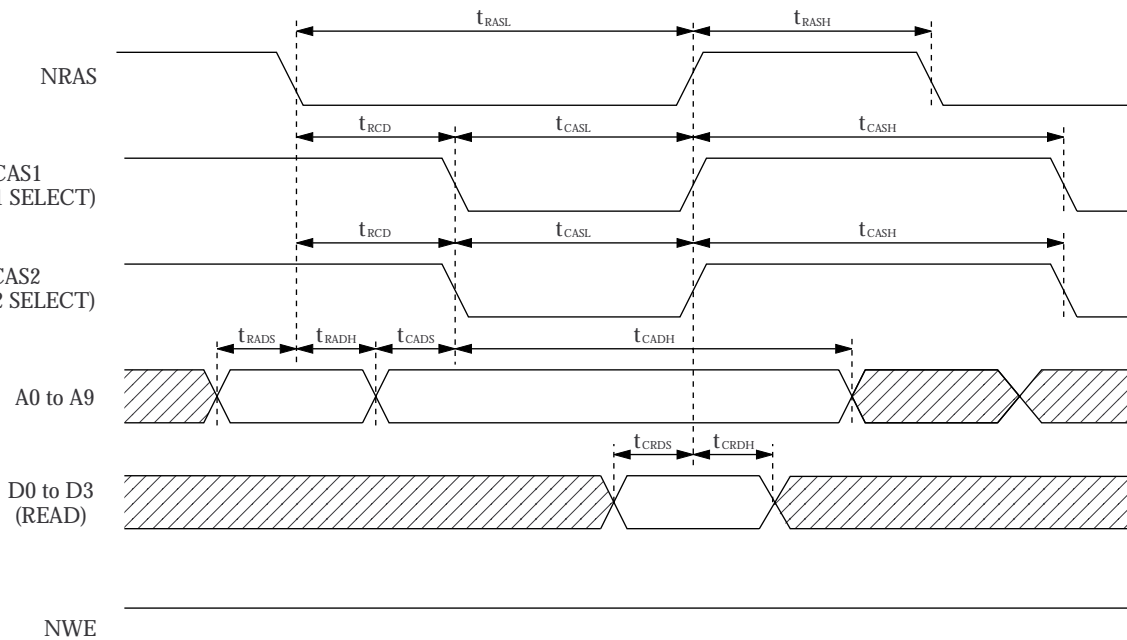

Connection example

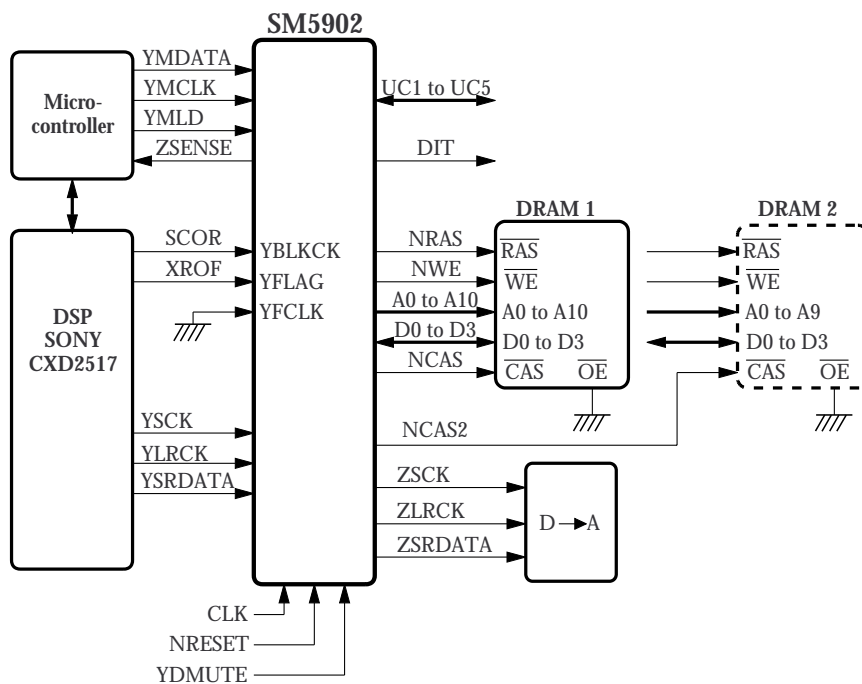
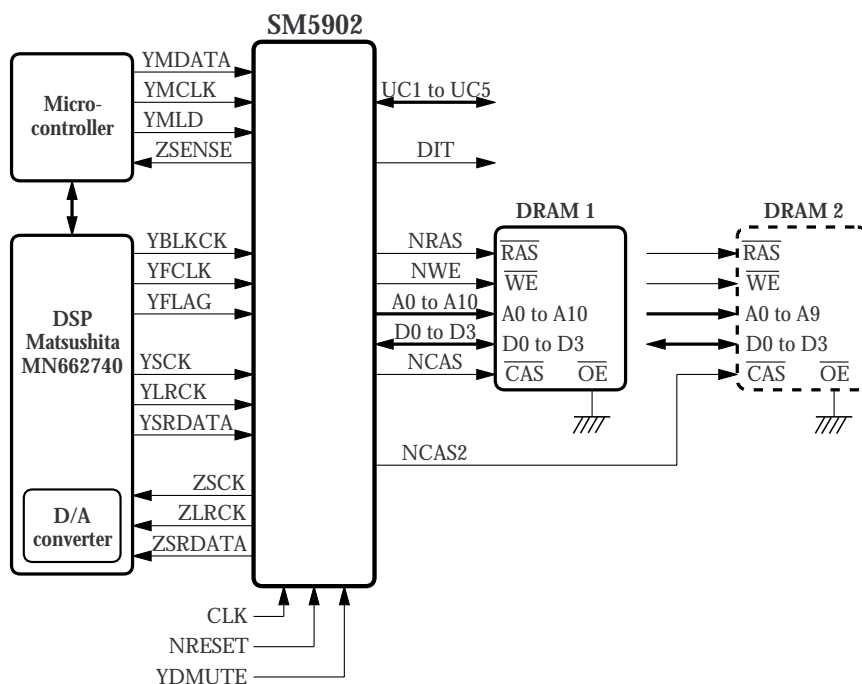

note1

- When 2 DRAMs are used, the DRAM \overline{OE} pins should be tied LOW.
- When single DRAM is used, the DRAM \overline{OE} pin should be tied LOW or controlled by the SM5902 NOE signal.

note 2 When CXD 2517 (Sony) is used

Set 85H of microcontroller command (option setting) as setting YFLAG take in;

D5: YFLAGS= 1

D4: YFCKP= 0

Device comparison with SM5856A1F

Pin differences

Pin No.	SM5856A1F	SM5902AF
1	VDD	VDD2
7	NTEST1	DIT
8	NTEST2	NTEST
22	UC6	VDD1
27	NOE / NCAS2	A10 / NCAS2

VDD pins

The SM5902AF operates from a 3 V supply voltage, but a built-in level shifter is provided for use with external 5 V DRAM ICs. There are, therefore, 2 supply pins. VDD1 is the internal 3 V IC supply, and

VDD2 is the external DRAM interface supply. If, however, the DRAM also operates from a 3 V supply, VDD1 and VDD2 can be connected to the same supply.

DIT pin

The SM5902AF incorporates a digital audio interface output from pin DIT. Leave open circuit if not used.

Microcontroller interface extensions

The SM5902AF supports additional function extensions. Also, the UC6 pin has been removed, which

means that UC6-related commands have been redefined.

Additional commands

Command	Bit	Name	Function
83H	D4	NS	Noise shaper ON/OFF switch
	D5	CMP12	12-bit comparison connection ON/OFF switch
86H	D4 to D7	CP1, 2, LBIT, DIT	Digital audio interface settings
87H	D0 to D11	QAD0 to 3, QD0 to 7	Subcode Q data settings
90H	S5	BOVF	Input buffer overflow
91H	S3	QRDY	Q data write buffer status

Modified commands

Command	Bit	Name	Function
85H	D6, D7	RAMS1, 2	External DRAM capacity
92H	S0 to 7, M1 to 8	AM06 to 21	Place of data residual

Obsolete commands

Command	Bit	Name	Function
81H	D5	UC6OE	UC6 input/output settings
82H	D5	UC6WD	UC6 output settings
93H	S5	UC6RD	UC6 settings status

Compression mode switching

The SM5902AF guarantees correct operation if the compression mode is switched, using the 85H com-

mand, during normal operation. However, all other settings should remain unchanged while switching.

Attenuation

The SM5902AF supports attenuation level adjustments in steps 1/4 of the minimum level for smooth

attenuation and soft muting.

16MDRAM

The SM5902AF can use with up to 16MDRAM.
(in case of SM5856A1F, up to 4M×2.)
So you can get a long shock-proof time.

Note that acceptable 16MDRAM is 2048-refresh type only. (Can not use with 4096-refresh type.)

NIPPON PRECISION CIRCUITS INC. reserves the right to make changes to the products described in this data sheet in order to improve the design or performance and to supply the best possible products. Nippon Precision Circuits Inc. assumes no responsibility for the use of any circuits shown in this data sheet, conveys no license under any patent or other rights, and makes no claim that the circuits are free from patent infringement. Applications for any devices shown in this data sheet are for illustration only and Nippon Precision Circuits Inc. makes no claim or warranty that such applications will be suitable for the use specified without further testing or modification. The products described in this data sheet are not intended to use for the apparatus which influence human lives due to the failure or malfunction of the products. Customers are requested to comply with applicable laws and regulations in effect now and hereinafter, including compliance with export controls on the distribution or dissemination of the products. Customers shall not export, directly or indirectly, any products without first obtaining required licenses and approvals from appropriate government agencies.



NIPPON PRECISION CIRCUITS INC.

4-3, FUKUZUMI 2 CHOME, KOTO-KU

TOKYO, 135-8430, JAPAN

Telephone: +81-3-3642-6661

Facsimile: +81-3-3642-6698