

OVERVIEW

The SM5022 series are crystal oscillator module ICs fabricated in NPC's Molybdenum-gate CMOS, that incorporate high-frequency, low current consumption oscillator and output buffer circuits. Feedback resistors and high-frequency capacitors are built-in, eliminating the need for external components to make a stable fundamental oscillator.

FEATURES

- Up to 30MHz operating frequency range (fundamental oscillation)
- Oscillator capacitors C_G , C_D built-in (excluding A2A, A4A)
- Inverter amplifier feedback resistor built-in
- TTL input level
- Output drive capability
 - 4mA ($V_{DD} = 2.7V$)
 - 8mA ($V_{DD} = 4.5V$)
- Output three-state function
- Operating supply voltage range
 - 2.7 to 5.5V (AxA series)
 - 4.5 to 5.5V (BxA series)
- f_O , $f_O/2$, $f_O/4$, $f_O/8$ output frequency, determined by internal connection
- 6-pin SOT (SM5022xAH)
- Chip form (CF5022xA)

SERIES CONFIGURATION

Version ^{*1}	Operating supply voltage range [V]		Recommended operating frequency range ^{*2} [MHz]		Built-in capacitance [pF]		gm ratio	Rf [kΩ]	Output frequency	Output level	Standby mode	
	Chip	SOT	3V operation	5V operation	C_G	C_D					Oscillator stop function	Output state
SM5022A1AH	2.7 to 5.5	2.7 to 5.5	4 to 24	4 to 30	8	10	1	600	fo	CMOS	Yes	Hi-Z
SM5022A2AH					-	-			fo			
SM5022A3AH			8		10	fo/2						
SM5022A4AH			-		-	fo/2						
SM5022A5AH			8		10	fo/4						
SM5022A7AH			8		10	fo/8						
SM5022B1AH	4.5 to 5.5	4.5 to 5.5	×	4 to 30	8	10	1	600	fo	TTL	Yes	Hi-Z

*1. Chip form devices have designation CF5022xA.

*2. The recommended operating frequency is a yardstick value derived from the crystal used for NPC characteristics authentication. However, the oscillator frequency band is not guaranteed. Specifically, the characteristics can vary greatly due to crystal characteristics and mounting conditions, so the oscillation characteristics of components must be carefully evaluated.

ORDERING INFORMATION

Device	Package
SM5022xAH	SOT23-6
CF5022xA-2	Chip form

PAD LAYOUT

(Unit: μm)

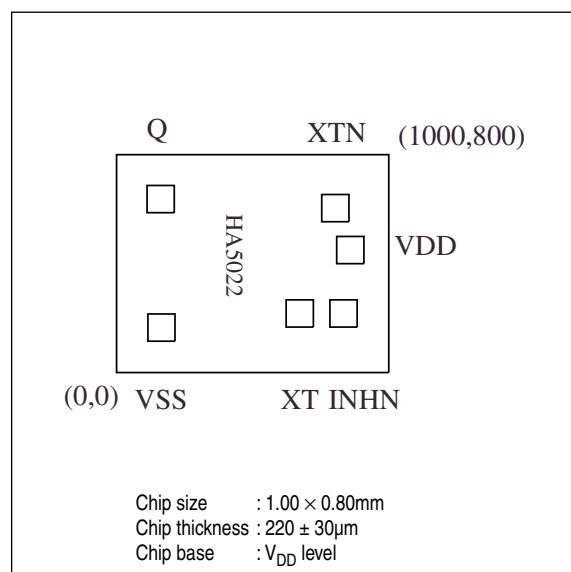

PINOUT

(Top view)

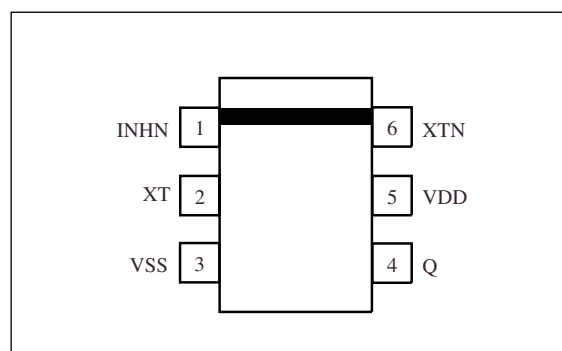

Version	Product ID
SM5022A1AH	A00
SM5022A2AH	A01
SM5022A3AH	A02
SM5022A4AH	A03
SM5022A5AH	A04
SM5022A7AH	A05
SM5022B1AH	A06

PIN DESCRIPTION and PAD DIMENSIONS

Number	Name	I/O	Description	Pad dimensions [μm]	
				X	Y
1	INH N	I	Output state control input. High impedance when LOW. Pull-up resistor built in	834	217
2	XT	I	Amplifier input. Crystal oscillator connection pins. Crystal oscillator is connected between XT and XTN	637	217
3	VSS	-	Ground	165	165
4	Q	O	Output. Output frequency (f_O , $f_O/2$, $f_O/4$, $f_O/8$) determined by internal connection	162	637
5	VDD	-	Supply voltage	859	450
6	XTN	O	Amplifier output. Crystal oscillator connection pins. Crystal oscillator is connected between XT and XTN	804	604

PACKAGE DIMENSIONS

(Unit: mm)

- 6-pin SOT

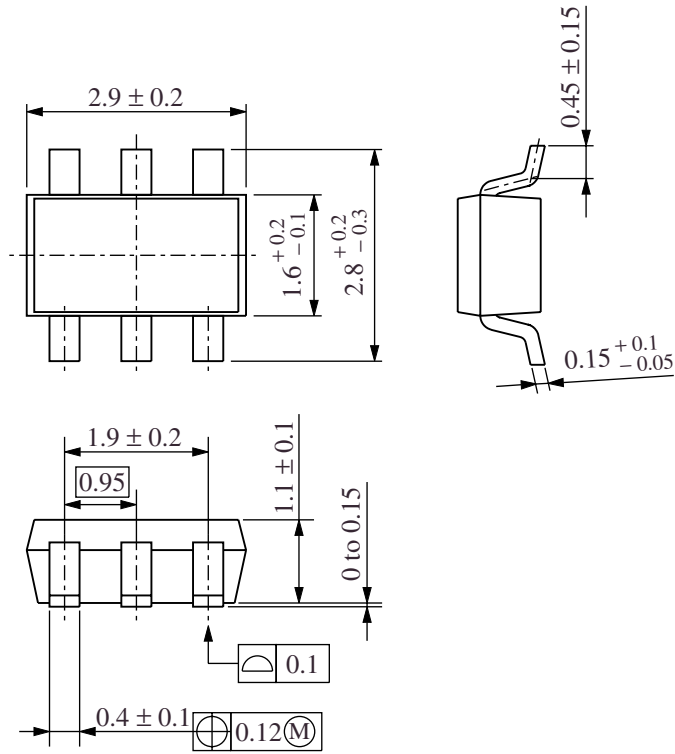

BLOCK DIAGRAM

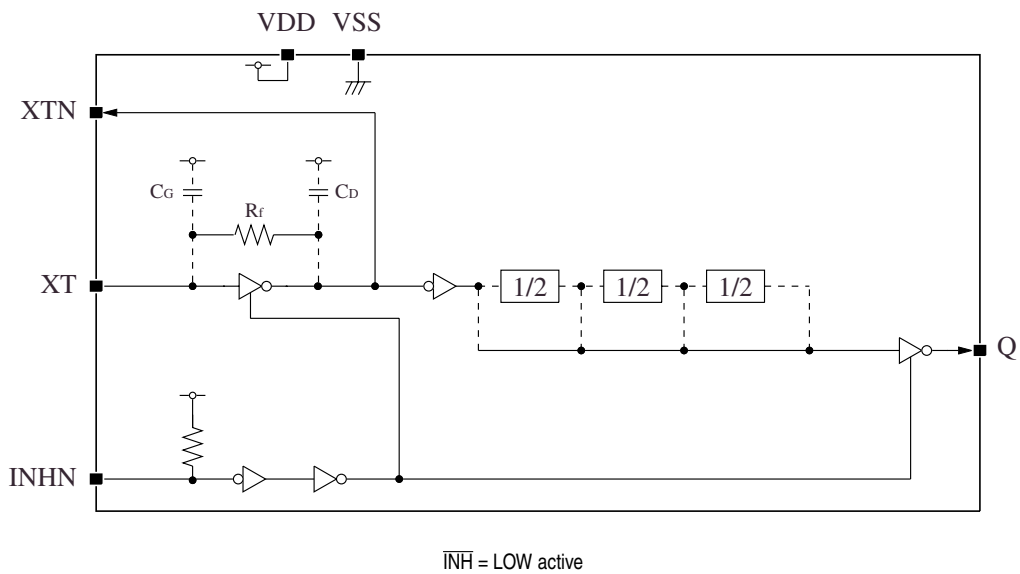

SPECIFICATIONS

Absolute Maximum Ratings

$$V_{SS} = 0V$$

Parameter	Symbol	Condition	Rating	Unit
Supply voltage range	V_{DD}		- 0.5 to + 7.0	V
Input voltage range	V_{IN}		- 0.5 to $V_{DD} + 0.5$	V
Output voltage range	V_{OUT}		- 0.5 to $V_{DD} + 0.5$	V
Operating temperature range	T_{opr}		- 40 to + 85	°C
Storage temperature range	T_{stg}	Chip form	- 65 to + 150	°C
		SOT23-6	- 55 to + 125	
Output current	I_{OUT}		13	mA
Power dissipation	P_D	SOT23-6	250	mW

Recommended Operating Conditions

3V operation: A×A series

$$V_{SS} = 0V, f \leq 30MHz, C_L \leq 15pF$$

Parameter	Symbol	Condition	Rating			Unit
			min	typ	max	
Supply voltage	V_{DD}		2.7	-	3.6	V
Input voltage	V_{IN}		V_{SS}	-	V_{DD}	V
Operating temperature	T_{OPR}		- 20	-	+ 80	°C

5V operation: A×A series/ B×A series

$$V_{SS} = 0V, f \leq 30MHz, C_L \leq 15pF$$

Parameter	Symbol	Condition	Rating			Unit
			min	typ	max	
Supply voltage	V_{DD}		4.5	-	5.5	V
Input voltage	V_{IN}		V_{SS}	-	V_{DD}	V
Operating temperature	T_{OPR}		- 20	-	+ 80	°C

Electrical Characteristics

3V operation: A×A series

$V_{DD} = 2.7$ to $3.6V$, $V_{SS} = 0V$, $T_a = -20$ to $+80^{\circ}C$ unless otherwise noted.

Parameter	Symbol	Condition	Rating			Unit	
			min	typ	max		
HIGH-level output voltage	V_{OH}	Q: Measurement cct 1, $V_{DD} = 2.7V$, $I_{OH} = 4mA$	2.1	2.4	–	V	
LOW-level output voltage	V_{OL}	Q: Measurement cct 2, $V_{DD} = 2.7V$, $I_{OL} = 4mA$	–	0.3	0.4	V	
HIGH-level input voltage	V_{IH}	INH N	2.0	–	–	V	
LOW-level input voltage	V_{IL}	INH N	–	–	0.5	V	
Output leakage current	I_Z	Q: Measurement cct 2, $V_{DD} = 3.6V$, INHN = LOW, $V_{OH} = V_{DD}$	–	–	10	μA	
		Q: Measurement cct 2, $V_{DD} = 3.6V$, INHN = LOW, $V_{OL} = V_{SS}$	–	–	10		
Current consumption	I_{DD}	30MHz crystal oscillator, measurement cct 3, load cct 1, INHN = open, $C_L = 15pF$	–	4	7	mA	
INH N pull-up resistance	R_{UP}	Measurement cct 4	25	100	250	$k\Omega$	
Feedback resistance	R_f	Measurement cct 5	200	600	1000	$k\Omega$	
Built-in capacitance	C_G	Design value. A monitor pattern on a wafer is tested.	SM5022A1AH, CF5022A1A SM5022A3AH, CF5022A3A SM5022A5AH, CF5022A5A SM5022A7AH, CF5022A7A	7.44	8	8.56	pF
	C_D			9.3	10	10.7	pF

5V operation: A×A, B×A series

$V_{DD} = 4.5$ to $5.5V$, $V_{SS} = 0V$, $T_a = -20$ to $+80^{\circ}C$ unless otherwise noted.

Parameter	Symbol	Condition	Rating			Unit	
			min	typ	max		
HIGH-level output voltage	V_{OH}	Q: Measurement cct 1, $V_{DD} = 4.5V$, $I_{OH} = 8mA$	3.9	4.2	–	V	
LOW-level output voltage	V_{OL}	Q: Measurement cct 2, $V_{DD} = 4.5V$, $I_{OL} = 8mA$	–	0.3	0.4	V	
HIGH-level input voltage	V_{IH}	INH N	2.0	–	–	V	
LOW-level input voltage	V_{IL}	INH N	–	–	0.8	V	
Output leakage current	I_Z	Q: Measurement cct 2, $V_{DD} = 5.5V$, INHN = LOW, $V_{OH} = V_{DD}$	–	–	10	μA	
		Q: Measurement cct 2, $V_{DD} = 5.5V$, INHN = LOW, $V_{OL} = V_{SS}$	–	–	10		
Current consumption	I_{DD}	30MHz crystal oscillator, measurement cct 3, load cct 1, INHN = open, $C_L = 15pF$	SM5022A×AH, CF5022A×A	–	7	12	mA
		30MHz crystal oscillator, measurement cct 3, load cct 2, INHN = open, $C_L = 15pF$	SM5022B×AH, CF5022B×A	–	7	12	
INH N pull-up resistance	R_{UP}	Measurement cct 4	25	100	250	$k\Omega$	
Feedback resistance	R_f	Measurement cct 5	200	600	1000	$k\Omega$	
Built-in capacitance	C_G	Design value. A monitor pattern on a wafer is tested.	SM5022A1AH, CF5022A1A SM5022A3AH, CF5022A3A SM5022A5AH, CF5022A5A SM5022A7AH, CF5022A7A SM5022B1AH, CF5022B1A	7.44	8	8.56	pF
	C_D			9.3	10	10.7	pF

Switching Characteristics

CMOS Output Version: AxA series

3V operation

$V_{DD} = 2.7$ to $3.6V$, $V_{SS} = 0V$, $T_a = -20$ to $+80^{\circ}C$ unless otherwise noted.

Parameter	Symbol	Condition	Rating			Unit	
			min	typ	max		
Output rise time	t_{r1}	Measurement cct 6, load cct 1, $C_L = 15pF$	$0.2V_{DD}$ to $0.8V_{DD}$	–	5	10	ns
			$0.1V_{DD}$ to $0.9V_{DD}$	–	10	20	
Output fall time	t_{f1}	Measurement cct 6, load cct 1, $C_L = 15pF$	$0.8V_{DD}$ to $0.2V_{DD}$	–	5	10	ns
			$0.9V_{DD}$ to $0.1V_{DD}$	–	10	20	
Output duty cycle ^{*1}	Duty	Measurement cct 6, load cct 1, $V_{DD} = 3V$, $T_a = 25^{\circ}C$, $C_L = 15pF$, $f = 30MHz$	45	–	55	%	
Output disable delay time ^{*2}	t_{PLZ}	Measurement cct 7, load cct 1, $V_{DD} = 3V$, $T_a = 25^{\circ}C$, $C_L = 15pF$	–	–	100	ns	
Output enable delay time ^{*2}	t_{PZL}		–	–	100	ns	

*1. The duty cycle characteristic is checked the sample chips of each production lot.

*2. Oscillator stop function is built-in. When INHN goes LOW, normal output stops. When INHN goes HIGH, normal output is not resumed until after the oscillator start-up time has elapsed.

5V operation

$V_{DD} = 4.5$ to $5.5V$, $V_{SS} = 0V$, $T_a = -20$ to $+80^{\circ}C$ unless otherwise noted.

Parameter	Symbol	Condition	Rating			Unit
			min	typ	max	
Output rise time	t_{r2}	Measurement cct 6, load cct 1, $0.1V_{DD}$ to $0.9V_{DD}$, $C_L = 15pF$	–	3.5	7	ns
Output fall time	t_{f2}	Measurement cct 6, load cct 1, $0.9V_{DD}$ to $0.1V_{DD}$, $C_L = 15pF$	–	3.5	7	ns
Output duty cycle ^{*1}	Duty	Measurement cct 6, load cct 1, $V_{DD} = 5V$, $T_a = 25^{\circ}C$, $C_L = 15pF$, $f = 30MHz$	45	–	55	%
Output disable delay time ^{*2}	t_{PLZ}	Measurement cct 7, load cct 1, $V_{DD} = 5V$, $T_a = 25^{\circ}C$, $C_L = 15pF$	–	–	100	ns
Output enable delay time ^{*2}	t_{PZL}		–	–	100	ns

*1. The duty cycle characteristic is checked the sample chips of each production lot.

*2. Oscillator stop function is built-in. When INHN goes LOW, normal output stops. When INHN goes HIGH, normal output is not resumed until after the oscillator start-up time has elapsed.

TTL Output Version: BxA series**5V operation**

$V_{DD} = 4.5$ to $5.5V$, $V_{SS} = 0V$, $T_a = -20$ to $+80^{\circ}C$ unless otherwise noted.

Parameter	Symbol	Condition	Rating			Unit
			min	typ	max	
Output rise time	t_{r3}	Measurement cct 6, load cct 2, 0.4V to 2.4V, $C_L = 15pF$	–	2.5	7	ns
Output fall time	t_{f3}	Measurement cct 6, load cct 2, 2.4V to 0.4V, $C_L = 15pF$	–	2.5	7	ns
Output duty cycle ^{*1}	Duty	Measurement cct 6, load cct 2, $V_{DD} = 5V$, $T_a = 25^{\circ}C$, $C_L = 15pF$, $f = 30MHz$	45	–	55	%
Output disable delay time ^{*2}	t_{PLZ}	Measurement cct 7, load cct 2, $V_{DD} = 5V$, $T_a = 25^{\circ}C$, $C_L = 15pF$	–	–	100	ns
Output enable delay time ^{*2}	t_{PZL}		–	–	100	ns

*1. The duty cycle characteristic is checked the sample chips of each production lot.

*2. Oscillator stop function is built-in. When INHN goes LOW, normal output stops. When INHN goes HIGH, normal output is not resumed until after the oscillator start-up time has elapsed.

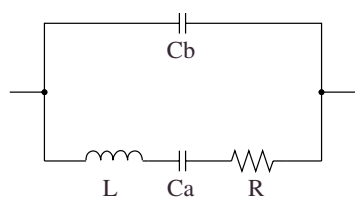
Current consumption and Output waveform with NPC's standard crystal

f [MHz]	R [Ω]	L [mH]	Ca [fF]	Cb [pF]
30	17.2	4.36	6.46	2.26

FUNCTIONAL DESCRIPTION**Standby Function**

When INHN goes LOW, the oscillator output on Q goes high impedance.

INHN	Q	Oscillator
HIGH (or open)	Any f_O , $f_O/2$, $f_O/4$, or $f_O/8$ output frequency	Normal operation
LOW	High impedance	Stopped

MEASUREMENT CIRCUITS

Measurement cct 1

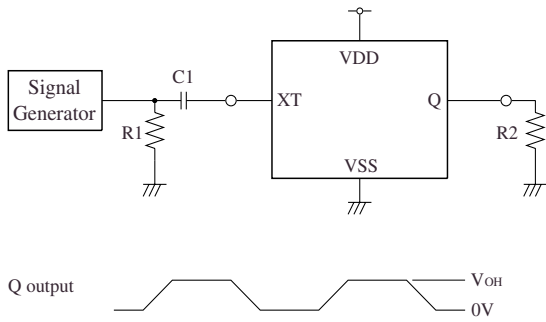

2.0Vp-p, 10MHz sine wave input signal (3V operation)
 3.5Vp-p, 10MHz sine wave input signal (5V operation)
 C1: 0.001μF
 R1: 50Ω
 R2: 525Ω (3V operation)
 490Ω (5V operation)

Measurement cct 4

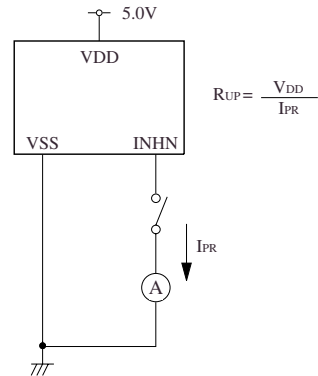

Measurement cct 5

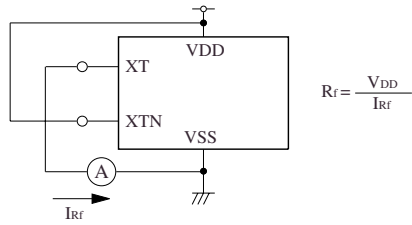

Measurement cct 2

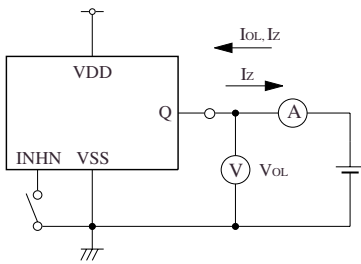

Measurement cct 6

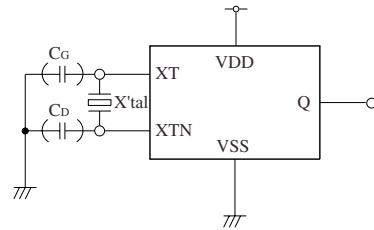

C_G, C_D: 10pF (5022A2, 5022A4)

Measurement cct 3

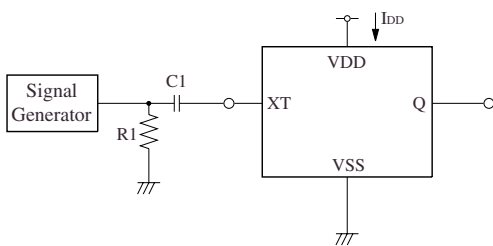

2.0Vp-p, 30MHz sine wave input signal (3V operation)
 3.5Vp-p, 30MHz sine wave input signal (5V operation)
 C1: 0.001μF
 R1: 50Ω

Measurement cct 7

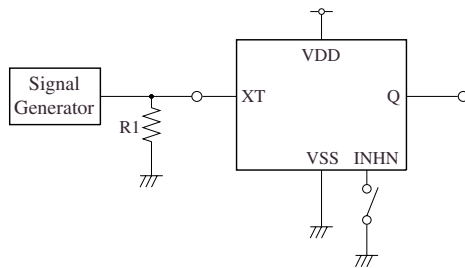

R1: 50Ω

Load cct 1

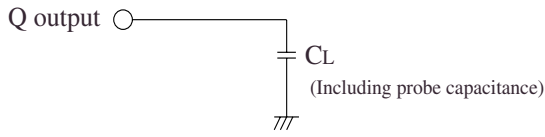

$C_L = 15\text{pF}$

Load cct 2

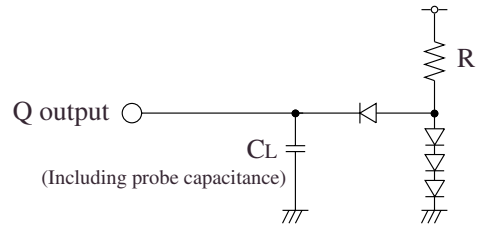

$C_L = 15\text{pF}$
 $R = 800\Omega$

Switching Time Measurement Waveform

Output duty level (CMOS)

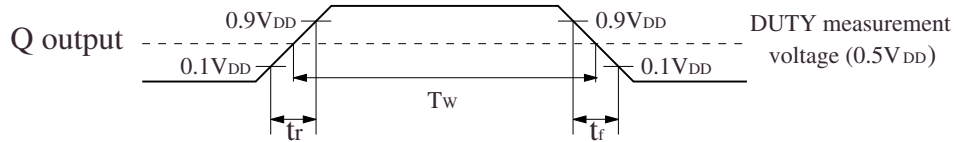

Output duty level (TTL)

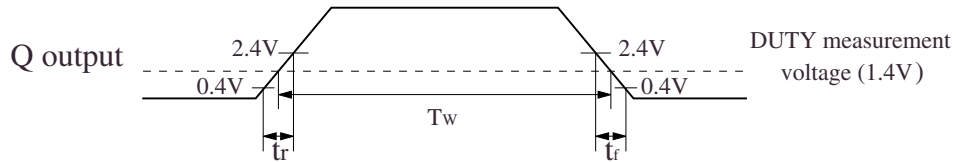

Output duty cycle (CMOS)

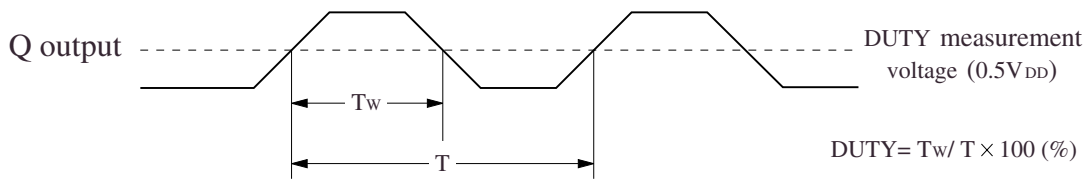

Output duty cycle (TTL)

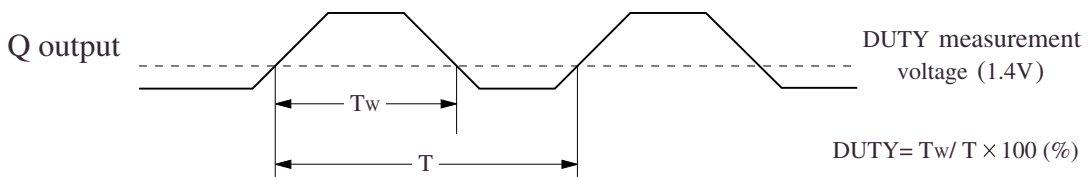

Output Enable/Disable Delay

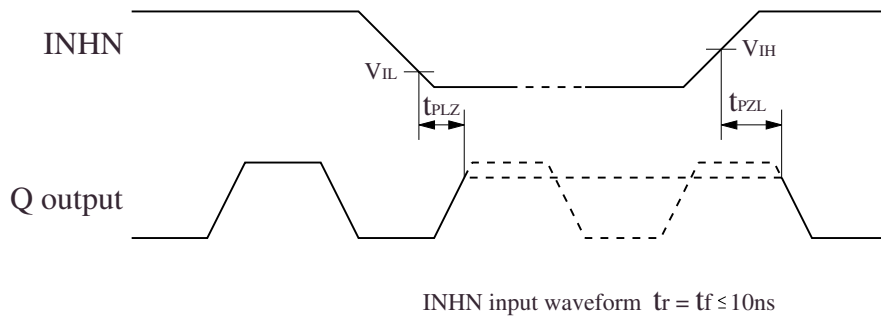

Please pay your attention to the following points at time of using the products shown in this document.

The products shown in this document (hereinafter "Products") are not intended to be used for the apparatus that exerts harmful influence on human lives due to the defects, failure or malfunction of the Products. Customers are requested to obtain prior written agreement for such use from SEIKO NPC CORPORATION (hereinafter "NPC"). Customers shall be solely responsible for, and indemnify and hold NPC free and harmless from, any and all claims, damages, losses, expenses or lawsuits, due to such use without such agreement. NPC reserves the right to change the specifications of the Products in order to improve the characteristic or reliability thereof. NPC makes no claim or warranty that the contents described in this document dose not infringe any intellectual property right or other similar right owned by third parties. Therefore, NPC shall not be responsible for such problems, even if the use is in accordance with the descriptions provided in this document. Any descriptions including applications, circuits, and the parameters of the Products in this document are for reference to use the Products, and shall not be guaranteed free from defect, inapplicability to the design for the mass-production products without further testing or modification. Customers are requested not to export or re-export, directly or indirectly, the Products to any country or any entity not in compliance with or in violation of the national export administration laws, treaties, orders and regulations. Customers are requested appropriately take steps to obtain required permissions or approvals from appropriate government agencies.

The logo for NPC (Seiko NPC Corporation) consists of the letters 'NPC' in a bold, black, sans-serif font. The 'N' and 'P' are connected at the top, and the 'C' is positioned to the right of the 'P'.

SEIKO NPC CORPORATION

15-6, Nihombashi-kabutocho, Chuo-ku,
Tokyo 103-0026, Japan
Telephone: +81-3-6667-6601
Facsimile: +81-3-6667-6611
<http://www.npc.co.jp/>
Email: sales@npc.co.jp

NC9906CE 2006.04