

### OVERVIEW

The SM5005A series are crystal oscillator module ICs, that incorporate high-frequency, low current consumption oscillator and output buffer circuits. Highly accurate thin-film feedback resistors and high-frequency capacitors are built-in, eliminating the need for external components to make a stable 3rd overtone oscillator.

### FEATURES

- High-frequency operation
- 3rd overtone oscillation
- Capacitors  $C_G$ ,  $C_D$  built-in
- Standby function (oscillator stops)
- Power-saving pull-up resistor built-in
- Inverter amplifier feedback resistor built-in
- CMOS input level
- 8mA ( $V_{DD} = 2.7V$ ) drive capability
- CMOS output duty level
- Output three-state function
- 2.25 to 3.6V supply voltage
- Oscillator frequency output
- 8-pin VSOP (SM5005A××V)
- Chip form (CF5005A××)

### SERIES CONFIGURATION

Version <sup>1</sup>	Recommended operating frequency range <sup>2</sup> [MHz]		gm ratio	Output duty level	Output current [mA]	Built-in capacitance [pF]		$R_f$ [kΩ]
	$V_{DD} = 2.25$ to 2.75V	$V_{DD} = 2.7$ to 3.6V				$C_G$	$C_D$	
SM5005ALAV	60 to 70	70 to 100	1.0	CMOS	8	8	10	2.2
SM5005ALBV	–	90 to 110	1.5	CMOS	8	6	6	3.3
SM5005ALCV	–	107 to 125	1.5	CMOS	8	3	3	3.3
CF5005ALD <sup>3</sup>	45 to 60	60 to 80	1.0	CMOS	8	8	10	3.5
CF5005ALE <sup>3</sup>	30 to 45	40 to 60	1.0	CMOS	8	8	15	5.6

1. Chip form devices have designation CF5005A××.

2. The recommended operating frequency is a yardstick value derived from the crystal used for NPC characteristics authentication. However, the oscillator frequency band is not guaranteed. Specifically, the characteristics can vary greatly due to crystal characteristics and mounting conditions, so the oscillation characteristics of components must be carefully evaluated.

3. Chip form only.

### ORDERING INFORMATION

Device	Package
SM5005A××V	8-pin VSOP
CF5005A××-1	Chip form

**PACKAGE DIMENSIONS**

(Unit: mm)

- 8-pin VSOP

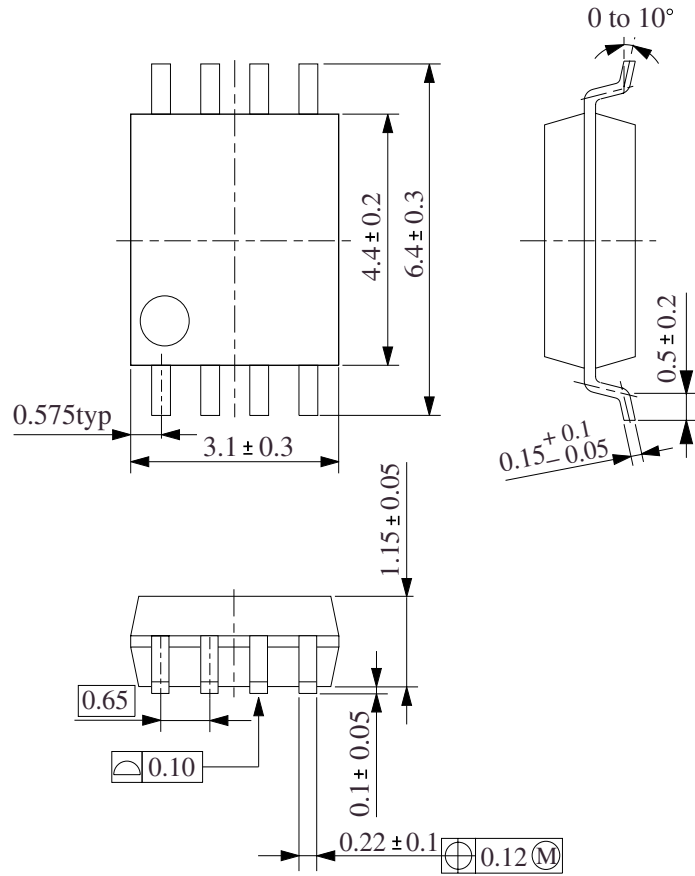

**PAD LAYOUT**

(Unit:  $\mu\text{m}$ )

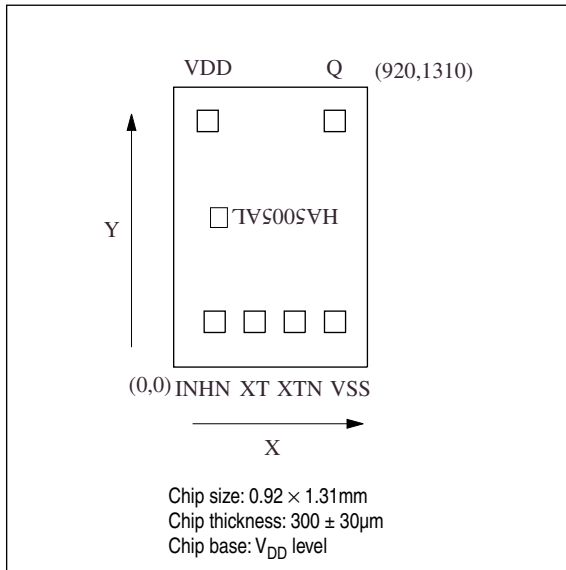

**PINOUT**

(Top view)

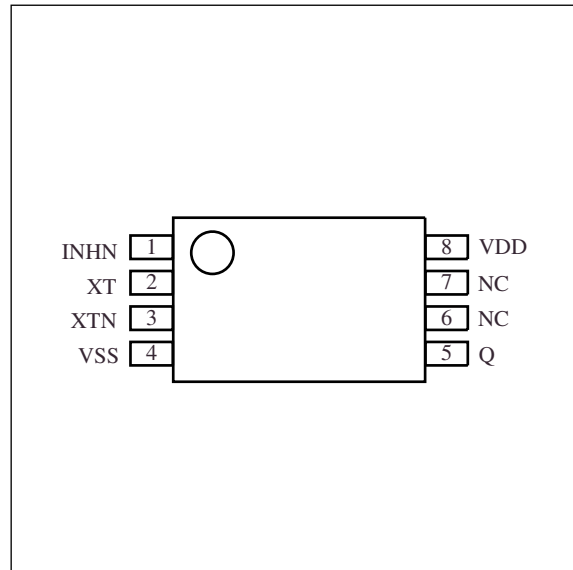

**PIN DESCRIPTION and PAD DIMENSIONS**

Number	Name	I/O	Description	Pad dimensions [ $\mu\text{m}$ ]	
				X	Y
1	INHN	I	Output state control input. Oscillator stopped when LOW. Power-saving pull-up resistor built in	195	212
2	XT	I	Amplifier input.	385	212
3	XTN	O	Amplifier output.	575	212
4	VSS	-	Ground	766	212
5	Q	O	Output. Output frequency ( $f_0$ )	765	1152
6	NC	-	No connection	-	-
7	NC	-	No connection	-	-
8	VDD	-	Supply voltage	162	1152

**BLOCK DIAGRAM**

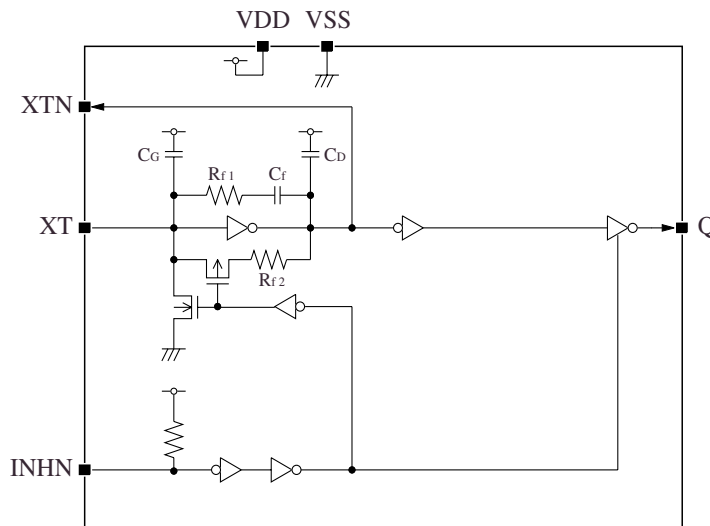

## SPECIFICATIONS

### Absolute Maximum Ratings

$V_{SS} = 0V$

Parameter	Symbol	Condition	Rating	Unit
Supply voltage range	$V_{DD}$		-0.5 to 7.0	V
Input voltage range	$V_{IN}$		-0.5 to $V_{DD} + 0.5$	V
Output voltage range	$V_{OUT}$		-0.5 to $V_{DD} + 0.5$	V
Operating temperature range	$T_{opr}$		-40 to 85	°C
Storage temperature range	$T_{stg}$	Chip form	-65 to 150	°C
		8-pin VSOP	-40 to 125	
Output current	$I_{OUT}$		25	mA
Power dissipation	$P_D$	8-pin VSOP	300	mW

### Recommended Operating Conditions

#### CF5005AL×

$V_{SS} = 0V$ ,  $f \leq 125MHz$  unless otherwise noted.

Parameter	Symbol	Condition	Rating			Unit
			min	typ	max	
Supply voltage	$V_{DD}$	$C_L \leq 15pF$	2.7	-	3.6	V
		$C_L \leq 30pF$	3.0	-	3.6	
Input voltage	$V_{IN}$		$V_{SS}$	-	$V_{DD}$	V
Operating temperature	$T_{OPR}$		-20	-	80	°C

#### CF5005ALA/CF5005ALD/CF5005ALE

$V_{SS} = 0V$ ,  $f \leq 70MHz$  unless otherwise noted.

Parameter	Symbol	Condition	Rating			Unit
			min	typ	max	
Supply voltage	$V_{DD}$	$C_L \leq 30pF$	2.25	-	2.75	V
Input voltage	$V_{IN}$		$V_{SS}$	-	$V_{DD}$	V
Operating temperature	$T_{OPR}$		-20	-	80	°C

#### SM5005AL×V

$V_{SS} = 0V$ ,  $f \leq 125MHz$  unless otherwise noted.

Parameter	Symbol	Condition	Rating			Unit
			min	typ	max	
Supply voltage	$V_{DD}$	$C_L \leq 15pF$	2.7	-	3.6	V
Input voltage	$V_{IN}$		$V_{SS}$	-	$V_{DD}$	V
Operating temperature	$T_{OPR}$		-20	-	80	°C

SM5005A series

Electrical Characteristics

$V_{DD} = 2.7$  to  $3.6V$ ,  $V_{SS} = 0V$ ,  $T_a = -20$  to  $80^{\circ}C$  unless otherwise noted.

Parameter	Symbol	Condition		Rating			Unit	
				min	typ	max		
HIGH-level output voltage	$V_{OH}$	Q: Measurement cct 1, $V_{DD} = 2.7V$ , $I_{OH} = 8mA$		2.2	2.4	–	V	
LOW-level output voltage	$V_{OL}$	Q: Measurement cct 2, $V_{DD} = 2.7V$ , $I_{OL} = 8mA$		–	0.3	0.4	V	
Output leakage current	$I_Z$	Q: Measurement cct 2, INHN = LOW, $V_{DD} = 3.6V$	$V_{OH} = V_{DD}$	–	–	10	$\mu A$	
			$V_{OL} = V_{SS}$	–	–	10		
HIGH-level input voltage	$V_{IH}$	INHN		$0.7V_{DD}$	–	–	V	
LOW-level input voltage	$V_{IL}$	INHN		–	–	$0.3V_{DD}$	V	
Current consumption	$I_{DD}$	INHN = open, Measurement cct 3, load cct 1, $V_{DD} = 3.0V$ to $3.6V$ $f = 125MHz$	$C_L = 30pF$	CF5005AL $\times$	–	40	100	mA
			$C_L = 15pF$	SM5005AL $\times$ V CF5005AL $\times$	–	25	60	
Standby current	$I_{ST}$	INHN = LOW, Measurement cct 3		–	–	10	$\mu A$	
INHN pull-up resistance	$R_{UP1}$	Measurement cct 4, INHN = LOW		0.4	–	4	$M\Omega$	
	$R_{UP2}$	Measurement cct 4, INHN = $0.7V_{DD}$		50	–	150	$k\Omega$	
AC feedback resistance	$R_{f1}$	Design value. A monitor pattern on a wafer is tested.	SM5005ALAV CF5005ALA	1.76	2.2	2.64	$k\Omega$	
			SM5005ALBV CF5005ALB	2.64	3.3	3.96		
			SM5005ALCV CF5005ALC	2.64	3.3	3.96		
			CF5005ALD	2.80	3.5	4.20		
			CF5005ALE	4.48	5.6	6.72		
DC feedback resistance	$R_{f2}$	Measurement cct 5		50	–	150	$k\Omega$	
AC feedback capacitance	$C_f$	Design value. A monitor pattern on a wafer is tested.		9.3	10	10.7	pF	
Built-in capacitance	$C_G$	Design value. A monitor pattern on a wafer is tested.	SM5005ALAV CF5005ALA CF5005ALD CF5005ALE	7.44	8	8.56	pF	
			SM5005ALBV CF5005ALB	5.58	6	6.42		
			SM5005ALCV CF5005ALC	2.79	3	3.21		
	$C_D$	Design value. A monitor pattern on a wafer is tested.	SM5005ALAV CF5005ALA CF5005ALD	9.3	10	10.7	pF	
			SM5005ALBV CF5005ALB	5.58	6	6.42		
			SM5005ALCV CF5005ALC	2.79	3	3.21		
			CF5005ALE	13.95	15	16.05		

## Switching Characteristics

### 3V operation

$V_{SS} = 0V$ ,  $T_a = -20$  to  $80^\circ C$  unless otherwise noted.

Parameter	Symbol	Condition	Rating			Unit		
			min	typ	max			
Output rise time	$t_{r1}$	Measurement cct 3, load cct 1, $0.1V_{DD}$ to $0.9V_{DD}$	$C_L = 15pF$ , $V_{DD} = 2.7V$ to $3.6V$	SM5005AL×V CF5005AL×	–	1	3	ns
	$t_{r2}$		$C_L = 30pF$ , $V_{DD} = 3.0V$ to $3.6V$	CF5005AL×	–	1.5	4	
Output fall time	$t_{f1}$	Measurement cct 3, load cct 1, $0.9V_{DD}$ to $0.1V_{DD}$	$C_L = 15pF$ , $V_{DD} = 2.7V$ to $3.6V$	SM5005AL×V CF5005AL×	–	1	3	ns
	$t_{f2}$		$C_L = 30pF$ , $V_{DD} = 3.0V$ to $3.6V$	CF5005AL×	–	1.5	4	
Output duty cycle <sup>1</sup>	Duty	Measurement cct 3, load cct 1, $T_a = 25^\circ C$ , $V_{DD} = 3.0V$	$C_L = 30pF$ , $f \leq 125MHz$	CF5005AL×	45	–	55	%
			$C_L = 15pF$ , $f \leq 107MHz$	SM5005AL×V	45	–	55	
			$C_L = 15pF$ , $107MHz < f < 125MHz$		40	–	60	
Output disable delay time <sup>2</sup>	$t_{PLZ}$	Measurement cct 6, $T_a = 25^\circ C$ , $V_{DD} = 2.7V$ , $C_L \leq 15pF$			–	–	100	ns
Output enable delay time <sup>2</sup>	$t_{PZL}$	Measurement cct 6, $T_a = 25^\circ C$ , $V_{DD} = 2.7V$ , $C_L \leq 15pF$			–	–	100	ns

1. The duty cycle characteristic is checked the sample chips of each production lot.
2. Oscillator stop function is built-in. When INHN goes LOW, normal output stops. When INHN goes HIGH, normal output is not resumed until after the oscillator start-up time has elapsed.

### 2.5V operation (CF5005ALA, CF5005ALD, CF5005ALE)

$V_{SS} = 0V$ ,  $T_a = -20$  to  $80^\circ C$  unless otherwise noted.

Parameter	Symbol	Condition	Rating			Unit		
			min	typ	max			
Output rise time	$t_{r3}$	Measurement cct 3, load cct 1, $0.1V_{DD}$ to $0.9V_{DD}$ , $C_L = 30pF$ , $V_{DD} = 2.25V$ to $2.75V$	–	2	6	ns		
Output fall time	$t_{f3}$	Measurement cct 3, load cct 1, $0.9V_{DD}$ to $0.1V_{DD}$ , $C_L = 30pF$ , $V_{DD} = 2.25V$ to $2.75V$	–	2	6	ns		
Output duty cycle <sup>1</sup>	Duty	Measurement cct 3, load cct 1, $T_a = 25^\circ C$ , $V_{DD} = 2.5V$ , $C_L = 30pF$ , $f \leq 70MHz$	40	–	60	%		
Output disable delay time <sup>2</sup>	$t_{PLZ}$	Measurement cct 6, $T_a = 25^\circ C$ , $V_{DD} = 2.25V$ , $C_L \leq 15pF$			–	–	300	ns
Output enable delay time <sup>2</sup>	$t_{PZL}$	Measurement cct 6, $T_a = 25^\circ C$ , $V_{DD} = 2.25V$ , $C_L \leq 15pF$			–	–	300	ns

1. The duty cycle characteristic is checked the sample chips of each production lot.
2. Oscillator stop function is built-in. When INHN goes LOW, normal output stops. When INHN goes HIGH, normal output is not resumed until after the oscillator start-up time has elapsed.

---

## FUNCTIONAL DESCRIPTION

### Standby Function

The oscillator stops when INHN goes LOW. When the oscillator stops, the oscillator output on Q goes high impedance.

INHN	Q	Oscillator
HIGH (or open)	$f_O$ output frequency	Normal operation
LOW	High impedance	Stopped

### Power-saving Pull-up Resistor

The INHN pull-up resistance changes in response to the input level (HIGH or LOW). When INHN goes LOW (standby state), the pull-up resistance becomes large to reduce the current consumption during standby.

**MEASUREMENT CIRCUITS**

**Measurement cct 1**

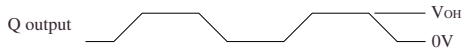
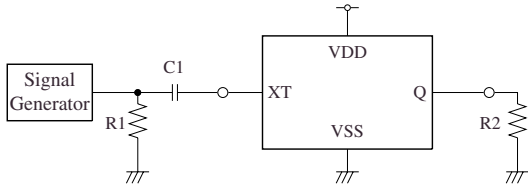

2.5V<sub>p-p</sub>, 10MHz sine wave input signal  
 C1 : 0.001μF  
 R1 : 50Ω  
 R2 : 275Ω

**Measurement cct 4**

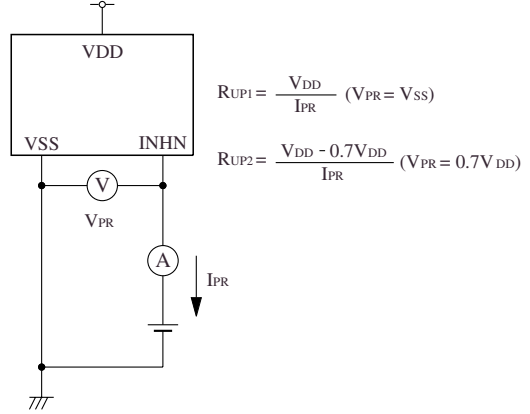

$$R_{UP1} = \frac{V_{DD}}{I_{PR}} \quad (V_{PR} = V_{SS})$$

$$R_{UP2} = \frac{V_{DD} - 0.7V_{DD}}{I_{PR}} \quad (V_{PR} = 0.7V_{DD})$$

**Measurement cct 2**

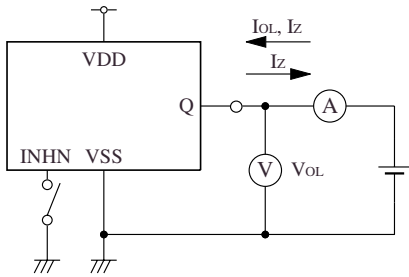

**Measurement cct 5**

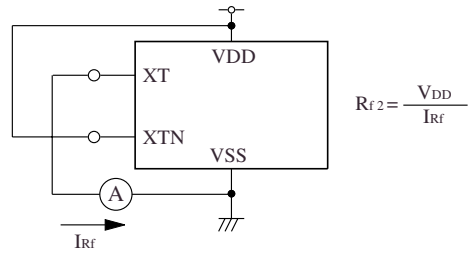

$$R_{f2} = \frac{V_{DD}}{I_{Rf}}$$

**Measurement cct 3**

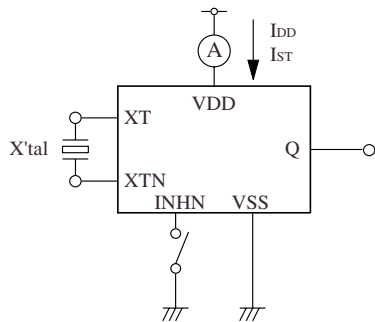

**Measurement cct 6**

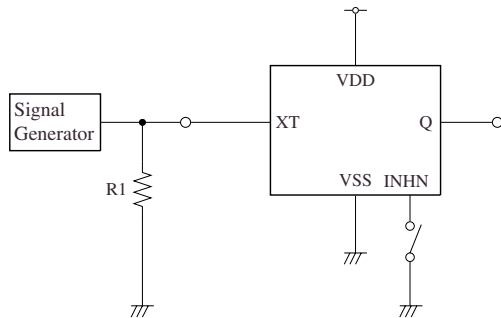

R1 : 50Ω



Please pay your attention to the following points at time of using the products shown in this document.

The products shown in this document (hereinafter "Products") are not intended to be used for the apparatus that exerts harmful influence on human lives due to the defects, failure or malfunction of the Products. Customers are requested to obtain prior written agreement for such use from SEIKO NPC CORPORATION (hereinafter "NPC"). Customers shall be solely responsible for, and indemnify and hold NPC free and harmless from, any and all claims, damages, losses, expenses or lawsuits, due to such use without such agreement. NPC reserves the right to change the specifications of the Products in order to improve the characteristic or reliability thereof. NPC makes no claim or warranty that the contents described in this document dose not infringe any intellectual property right or other similar right owned by third parties. Therefore, NPC shall not be responsible for such problems, even if the use is in accordance with the descriptions provided in this document. Any descriptions including applications, circuits, and the parameters of the Products in this document are for reference to use the Products, and shall not be guaranteed free from defect, inapplicability to the design for the mass-production products without further testing or modification. Customers are requested not to export or re-export, directly or indirectly, the Products to any country or any entity not in compliance with or in violation of the national export administration laws, treaties, orders and regulations. Customers are requested appropriately take steps to obtain required permissions or approvals from appropriate government agencies.

The logo for NPC (Seiko NPC Corporation) consists of the letters 'NPC' in a bold, black, sans-serif font. The 'N' and 'P' are connected at the top, and the 'C' is positioned to the right of the 'P'.

**SEIKO NPC CORPORATION**

15-6, Nihombashi-kabutocho, Chuo-ku,  
Tokyo 103-0026, Japan  
Telephone: +81-3-6667-6601  
Facsimile: +81-3-6667-6611  
<http://www.npc.co.jp/>  
Email: [sales@npc.co.jp](mailto:sales@npc.co.jp)

NC9805GE 2006.04