

### OVERVIEW

The CF5072 series are 155MHz VCXO ICs. They incorporate a 155.52MHz fundamental frequency oscillator circuit and a differential LVPECL output circuit on a single chip. The oscillator circuit features characteristics optimized for VCXO operation, and includes a varicap connection pin. The CF5072 series can be configured with few external components, making them ideal as miniature VCXO modules.

### FEATURES

- 3.0 to 3.6V operating supply voltage range
- 80MHz to 200MHz oscillator frequency range
- Differential LVPECL output
- $50 \pm 5\%$  output duty (measured at the output crossing point)
- Output enable function  
High impedance output when OE = LOW (oscillator continues running)
- $-40$  to  $85^\circ\text{C}$  operating temperature range
- Chip form (CF5072xx)

### BLOCK DIAGRAM

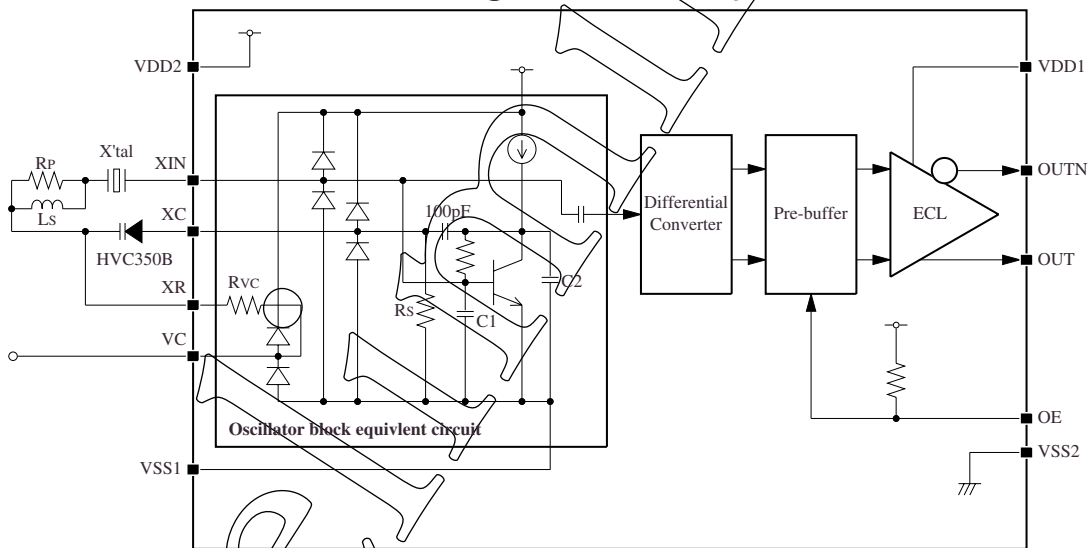

#### ESD sensitive device:

The XR pin is not equipped with a protection circuit. Accordingly, its electrostatic withstand voltage is significantly lower than that of the other pins.

ESD breakdown prevention handling precautions are strongly recommended.

### ORDERING INFORMATION

Device	Package
CF5072xx-1	Chip form

## FUNCTIONAL DESCRIPTION

### Oscillator Equivalent Circuit

The oscillator can be represented by the equivalent circuit shown below. The crystal unit is connected to XIN, and the other terminal is connected to the  $L_S$  and  $R_P$  network. A varicap is added with cathode connected to XR, and anode connected to XC.

The control voltage is applied to the VC pin, with high-resistance element connected between VC and XR built-in.

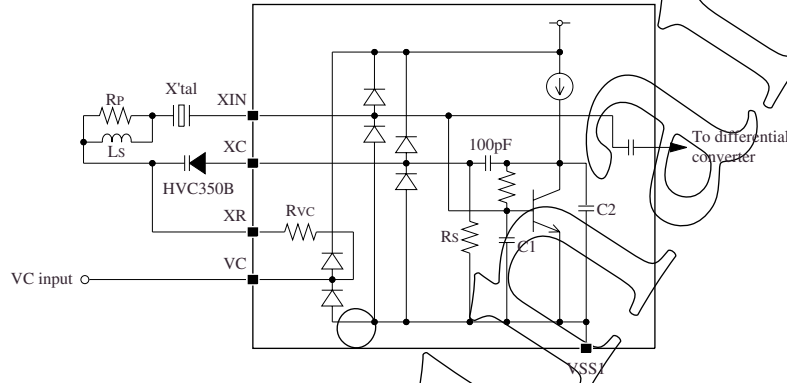

### Oscillator internal capacitors

Version	Internal capacitance [pF] (design value)	
	C1	C2
CF5072AA	11.2	14.4

### Recommended external constants

Oscillator frequency	$L_S$ [nH]	$R_P$ [k $\Omega$ ] <sup>1</sup>
155.52MHz	220	2.2
	180	1.8

- $R_P$  is a damping resistor to prevent parasitic oscillation due the combined effects of the external inductor (expander coil) and varicap capacitance/internal capacitance. It is recommended that  $R_P$  be connected in parallel with  $L_S$ .

### Output Circuit

The output is enabled/disabled using the OE pin. Outputs are high impedance when disabled. The OE pin logic is shown in the following table.

OE	OUT	OUTN
HIGH or open	CLK output	CLK output
LOW	High impedance	High impedance

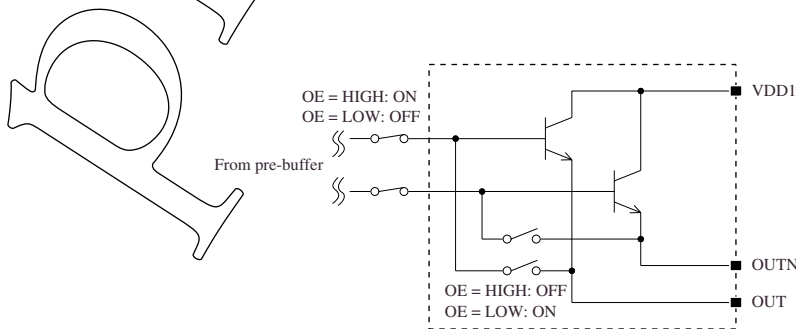

## PAD LAYOUT

(Unit:  $\mu\text{m}$ )

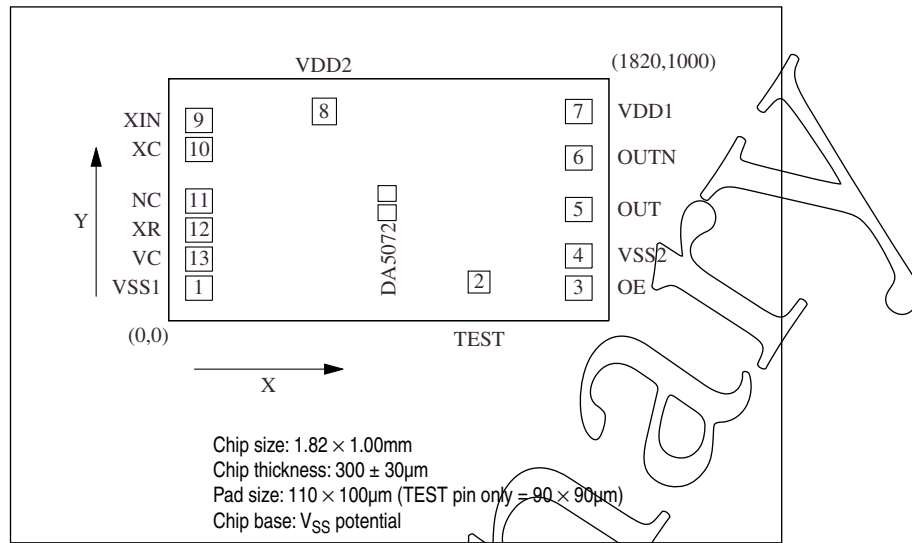

## PAD DESCRIPTION AND DIMENSIONS

Pad No.	Name	I/O	Function	Pad dimensions [ $\mu\text{m}$ ]		Pad size [ $\mu\text{m}$ ]	
				X	Y	X	Y
1	VSS1	-	Oscillator ground	125	135	110	100
2	TEST	I	IC test pin (leave open circuit for normal operation)	1283	160	90	90
3	OE	I	Output enable, with pull-up resistor built-in	1695	135	110	100
4	VSS2	-	Ground	1695	268	110	100
5	OUT	O	Differential PECL non-inverting output (true)	1695	460	110	100
6	OUTN	O	Differential PECL inverting output (complementary)	1695	673	110	100
7	VDD1	-	EGL buffer supply	1695	865	110	100
8	VDD2	-	Supply	643	865	100	110
9	XIN	I	Crystal unit connection	125	828	110	100
10	XC	I	Varicap anode connection	125	708	110	100
11	NC	-	No connection	125	495	110	100
12	XR <sup>1</sup>	I	Varicap cathode connection and inductor connection	125	375	110	100
13	VC	I	Control voltage pin	125	255	110	100

1. The XR pin electrostatic withstand voltage is weaker than the other pins. The electrostatic withstand voltage of pins, excluding XR, is the same as that for existing NPC devices.

**ABSOLUTE MAXIMUM RATINGS**

Parameter	Symbol	Conditions	Rating	Unit
Supply voltage range	$V_{DD}$		$V_{SS} - 0.5$ to $V_{SS} + 7.0$	V
Input voltage range	$V_{IN}$		$V_{SS} - 0.5$ to $V_{DD} + 0.5$	V
Storage temperature range	$T_{STG}$		-65 to 150	°C

**RECOMMENDED OPERATING CONDITIONS**

Parameter	Symbol	Conditions	Rating			Unit
			Min	Typ	Max	
Supply voltage	$V_{DD}$		3.0		3.6	V
Operating temperature	$T_{OPR}$		-40		85	°C
Output load	$R_L$	Terminated to $V_{DD} - 2V$	-	50	-	$\Omega$
Output frequency	$f_{OUT}$		80	-	200	MHz

**ELECTRICAL CHARACTERISTICS****DC Characteristics**

Recommended operating conditions apply unless otherwise noted

Parameter	Symbol	Conditions	Rating			Unit
			Min	Typ	Max	
Current consumption	$I_{DD}$	Measurement circuit 1, output terminated to $V_{DD} - 2V$ , OE = OPEN	-	50	88	mA
OUT/OUTN HIGH-level output voltage	$V_{OH}$	Measurement circuit 2, $T_a = 0$ to $85^\circ\text{C}$	2.275	2.350	2.420	V
		$T_a = -40^\circ\text{C}$	2.215	2.295	2.420	V
OUT/OUTN LOW-level output voltage	$V_{OL}$	Measurement circuit 2, $V_{DD} = 3.3V$ , OE = OPEN, $T_a = 0$ to $85^\circ\text{C}$	1.490	1.600	1.680	V
		$T_a = -40^\circ\text{C}$	1.470	1.605	1.745	V
OE HIGH-level input voltage	$V_{IH}$	Measurement circuit 3	$0.7V_{CC}$	-	-	V
OE LOW-level input voltage	$V_{IL}$	Measurement circuit 3	-	-	$0.3V_{CC}$	V
OE LOW-level input current	$I_{IL}$	Measurement circuit 4, $V_{IL} = 0V$	-	-	-20	$\mu\text{A}$
Input impedance	$Z_{IN}$	Measurement circuit 5, measured between supply and VC	10	-	-	M $\Omega$
VC resistance	$R_{VC}$	Measurement circuit 6, measured between VC and XR	100	150	200	k $\Omega$
Pull-down resistance	$R_S$	Measurement circuit 7, measured between VSS and XC	10	20	40	k $\Omega$

**AC Characteristics**

Recommended operating conditions apply unless otherwise noted

Parameter	Symbol	Conditions	Rating			Unit
			Min	Typ	Max	
Output duty cycle 1	Duty1	Measurement circuit 1, measured at output crossing point, Ta = 25°C, V <sub>DD</sub> = 3.3V	45	50	55	%
Output duty cycle 2	Duty2	Measurement circuit 1, measured at 50% output swing, Ta = 25°C, V <sub>DD</sub> = 3.3V	45	50	55	%
Output swing <sup>1</sup>	V <sub>Opp</sub>	Measurement circuit 1, peak-to-peak of output waveform	0.4	-	-	V
Output rise time	t <sub>r</sub>	Measurement circuit 1, output swing 20% to 80%	-	0.5	1	ns
Output fall time	t <sub>f</sub>	Measurement circuit 1, output swing 80% to 20%	-	0.5	1	ns
Output enable delay time	t <sub>OE</sub>	Measurement circuit 3, Ta = 25°C	-	-	200	ns
Output disable delay time	t <sub>OD</sub>	Measurement circuit 3, Ta = 25°C	-	-	200	ns

1. The said values are measured by using the NPC standard jig.

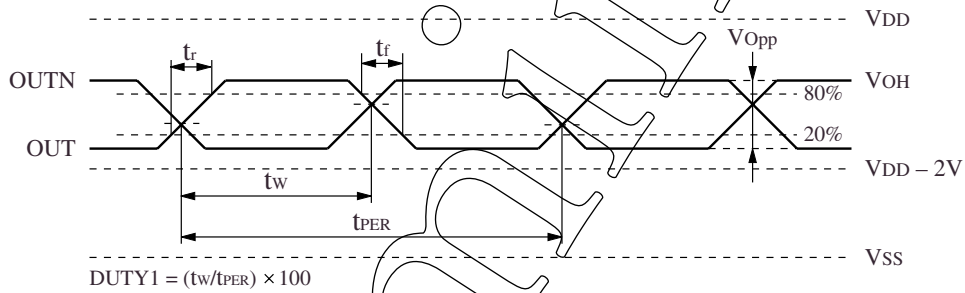

Figure 1. PECL output waveform

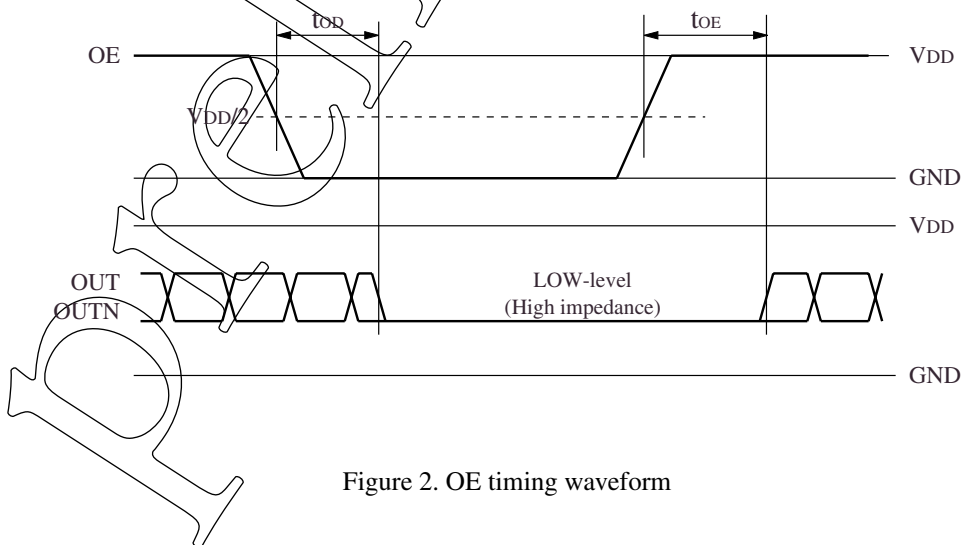
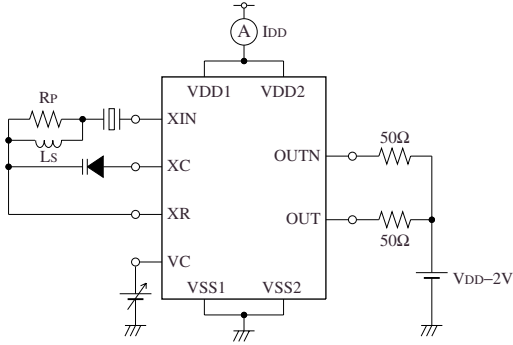

Figure 2. OE timing waveform

## MEASUREMENT CIRCUITS

### Measurement Circuit 1

Parameters:  $I_{DD}$ , Duty1, Duty2,  $V_{Opp}$ ,  $t_p$ ,  $t_f$



### Measurement Circuit 4

Parameter:  $I_{IL}$

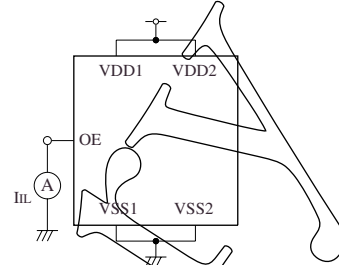

### Measurement Circuit 2

Parameters:  $V_{OH}$ ,  $V_{OL}$

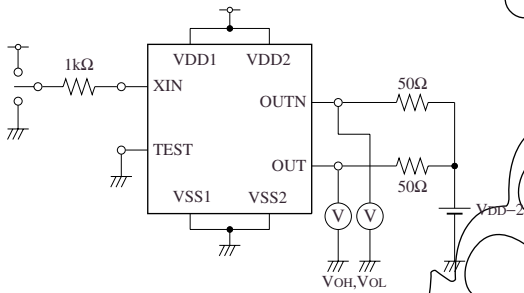

When XIN = HIGH: OUT is tied LOW ( $V_{OL}$ )  
 OUTN is tied HIGH ( $V_{OH}$ )  
 When XOUT = LOW: OUT is tied HIGH ( $V_{OH}$ )  
 OUTN is tied LOW ( $V_{OL}$ )

### Measurement Circuit 3

Parameters:  $V_{IH}$ ,  $V_{IL}$ ,  $t_{OE}$ ,  $t_{OD}$

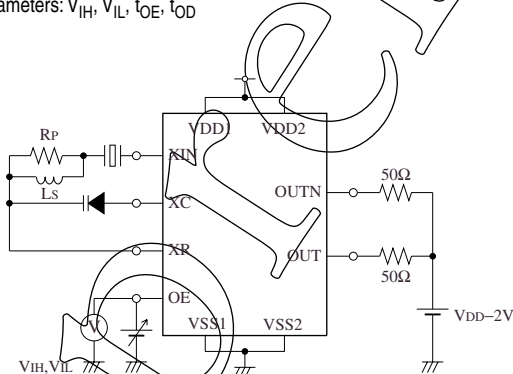

$V_{IH}$ : output state changes  $V_{SS} \rightarrow V_{DD}$   
 $V_{IL}$ : output state changes  $V_{DD} \rightarrow V_{SS}$   
 OE: disable function

### Measurement Circuit 5

Parameter:  $Z_{IN}$

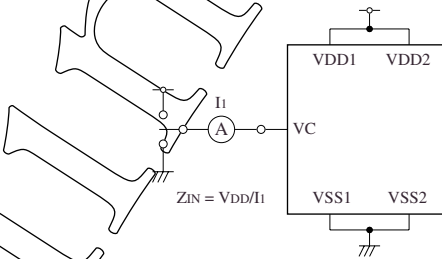

### Measurement Circuit 6

Parameter:  $R_{VC}$

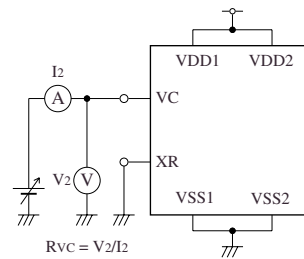

### Measurement Circuit 7

Parameter:  $R_S$

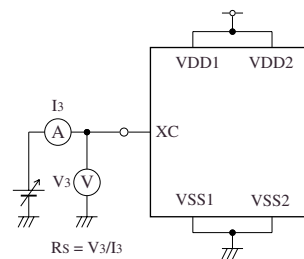

Preliminary

Please pay your attention to the following points at time of using the products shown in this document.

The products shown in this document (hereinafter "Products") are not intended to be used for the apparatus that exerts harmful influence on human lives due to the defects, failure or malfunction of the Products. Customers are requested to obtain prior written agreement for such use from NIPPON PRECISION CIRCUITS INC. (hereinafter "NPC"). Customers shall be solely responsible for, and indemnify and hold NPC free and harmless from, any and all claims, damages, losses, expenses or lawsuits, due to such use without such agreement. NPC reserves the right to change the specifications of the Products in order to improve the characteristic or reliability thereof. NPC makes no claim or warranty that the contents described in this document dose not infringe any intellectual property right or other similar right owned by third parties. Therefore, NPC shall not be responsible for such problems, even if the use is in accordance with the descriptions provided in this document. Any descriptions including applications, circuits, and the parameters of the Products in this document are for reference to use the Products, and shall not be guaranteed free from defect, inapplicability to the design for the mass-production products without further testing or modification. Customers are requested not to export or re-export, directly or indirectly, the Products to any country or any entity not in compliance with or in violation of the national export administration laws, treaties, orders and regulations. Customers are requested appropriately take steps to obtain required permissions or approvals from appropriate government agencies.

**NPC**  
NIPPON PRECISION CIRCUITS INC.

NIPPON PRECISION CIRCUITS INC.

4-3, Fukuzumi 2-chome, Koto-ku,  
Tokyo 135-8430, Japan  
Telephone: +81-3-3642-6661  
Facsimile: +81-3-3642-6698  
<http://www.npc.co.jp/>  
Email: [sales@npc.co.jp](mailto:sales@npc.co.jp)

NP0212AE 2003.03