

OVERVIEW

The CF5035 series are 1.8V operation, high-frequency crystal oscillator module ICs. They support 70MHz to 165MHz (1.8V) and 70MHz to 220MHz (2.5 to 3.3V) 3rd overtone oscillation and fundamental oscillation modes. The crystal oscillator circuit is a Colpitts oscillator with the necessary oscillator capacitors and feedback resistor built-in. The oscillation characteristics feature little variation with supply voltage, providing stable oscillation over a wide supply voltage range. The output circuit comprises a CMOS buffer that can operate at high frequencies and drive a 15pF capacitance load. The devices are fabricated using a proprietary BiCMOS process with the oscillator circuit and output buffer on a single chip, making them ideal as SMD-type high-frequency crystal oscillators.

FEATURES

- 1.6 to 3.6V operating supply voltage range
- Oscillation frequency range (varies with version)
 - 1.6 to 3.6V: 70MHz to 165MHz
 - 2.25 to 3.6V: 70MHz to 220MHz
- – 40 to 85°C operating temperature range
- Oscillation capacitors built-in
- Inverter amplifier feedback resistor built-in
- Oscillation detector function built-in
- Standby function
 - High impedance in standby mode, oscillator stops
- Low standby current
 - Power-saving pull-up resistor built-in
- CMOS output duty level
- 15pF output load
- 8mA output drive capability ($V_{DD} = 1.6V$)
- BiCMOS process
- Chip form (CF5035AL×)

APPLICATIONS

- 1.8V, high-frequency crystal oscillator modules

SERIES CONFIGURATION

Version	Operating supply voltage range [V]	Recommended operating frequency range ¹ [MHz]	Built-in capacitance [pF]	
			C _{IN}	C _{OUT}
CF5035ALA	1.6 to 3.6	70 to 95	4	4
CF5035ALB		95 to 125	4	4
CF5035ALC		125 to 165	2	2
CF5035ALD	2.25 to 3.6	165 to 220	1	1

1. The recommended operating frequency is a yardstick value derived from the crystal used for NPC characteristics authentication. However, the oscillator frequency band is not guaranteed. Specifically, the characteristics can vary greatly due to crystal characteristics and mounting conditions, so the oscillation characteristics of components must be carefully evaluated.

ORDERING INFORMATION

Device	Package
CF5035AL×-1	Chip form

PAD LAYOUT

(Unit: μm)

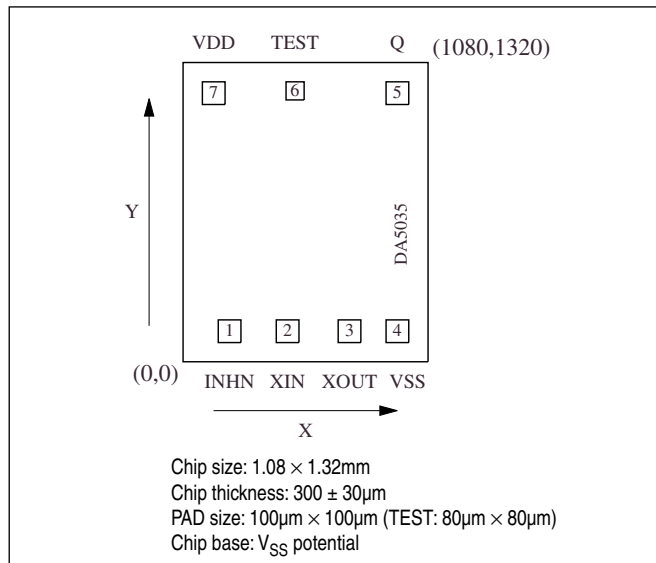

PIN DESCRIPTION and PAD DIMENSIONS

No.	Name	I/O	Description	Pad dimensions [μm]	
				X	Y
1	INHN	I	Output state control input. Oscillator stops when LOW. Power-saving pull-up resistor built-in.	205	135
2	XIN	I	Oscillator input	461	135
3	XOUT	O	Oscillator output	734	135
			Crystal connection pins. Crystal is connected between XIN and XOUT.		
4	VSS	-	(-) ground	945	135
5	Q	O	Output. Output frequency. High impedance in standby mode	945	1185
6	TEST	I	Test (leave open)	494	1195
7	VDD	-	(+) supply voltage	135	1185

BLOCK DIAGRAM

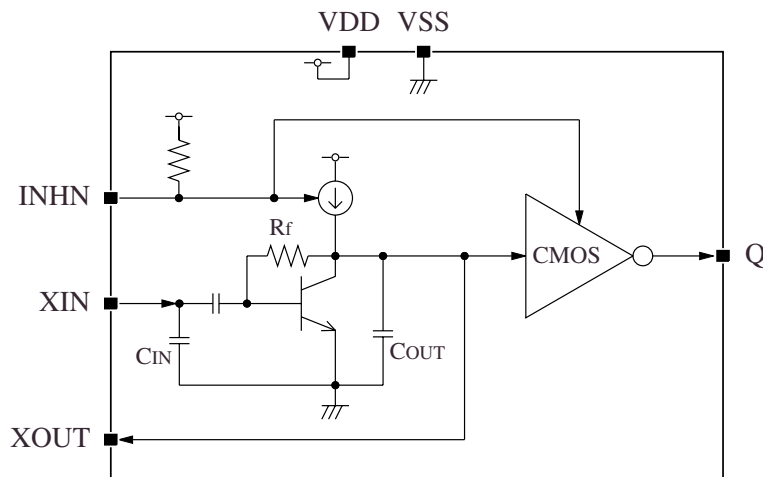

ABSOLUTE MAXIMUM RATINGS

Parameter	Symbol	Condition	Rating	Unit
Supply voltage range	V_{DD}	Between VDD and VSS	-0.5 to +5.0	V
Input voltage range	V_{IN}	Input pins	$V_{SS} - 0.5$ to $V_{DD} + 0.5$	V
Output voltage range	V_{OUT}	Output pins	$V_{SS} - 0.5$ to $V_{DD} + 0.5$	V
Output current	I_{OUT}	Q pin	25	mA
Storage temperature range	T_{STG}	Chip form	-65 to +150	°C

RECOMMENDED OPERATING CONDITIONS $C_L \leq 15\text{pF}$

Parameter	Symbol	Condition		Rating			Unit
				min	typ	max	
Supply voltage	V_{DD}	$70\text{MHz} \leq f \leq 95\text{MHz}$	5035ALA	1.6	-	3.6	V
		$95\text{MHz} \leq f \leq 125\text{MHz}$	5035ALB	1.6	-	3.6	V
		$125\text{MHz} \leq f \leq 165\text{MHz}$	5035ALC	1.6	-	3.6	V
		$165\text{MHz} \leq f \leq 220\text{MHz}$	5035ALD	2.25	-	3.6	V
Input voltage	V_{IN}	Input pins		V_{SS}	-	V_{DD}	V
Operating temperature	T_{OPR}	Chip temperature		-40	+25	+85	°C

ELECTRICAL CHARACTERISTICS

DC Characteristics

Recommended operating conditions unless otherwise noted.

Parameter	Symbol	Condition	Rating			Unit		
			min	typ	max			
Operating current consumption ¹	I_{DD}	Measurement cct 1, INHN = open or HIGH, $C_L = 15\text{pF}$	5035ALA $f = 95\text{MHz}$	$V_{DD} = 1.6 \text{ to } 2.0\text{V}$	–	11	19	mA
				$V_{DD} = 2.25 \text{ to } 2.75\text{V}$	–	16	26	mA
				$V_{DD} = 2.75 \text{ to } 3.6\text{V}$	–	20	33	mA
			5035ALB $f = 125\text{MHz}$	$V_{DD} = 1.6 \text{ to } 2.0\text{V}$	–	17	27	mA
				$V_{DD} = 2.25 \text{ to } 2.75\text{V}$	–	23	36	mA
				$V_{DD} = 2.75 \text{ to } 3.6\text{V}$	–	29	46	mA
			5035ALC $f = 165\text{MHz}$	$V_{DD} = 1.6 \text{ to } 2.0\text{V}$	–	23	37	mA
				$V_{DD} = 2.25 \text{ to } 2.75\text{V}$	–	31	51	mA
				$V_{DD} = 2.75 \text{ to } 3.6\text{V}$	–	39	65	mA
			5035ALD $f = 220\text{MHz}$	$V_{DD} = 2.25 \text{ to } 2.75\text{V}$	–	38	58	mA
				$V_{DD} = 2.75 \text{ to } 3.6\text{V}$	–	48	73	mA
			Standby current	I_{ST}	Measurement cct 1, INHN = LOW	–	–	10
HIGH-level output voltage	V_{OH}	Q: Measurement cct 3, $V_{DD} = 1.6 \text{ to } 3.6\text{V}$, $I_{OH} = 8\text{mA}$	$V_{DD} - 0.4$	$V_{DD} - 0.3$	–	V		
LOW-level output voltage	V_{OL}	Q: Measurement cct 3, $V_{DD} = 1.6 \text{ to } 3.6\text{V}$, $I_{OL} = 8\text{mA}$	–	0.3	0.4	V		
Output leakage current	I_Z	Q: Measurement cct 5, INHN = LOW, $V_{DD} = 3.6\text{V}$	$V_{OH} = V_{DD}$	–	–	10	μA	
			$V_{OL} = V_{SS}$	–	–	10	μA	
HIGH-level input voltage	V_{IH}	INHN, Measurement cct 4	$0.7V_{DD}$	–	–	V		
LOW-level input voltage	V_{IL}	INHN, Measurement cct 4	–	–	$0.3V_{DD}$	V		
INHN pull-up resistance	R_{PU1}	Measurement cct 6	INHN = V_{SS}	0.4	–	4	$\text{M}\Omega$	
	R_{PU2}		INHN = $0.7V_{DD}$	30	–	150	$\text{k}\Omega$	

1. The operating current consumption includes the $C_L = 15\text{pF}$ capacitance load charging current.

AC Characteristics

Recommended operating conditions unless otherwise noted.

Parameter	Symbol	Condition	Rating			Unit	
			min	typ	max		
Output duty cycle	Duty	Measurement cct 1, $T_a = 25^\circ\text{C}$, $C_L = 15\text{pF}$	$V_{DD} = 2.25 \text{ to } 3.6\text{V}$	45	50	55	%
			$V_{DD} = 1.6 \text{ to } 2.25\text{V}$	40	50	60	%
Rise time	t_{r1}	Measurement cct 1, $C_L = 15\text{pF}$, $V_{DD} = 2.25 \text{ to } 3.6\text{V}$, $0.1V_{DD}$ to $0.9V_{DD}$	-	1	2	ns	
	t_{r2}	Measurement cct 1, $C_L = 15\text{pF}$, $V_{DD} = 1.6 \text{ to } 2.25\text{V}$, $0.2V_{DD}$ to $0.8V_{DD}$	-	1.5	2.5	ns	
Fall time	t_{f1}	Measurement cct 1, $C_L = 15\text{pF}$, $V_{DD} = 2.25 \text{ to } 3.6\text{V}$, $0.9V_{DD}$ to $0.1V_{DD}$	-	1	2	ns	
	t_{f2}	Measurement cct 1, $C_L = 15\text{pF}$, $V_{DD} = 1.6 \text{ to } 2.25\text{V}$, $0.8V_{DD}$ to $0.2V_{DD}$	-	1.5	2.5	ns	
Output enable delay time ¹	t_{OE}	Measurement cct 2, $T_a = 25^\circ\text{C}$, $C_L \leq 15\text{pF}$, INHN = LOW \rightarrow HIGH	-	-	2	ms	
Output disable delay time	t_{OD}	Measurement cct 2, $T_a = 25^\circ\text{C}$, $C_L \leq 15\text{pF}$, INHN = HIGH \rightarrow LOW	-	-	200	ns	

1. Oscillator stop function is built-in. When INHN goes LOW, normal output stops. When INHN goes HIGH, normal output is not resumed until after the oscillator start-up time has elapsed.

Timing chart

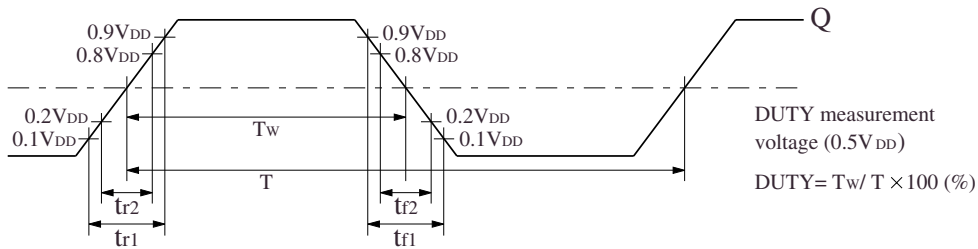

Figure 1. Output switching waveform

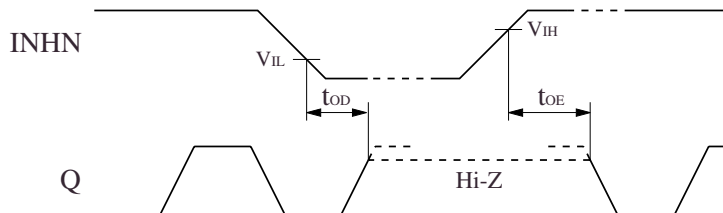

Figure 2. Output disable/enable timing chart

FUNCTIONAL DESCRIPTION

Standby Function

When INHN goes LOW, the device is in standby mode. The Q output becomes high impedance and the oscillator circuit stops.

INHN	Q	Oscillator
HIGH (or open)	f_O output frequency	Normal operation
LOW	High impedance	Stopped

Power-saving Pull-up Resistor

The INHN pin pull-up resistance changes in response to the input level (HIGH or LOW). When INHN is tied LOW, the pull-up resistance becomes large, reducing the current consumed by the resistance. When INHN is left open, the pull-up resistance becomes small, such that even if the input is affected by external noise the outputs are stable due to INHN being tied HIGH by the pull-up resistor.

Oscillation Detector Function

The devices also feature an oscillation detector circuit. This circuit functions to disable the outputs until the oscillator circuit starts. This prevents abnormal oscillator output at oscillator start-up when power is applied or when INHN is switched.

MEASUREMENT CIRCUITS

Measurement cct 1

Measurement parameter: I_{DD} , I_{ST} , Duty, t_r , t_f

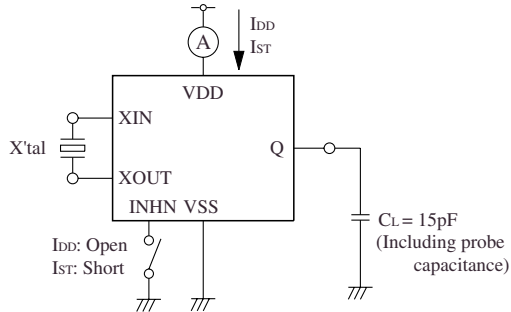

Note: The AC characteristics are observed using an oscilloscope on pin Q.

Measurement cct 4

Measurement parameter: V_{IH} , V_{IL}

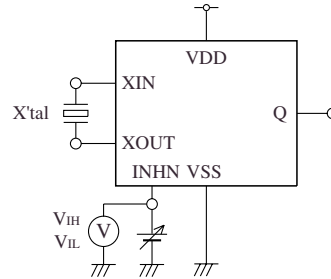

V_{IH} : Voltage in V_{SS} to V_{DD} transition that changes the output state.
 V_{IL} : Voltage in V_{DD} to V_{SS} transition that changes the output state.
 INHN has an oscillation stop function.

Measurement cct 5

Measurement parameter: t_{OE} , t_{OD}

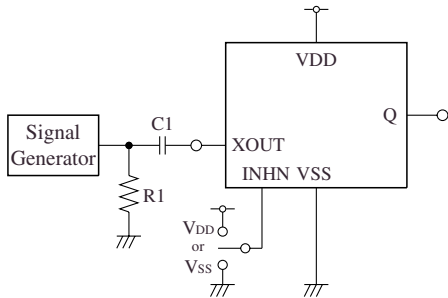

XIN input signal: 1Vp-p, sine wave
 $C1$: 0.001 μ F
 $R1$: 50 Ω

Measurement cct 6

Measurement parameter: I_Z

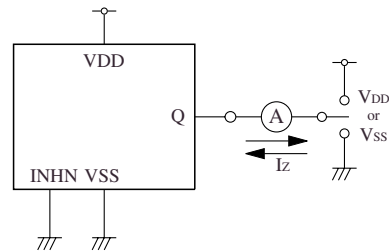

Measurement cct 7

Measurement parameter: R_{PU1} , R_{PU2}

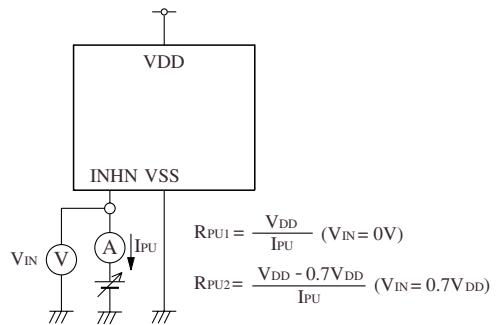

Measurement cct 3

Measurement parameter: V_{OH} , V_{OL}

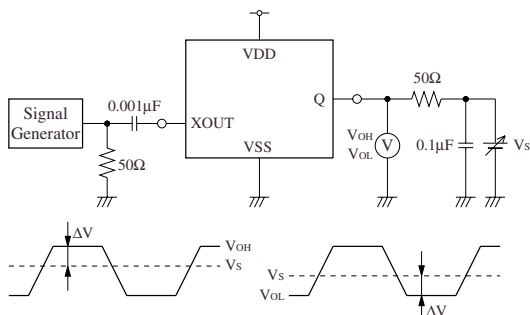

V_S adjusted such that $\Delta V = 50 \times I_{OH}$.
 V_S adjusted such that $\Delta V = 50 \times I_{OL}$.

XOUT input signal: 1Vp-p, sine wave

Please pay your attention to the following points at time of using the products shown in this document.

The products shown in this document (hereinafter "Products") are not intended to be used for the apparatus that exerts harmful influence on human lives due to the defects, failure or malfunction of the Products. Customers are requested to obtain prior written agreement for such use from SEIKO NPC CORPORATION (hereinafter "NPC"). Customers shall be solely responsible for, and indemnify and hold NPC free and harmless from, any and all claims, damages, losses, expenses or lawsuits, due to such use without such agreement. NPC reserves the right to change the specifications of the Products in order to improve the characteristic or reliability thereof. NPC makes no claim or warranty that the contents described in this document dose not infringe any intellectual property right or other similar right owned by third parties. Therefore, NPC shall not be responsible for such problems, even if the use is in accordance with the descriptions provided in this document. Any descriptions including applications, circuits, and the parameters of the Products in this document are for reference to use the Products, and shall not be guaranteed free from defect, inapplicability to the design for the mass-production products without further testing or modification. Customers are requested not to export or re-export, directly or indirectly, the Products to any country or any entity not in compliance with or in violation of the national export administration laws, treaties, orders and regulations. Customers are requested appropriately take steps to obtain required permissions or approvals from appropriate government agencies.

The logo for SEIKO NPC CORPORATION, consisting of the letters 'NPC' in a bold, black, sans-serif font.

SEIKO NPC CORPORATION

15-6, Nihombashi-kabutocho, Chuo-ku,
Tokyo 103-0026, Japan
Telephone: +81-3-6667-6601
Facsimile: +81-3-6667-6611
<http://www.npc.co.jp/>
Email: sales@npc.co.jp

NC0306BE 2006.04