

OVERVIEW

The CF5012 series are low-current consumption 3rd overtone crystal oscillator module ICs. Internal circuit optimization means these devices have reduced current consumption in comparison with our existing 3rd overtone oscillator devices. The crystal oscillator circuit has a built-in thin-film feedback resistor with good temperature characteristics and built-in capacitors with excellent frequency response, resulting in a stable 3rd overtone oscillator with only the connection of a crystal element.

FEATURES

- 3rd overtone oscillation
- 2.7 to 3.6V operating supply voltage range
- 30 to 45MHz recommended operating frequency range
- Inverter amplifier feedback resistor built-in
- Oscillator capacitors C_G , C_D built-in
- Output three-state function (high impedance in standby mode)
- f_O output frequency (oscillator frequency)
- 8mA output drive capability ($V_{DD} = 2.7V$)
- 6.5mA (typ) low current consumption ($V_{DD} = 3V$, $C_L = 15pF$, $f = 40MHz$)
- CMOS output duty level
- Chip form (CF5012xxx)

SERIES CONFIGURATION

Version	Recommended operating frequency range ¹ [MHz]	gm ratio	Built-in capacitance [pF]		R_f [k Ω]
			C_G	C_D	
CF5012ANB	30 to 45	1.0	8	15	3.1

1. The recommended operating frequency is a yardstick value derived from the crystal used for NPC characteristics authentication. However, the oscillator frequency band is not guaranteed. Specifically, the characteristics can vary greatly due to crystal characteristics and mounting conditions, so the oscillation characteristics of components must be carefully evaluated.

ORDERING INFORMATION

Device	Package
CF5012xxx-1	Chip form

PAD LAYOUT

(Unit: μm)

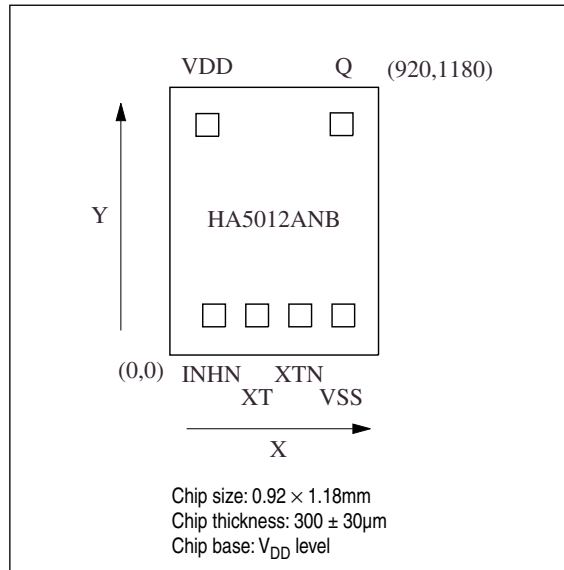

PIN DESCRIPTION and PAD DIMENSIONS

Name	I/O	Description	Pad dimensions [μm]	
			X	Y
INHN	I	Output state control input. High impedance when LOW. Pull-up resistor built in	195	174.4
XT	I	Amplifier input	385	174.4
XTN	O	Amplifier output		
Crystal oscillator connection pins. Crystal oscillator connected between XT and XTN			575	174.4
VSS	-	Ground	765	174.4
Q	O	Output. Output frequency. High impedance in standby mode	757.6	1017.6
VDD	-	Supply voltage	165.4	1014.6

BLOCK DIAGRAM

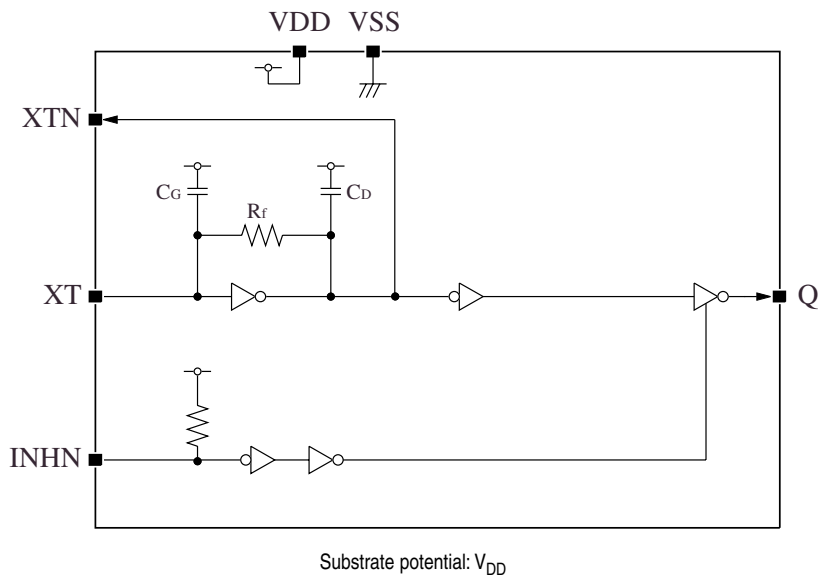

SPECIFICATIONS

Absolute Maximum Ratings

$$V_{SS} = 0V$$

Parameter	Symbol	Condition	Rating	Unit
Supply voltage range	V_{DD}		-0.5 to +7.0	V
Input voltage range	V_{IN}		-0.5 to $V_{DD} + 0.5$	V
Output voltage range	V_{OUT}		-0.5 to $V_{DD} + 0.5$	V
Operating temperature range	T_{opr}		-40 to +85	°C
Storage temperature range	T_{stg}		-65 to +150	°C
Output current	I_{OUT}		25	mA

Recommended Operating Conditions

$$V_{SS} = 0V, f \leq 45\text{MHz}, C_L = 15\text{pF unless otherwise noted.}$$

Parameter	Symbol	Condition	Rating			Unit
			min	typ	max	
Supply voltage	V_{DD}		2.7	-	3.6	V
Input voltage	V_{IN}		V_{SS}	-	V_{DD}	V
Operating temperature	T_{OPR}		-20	-	+80	°C

Electrical Characteristics

$$V_{DD} = 2.7 \text{ to } 3.6V, V_{SS} = 0V, T_a = -20 \text{ to } +80^\circ\text{C unless otherwise noted.}$$

Parameter	Symbol	Condition	Rating			Unit	
			min	typ	max		
HIGH-level output voltage	V_{OH}	Q: Measurement cct 1, $V_{DD} = 2.7V, I_{OH} = 8\text{mA}$	2.2	2.4	-	V	
LOW-level output voltage	V_{OL}	Q: Measurement cct 2, $V_{DD} = 2.7V, I_{OL} = 8\text{mA}$	-	0.3	0.4	V	
Output leakage current	I_Z	Q: Measurement cct 2, INHN = LOW, $V_{DD} = 3.6V$	$V_{OH} = V_{DD}$	-	-	10	μA
			$V_{OL} = V_{SS}$	-	-	10	μA
HIGH-level input voltage	V_{IH}	INHN	$0.7V_{DD}$	-	-	V	
LOW-level input voltage	V_{IL}	INHN	-	-	$0.3V_{DD}$	V	
Current consumption	I_{DD}	Measurement cct 3, load cct 1, INHN = open, $C_L = 15\text{pF}$, $f = 40\text{MHz}$	-	6.5	13	mA	
INHN pull-up resistance	R_{UP}	Measurement cct 4	40	100	250	$\text{k}\Omega$	
Feedback resistance	R_f	Measurement cct 5	2.63	3.1	3.57	$\text{k}\Omega$	
Built-in capacitance	C_G	Design value. A monitor pattern on a wafer is tested.	7	8	9	pF	
	C_D		13	15	17	pF	

Switching Characteristics

$V_{DD} = 2.7$ to $3.6V$, $V_{SS} = 0V$, $T_a = -20$ to $+80^\circ C$ unless otherwise noted.

Parameter	Symbol	Condition	Rating			Unit
			min	typ	max	
Output rise time	t_r	Measurement cct 3, load cct 1, $0.1V_{DD}$ to $0.9V_{DD}$, $C_L = 15pF$	–	2.0	4.0	ns
Output fall time	t_f	Measurement cct 3, load cct 1, $0.9V_{DD}$ to $0.1V_{DD}$, $C_L = 15pF$	–	2.0	4.0	ns
Output duty cycle ¹	Duty	Measurement cct 3, load cct 1, $T_a = 25^\circ C$, $V_{DD} = 3.0V$, $C_L = 15pF$, $f = 40MHz$	40	–	60	%
Output disable delay time	t_{PLZ}	Measurement cct 3, load cct 1, $T_a = 25^\circ C$, $V_{DD} = 3.0V$, $C_L = 15pF$	–	–	100	ns
Output enable delay time	t_{PZL}		–	–	100	ns

1. The duty cycle characteristic is checked the sample chips of each production lot.

Current consumption and Output waveform with NPC's standard crystal

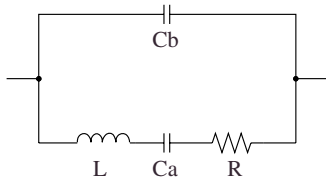

f [MHz]	R [Ω]	L [mH]	Ca [fF]	Cb [pF]
40	20.53	11.34	1.396	3.989

FUNCTIONAL DESCRIPTION

Standby Function

When INHN goes LOW, the oscillator output on Q goes high impedance.

INHN	Q	Oscillator
HIGH (or open)	f_O output frequency	Normal operation
LOW	High impedance	Normal operation

MEASUREMENT CIRCUITS

Measurement cct 1

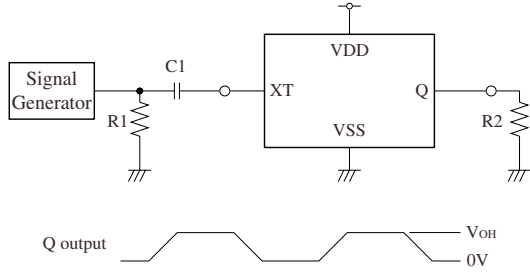

2.0V_{P-P}, 10MHz sine wave input signal
 C1 : 0.001μF
 R1 : 50Ω
 R2 : 275Ω

Measurement cct 4

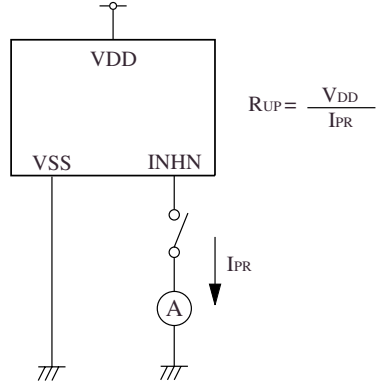

Measurement cct 2

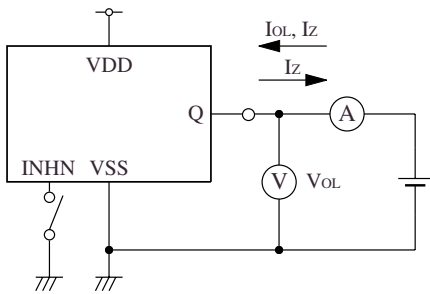

Measurement cct 5

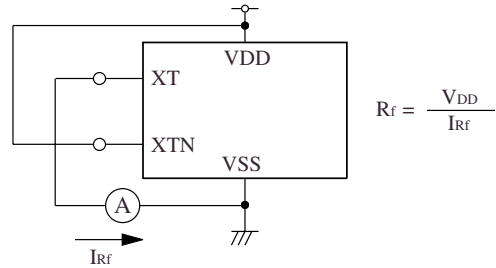

Measurement cct 3

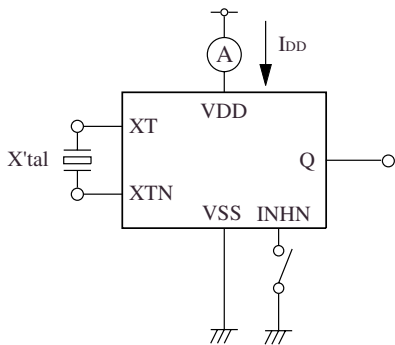

Load cct 1

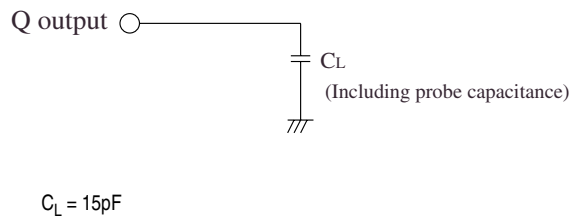

Switching Time Measurement Waveform

t_r , t_f , Duty

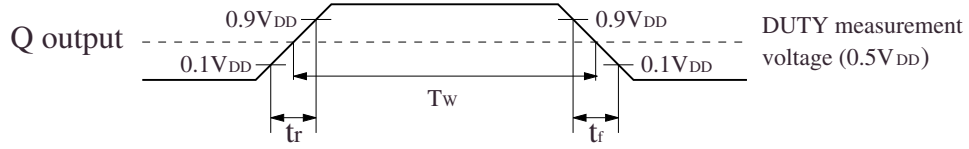

Output duty cycle

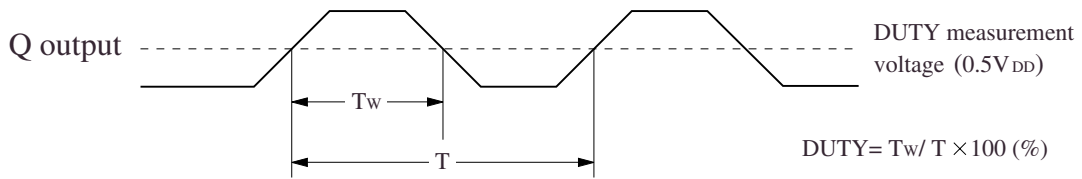

Output Enable/Disable Delay

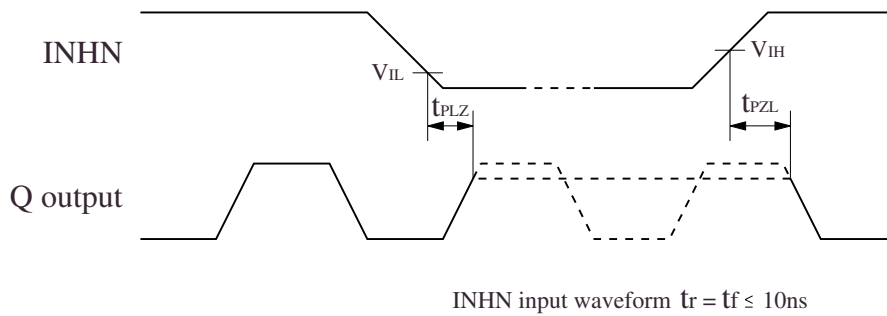

Please pay your attention to the following points at time of using the products shown in this document.

The products shown in this document (hereinafter "Products") are not intended to be used for the apparatus that exerts harmful influence on human lives due to the defects, failure or malfunction of the Products. Customers are requested to obtain prior written agreement for such use from SEIKO NPC CORPORATION (hereinafter "NPC"). Customers shall be solely responsible for, and indemnify and hold NPC free and harmless from, any and all claims, damages, losses, expenses or lawsuits, due to such use without such agreement. NPC reserves the right to change the specifications of the Products in order to improve the characteristic or reliability thereof. NPC makes no claim or warranty that the contents described in this document dose not infringe any intellectual property right or other similar right owned by third parties. Therefore, NPC shall not be responsible for such problems, even if the use is in accordance with the descriptions provided in this document. Any descriptions including applications, circuits, and the parameters of the Products in this document are for reference to use the Products, and shall not be guaranteed free from defect, inapplicability to the design for the mass-production products without further testing or modification. Customers are requested not to export or re-export, directly or indirectly, the Products to any country or any entity not in compliance with or in violation of the national export administration laws, treaties, orders and regulations. Customers are requested appropriately take steps to obtain required permissions or approvals from appropriate government agencies.

The logo for SEIKO NPC CORPORATION, consisting of the letters 'NPC' in a bold, black, sans-serif font.

SEIKO NPC CORPORATION

15-6, Nihombashi-kabutocho, Chuo-ku,
Tokyo 103-0026, Japan
Telephone: +81-3-6667-6601
Facsimile: +81-3-6667-6611
<http://www.npc.co.jp/>
Email: sales@npc.co.jp

NC0111BE 2006.04