

## Block Diagram

### Memory Audio Built-in Radio Tuner

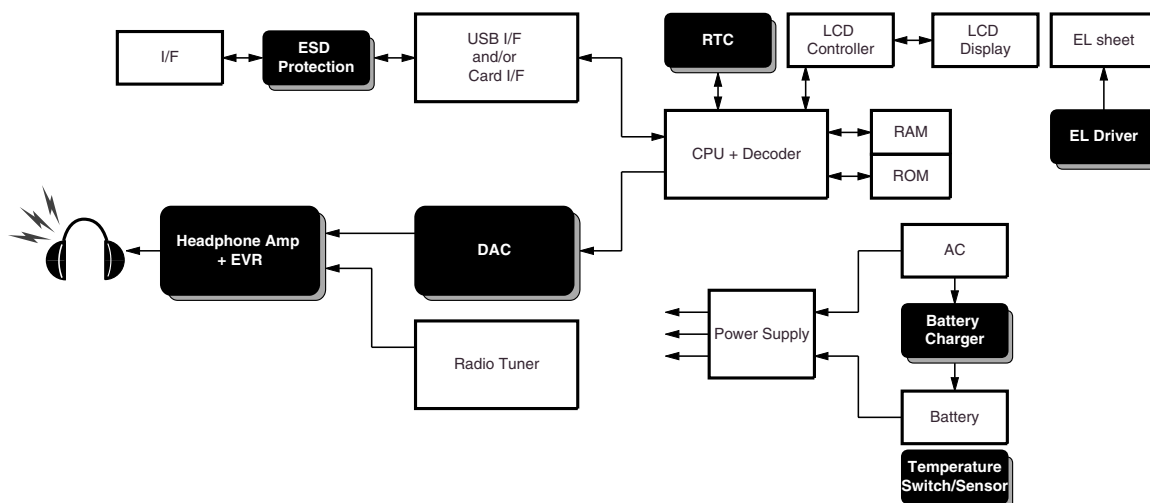

## NPC Products

RTC			
NR8576 series	Crystal oscillator element built-in for adjustment free use, serial interface, 32.768kHz and 1Hz output selectable.	2.5 to 5.5V	SOP14/SOP18
SM8577B	3-wire serial interface, 32.768kHz and 1Hz output selectable.	2.5 to 5.5V	SOP8
SM8578B	3-wire serial interface, Date, day, hour, and minute-counter presettable alarm and timer interrupt functions, Low current consumption.	1.6 to 5.5V	VSOP8
SM8580A	Built-in temperature sensor, High-speed bus 4-bit parallel interface, Date, day, hour, minute, and second-counter presettable alarm interrupt function, Low current consumption.	1.6 to 5.5V	SSOP24
DAC			
SM5879A	D/A converter with built-in digital bass boost and 3rd-order post-analog lowpass filter, 384fs system clock.	2.7 to 3.3V	VSOP24
Headphone Amp + EVR			
SM6453A	Headphone amplifiers with built-in electronic volume control, Bass boost function, Beep sound input.	1.9 to 3.6V	QFN32
EVR			
SM6451B	Audio variable volume IC, Stereo inputs and outputs, Attenuation function, Mute function, 3-wire serial data control.	2.4 to 3.6V	VSOP16
ESD Protection			
SM6503A	± 12kV (contact discharge) ESD protection, 5 circuits integrated into one package.	—	SOT23-6/SON6

## NPC Application Guide

Temperature Sensor/Switch			
SM6610 series	Temperature sensor IC, Analog output, Linearity: $\pm 0.5\%$ .	4.0 to 5.5V 2.4 to 5.5V	SC82AB/VSP4
SM6611 series	Temperature switch IC, 6 output switching temperatures and 2 output configurations are available.	2.4 to 10.0V	SOT23-6W
Battery Charger			
SM6780A	Ni-MH/Ni-Cd battery charger IC, First charge termination by $-\Delta V$ or $\Delta T/\Delta t$ , 3 selectable charge times, Charge condition LED indicator output.	4.0 to 5.5V	SOP8
SM6781B	Ni-MH/Ni-Cd battery charger IC, First charge termination by $-\Delta V$ , 3 selectable charge times, Charge condition LED indicator output.	4.0 to 5.5V	VSOP8
EL Driver			
SM8141A/B	Capable driving EL size: $50\text{cm}^2$ , EL drive frequency and coil drive frequency independently controllable (A version), Enable function (B version).	2.0 to 5.5V	VSOP8
SM8142A/B	Capable driving EL size: $30\text{cm}^2$ , EL drive frequency and coil drive frequency independently controllable (A version), Enable function (B version).	1.6 to 5.5V	VSOP8/SON8
SM8145A	Capable driving EL size: $30\text{cm}^2$ , 2 separate (2 colors) EL display drivers, 2-display simultaneous driver operation, Adjustable luminance and current consumption in each mode.	1.6 to 5.5V	QFN20
Power Supply			
SM6702 series	PFM step-up DC/DC converter, 2.2 to 3.3V output voltage available in 0.1V step, Low power consumption, High efficiency: 85%, Low ripple voltage.	—	SOT23-3/SOT89-3

NIPPON PRECISION CIRCUITS INC. reserves the right to make changes to the products described in this data sheet in order to improve the design or performance and to supply the best possible products. Nippon Precision Circuits Inc. assumes no responsibility for the use of any circuits shown in this data sheet, conveys no license under any patent or other rights, and makes no claim that the circuits are free from patent infringement. Applications for any devices shown in this data sheet are for illustration only and Nippon Precision Circuits Inc. makes no claim or warranty that such applications will be suitable for the use specified without further testing or modification. The products described in this data sheet are not intended to use for the apparatus which influence human lives due to the failure or malfunction of the products. Customers are requested to comply with applicable laws and regulations in effect now and hereinafter, including compliance with export controls on the distribution or dissemination of the products. Customers shall not export, directly or indirectly, any products without first obtaining required licenses and approvals from appropriate government agencies.

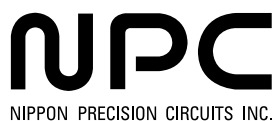

NIPPON PRECISION CIRCUITS INC.

4-3, Fukuzumi 2-chome, Koto-ku,  
Tokyo 135-8430, Japan  
Telephone: +81-3-3642-6661  
Facsimile: +81-3-3642-6698  
<http://www.npc.co.jp/>  
Email: sales@npc.co.jp

NK0104AE 2001.10